



STORMWATER QUALITY HANDBOOKS

PPDG

PROJECT PLANNING AND DESIGN GUIDE

JULY 2017 | CTSW-RT-17-314.24.1 (Updated APRIL 2019)



CONSTRUCTION

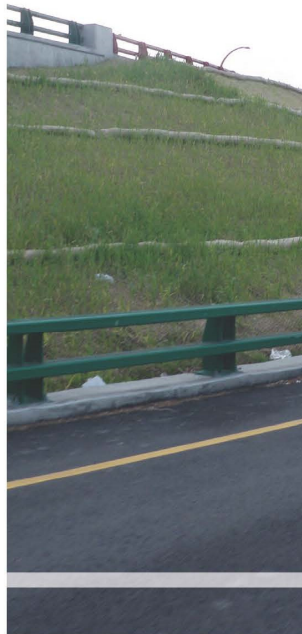

DESIGN POLLUTION
PREVENTION



TREATMENT



MAINTENANCE

HANDBOOKS

Project Planning and Design Guide (PPDG)

Construction Site Best Management Practice (BMPs) Manual

Stormwater Pollution Prevention Plan (SWPPP) and Water Pollution Control Program (WPCP) Preparation Manual

Caltrans

Stormwater Quality Handbook: Project Planning and Design Guide

Distributed by
HQ Office of Hydraulics and Stormwater Design

July 2017 (Updated April 2019)

The April 2019 updated text has a border line indicating changes.

**For individuals with sensory disability, this document is available
in Braille, large print, on audiocassette, or compact disk.**

To obtain a copy in one of these alternate formats, please contact:

Stormwater Liaison, Caltrans Division of Environmental Analysis

MS 27, P.O. Box 942874, Sacramento, CA 94274-0001

(916) 653-8896 Voice or dial 711 to use a relay service.

TABLE OF CONTENTS

LIST OF FIGURES.....	X
LIST OF TABLES.....	XI
1 INTRODUCTION.....	1-1
1.1 Overview.....	1-1
1.2 BMP Selection and Project Development Process.....	1-2
1.3 Stormwater Guidance Documents.....	1-3
1.4 Regulations and Permits.....	1-4
1.4.1 Federal Regulations.....	1-4
1.4.2 Caltrans NPDES Statewide Stormwater Permit.....	1-4
1.4.2.1 Hydromodification/Rapid Stability Assessment (RSA).....	1-4
1.4.3 Caltrans Statewide Stormwater Management Plan (SWMP).....	1-5
1.4.4 Construction General Permit (CGP).....	1-5
1.4.4.1 Rainfall Erosivity Waiver.....	1-6
1.4.5 Stormwater Pollution Prevention Plan (SWPPP).....	1-6
1.4.6 Water Pollution Control Program (WPCP).....	1-6
1.4.7 Additional Requirements.....	1-6
1.5 Permit and SWMP Implementation.....	1-7
1.5.1 District Work Plans (DWP).....	1-7
2 DESIGN PROGRAM RESPONSIBILITIES.....	2-1
2.1 Introduction to Design Program Responsibilities.....	2-1
2.2 Management.....	2-1
2.3 Stormwater Advisory Teams (SWATs).....	2-1
2.4 Stormwater Coordinators.....	2-2
2.5 Responsibilities as They Relate to Encroachment Permits and Third-Party Activities.....	2-2
2.6 Responsibilities for Coordination with Municipal Stormwater Permittees (Local Agencies).....	2-3
2.7 Consultation with Regional Water Quality Control Boards (RWQCBs) and Local Regulatory Agencies.....	2-3
2.8 Staff and Functional Units.....	2-3
2.8.1 Staff.....	2-3
2.8.2 District Functional Units.....	2-5
3 BEST MANAGEMENT PRACTICE OVERVIEW.....	3-1
3.1 Introduction.....	3-1
3.2 Identification of Water Quality Requirements for Project Planning Purposes.....	3-1
3.2.1 State Water Resources Control Board (SWRCB) and Regional Water Quality Control Boards (RWQCBs).....	3-1
3.2.2 Resources for Identifying Pollution Control Requirements.....	3-4
3.2.2.1 Regional Water Quality Control Board Basin Plans.....	3-4
3.2.2.2 Total Maximum Daily Loads (TMDLs) and 303(d) Lists.....	3-4
3.2.2.3 401 Certifications and Waste Discharge Requirements (WDRs).....	3-5

TABLE OF CONTENTS

3.2.3	Stormwater Documents.....	3-5
3.2.4	Targeted Design Constituents (TDC).....	3-5
3.2.5	Pollutants of Concern	3-6
3.2.5.1	Solids (Suspended and Dissolved).....	3-6
3.2.5.2	Nutrients	3-8
3.2.5.3	Pesticides (incl. Herbicides).....	3-8
3.2.5.4	Metals (Particulate and Dissolved)	3-8
3.2.5.5	Pathogens and Bacteria.....	3-9
3.2.5.6	Litter/Trash	3-9
3.2.5.7	Biochemical Oxygen Demand.....	3-9
3.2.5.8	Turbidity	3-10
3.2.5.9	Temperature	3-10
3.2.5.10	Mercury	3-10
3.2.5.11	Polychlorinated Biphenyl (PCB)	3-11
3.3	BEST MANAGEMENT PRACTICES	3-11
3.3.1	Design Pollution Prevention (DPP) Best Management Practices.....	3-13
3.3.2	Treatment Best Management Practices.....	3-13
3.3.3	Construction Site Best Management Practices	3-14
3.3.4	Maintenance Best Management Practices	3-15
4	TREATMENT CONSIDERATION	4-1
4.1	Introduction	4-1
4.2	Treatment Objectives.....	4-1
4.3	Project Evaluation Process.....	4-1
4.4	Treatment Areas.....	4-5
4.4.1	Additional Treated Area (ATA).....	4-6
4.4.2	Treatment Area Example	4-7
4.5	Alternative Compliance.....	4-10
4.6	TMDL Watersheds and Compliance Units (CUs).....	4-11
5	PERMANENT BMP STRATEGY	5-1
5.1	Introduction and Objectives	5-1
5.2	Site Design and Design Pollution Prevention (DPP) Best Management Practices	5-1
5.2.1	Evaluation of Design Pollution Prevention (DPP) Infiltration Areas for Treatment	5-4
5.3	Treatment Best Management Practices Design Consideration	5-6
5.3.1	Site-Specific Determination of Feasibility.....	5-8
5.3.2	Treatment BMP Use and Placement Considerations	5-8
5.3.3	Determining Water Quality Volume (WQV) and Water Quality Flows (WQF)	5-9
5.3.3.1	Volumetric Runoff Coefficient for Calculating Water Quality Volume ...	5-10
5.3.3.2	Water Quality Volume and Water Quality Flow Combined Mechanism for Treatment	5-11
5.3.3.3	Water Quality Flows (WQF).....	5-11
5.3.4	Selection Prioritization of Treatment BMPs.....	5-13
5.3.5	Incorporation of Non-Approved Treatment BMPs	5-14



TABLE OF CONTENTS

5.4 Documenting Treatment.....	5-14
6 STORMWATER DATA REPORT DEVELOPMENT PROCESS	6-1
6.1 Introduction	6-1
6.2 Project Types, Scopes, and Magnitude	6-1
6.3 How the SWDR Fits into the Project Delivery Process	6-1
6.3.1 Project Initiation Document (PID).....	6-1
6.3.2 Project Approval/Environmental Document (PA/ED)	6-2
6.3.3 Plans, Specifications, and Estimate (PS&E).....	6-2
6.4 Stormwater Data Report (SWDR).....	6-2
6.4.1 Cover Page.....	6-3
6.4.2 Section 1 - Project Description.....	6-3
6.4.3 Section 2 - Site Data and Stormwater Design Issues.....	6-4
6.4.3.1 Checklists SW-1, SW-2, and SW-3.....	6-4
6.4.3.2 Discussion of Pertinent Data.....	6-4
6.4.4 Section 3 -Construction Site BMPs.....	6-7
6.4.4.1 Construction Concurrence Documentation	6-9
6.4.4.2 CGP Coverage and Risk Level Determination	6-9
6.4.4.3 Stormwater Pollution Prevention Plan (SWPPP) and Water Pollution Control Program (WPCP).....	6-10
6.4.4.4 Active Treatment Systems (ATS).....	6-10
6.4.5 Section 4 - Maintenance BMPs.....	6-11
6.4.6 Section 5 - Other Water Quality Requirements and Agreements.....	6-11
6.4.7 Section 6 - Permanent BMPs.....	6-12
6.4.7.1 Introduction	6-12
6.4.7.2 Design Pollution Prevention BMP Strategy.....	6-13
6.4.7.3 Treatment BMP Strategy.....	6-15
6.4.7.4 Validation of Final Soil Stabilization.....	6-17
6.4.7.5 Compliance with Model Water Efficient Landscape Ordinance (MWELO).6- 18	
6.4.8 Required Attachments.....	6-18
6.4.8.1 Vicinity Map of the Project Area.....	6-19
6.4.8.2 Stormwater Data Report (SWDR) Attachment for Stormwater Multiple	

TABLE OF CONTENTS

Application Report Tracking System (SMARTS) Input.....	6-19
6.4.9 Cost Estimating for BMPs.....	6-19
6.4.9.1 Project Planning Cost Estimates (PPCE) (PID and PA/ED).....	6-19
6.4.9.2 Preliminary Engineer’s Cost Estimates (PECE) (PS&E).....	6-20
6.4.9.3 Incorporating Stormwater BMPs into Projects.....	6-20
6.5 Resident Engineer’s (RE) File.....	6-21
6.6 SWDR Summary Spreadsheets.....	6-21
APPENDIX A: APPROVED DESIGN POLLUTION PREVENTION BMPS AND CHECKLISTS.....	A
A.1 Required Minimum Design Elements for Stormwater Control.....	1
A.2 Consideration of Downstream Effects Related to Potentially Increased Flow.....	1
A.3 Preservation of Existing Vegetation.....	2
A.4 Concentrated Flow Conveyance Systems.....	3
A.5 Slope/Surface Protection Systems.....	7
A.6 Design Pollution Prevention (DPP) BMP Checklists.....	13
APPENDIX B: APPROVED TREATMENT BMPS AND CHECKLISTS.....	B
B.1 Treatment BMPs.....	1
B.1.1 Infiltration Requirements and Tools.....	1
B.1.2 Targeted Design Constituent (TDC).....	1
B.1.3 Incorporation of Existing Features as Treatment BMPs.....	2
B.1.4 Interaction with other Caltrans Functional Units.....	2
B.1.5 Hydraulic Issues Related to Treatment BMPs.....	3
B.1.5.1 Treatment BMPs as a Component of the Drainage System.....	3
B.1.5.2 Use of Peak Flow Attenuation Devices as WQV-Based Treatment BMPs.....	4
B.1.6 Caltrans Treatment BMP Website.....	4
B.2 DPP Infiltration Areas.....	5
B.2.1 Description.....	5
B.2.2 Appropriate Applications and Siting Criteria.....	6
B.2.3 Factors Affecting Preliminary Design.....	6
B.2.4 Checklist.....	7
B.3 Infiltration Devices.....	9
B.3.1 Description.....	9
B.3.2 Appropriate Applications and Siting Criteria.....	11
B.3.3 Factors Affecting Preliminary Design.....	12
B.3.4 Checklist.....	13
B.4 Biofiltration Strips and Swales (Vegetated Treatment Systems).....	16
B.4.1 Description.....	16
B.4.2 Appropriate Applications and Siting Criteria.....	16
B.4.3 Factors Affecting Design.....	17
B.4.4 Checklist.....	17
B.5 Detention Devices.....	20
B.5.1 Description.....	20
B.5.2 Appropriate Applications and Siting Criteria.....	20



TABLE OF CONTENTS

B.5.3 Factors Affecting Preliminary Design.....	21
B.5.4 Checklist.....	21
B.6 Traction Sand Traps (TST)	24
B.6.1 Description	24
B.6.2 Appropriate Applications and Siting Constraints	25
B.6.3 Factors Affecting Preliminary Design.....	25
B.6.4 Checklist.....	25
B.7 Dry Weather Flow Diversion	28
B.7.1 Description	28
B.7.2 Appropriate Applications and Siting Criteria	28
B.7.3 Factors Affecting Preliminary Design.....	29
B.7.4 Checklist.....	29
B.8 Gross Solids Removal Devices (GSRDs): Linear Radial and Inclined Screen	31
B.8.1 Description	31
B.8.2 Appropriate Applications and Siting Criteria	35
B.8.3 Factors Affecting Preliminary Design.....	36
B.8.4 Checklist.....	36
B.9 Media Filters.....	39
B.9.1 Description	39
B.9.2 Appropriate Applications and Siting Criteria	40
B.9.3 Factors Affecting Preliminary Design.....	45
B.9.4 Checklist.....	45
B.10 Multi-Chamber Treatment Train (MCTT)	50
B.11 Wet Basin	50
B.12 Pervious Pavement.....	50
B.13 Open Graded Friction Course.....	51
B.13.1 Description.....	51
B.13.2 Appropriate Applications and Siting Criteria	51
B.14 Bioretention.....	52
B.14.1 Description	52
B.14.2 Appropriate Applications, Siting, and Design Criteria.....	53
B.14.3 Factors Affecting Preliminary Design	53
APPENDIX C: CONSTRUCTION SITE BMPS AND CHECKLISTS	C
C.1 Construction Site Best Management Practices (BMPs)	1
C.1.1 Temporary Soil Stabilization BMPs	3
c.1.1.1 Scheduling.....	5
C.1.1.2 Preservation of Existing Vegetation.....	5
C.1.1.3 Hydraulic Mulch.....	6
C.1.1.4 Hydroseed.....	6
C.1.1.5 Soil Binder.....	6
C.1.1.6 Straw Mulch.....	6
C.1.1.7 Temporary Cover and Rolled Erosion Control Products (RECP)	7



TABLE OF CONTENTS

C.1.1.8	Wood Mulch.....	7
C.1.1.9	Earth Dikes/Drainage Swales and Lined Ditches	7
C.1.1.10	Outlet Protection/Velocity Dissipation Devices	7
C.1.1.11	Slope Drains	8
C.1.1.12	Streambank Stabilization	8
C.1.2	Sediment Control Practices.....	8
C.1.2.1	Silt Fence	9
C.1.2.2	Sediment/Desilting Basin.....	9
C.1.2.3	Sediment Trap/Curb Cutback.....	9
C.1.2.4	Check Dam	9
C.1.2.5	Fiber Rolls/Large Sediment Barrier	9
C.1.2.6	Gravel Bag/Earthen Berm	10
C.1.2.7	Street Sweeping and Vacuuming	10
C.1.2.8	Sand Bag Barrier	10
C.1.2.9	Straw Bale Barrier	10
C.1.2.10	Drainage Inlet Protection	10
C.1.2.11	Compost Sock.....	11
C.1.2.12	Flexible Sediment Barrier	11
C.1.3	Tracking Control Practices.....	11
C.1.3.1	Temporary Construction Entrance.....	11
C.1.3.2	Temporary Construction Roadway	11
C.1.3.3	Entrance/Outlet Tire Wash	12
C.1.3.4	Street Sweeping and Vacuuming	12
C.1.4	Wind Erosion Control	12
C.1.5	Non-Stormwater Management BMPs	12
C.1.5.1	Water Conservation Practices	13
C.1.5.2	Dewatering Operations	13
C.1.5.3	Paving, Sealing, Sawcutting, and Grinding Operations.....	13
C.1.5.4	Temporary Stream Crossing	13
C.1.5.5	Clear Water Diversion	13
C.1.5.6	Illegal Connection/Illicit Discharge Detection and Reporting.....	13
C.1.5.7	Potable Water/Irrigation	13
C.1.5.8	Vehicle and Equipment Cleaning	14
C.1.5.9	Vehicle and Equipment Fueling.....	14
C.1.5.10	Vehicle and Equipment Maintenance.....	14
C.1.5.11	Pile Driving Operations.....	14
C.1.5.12	Concrete Curing.....	14
C.1.5.13	Material and Equipment Use Over Water	14
C.1.5.14	Concrete Finishing.....	14
C.1.5.15	Structure Demolition/Removal Over or Adjacent to Water.....	14
C.1.6	Waste Management and Materials Pollution Control.....	15
C.1.6.1	Material Delivery and Storage	15
C.1.6.2	Material Use.....	15



TABLE OF CONTENTS

C.1.6.3	Stockpile Management.....	15
C.1.6.4	Spill Prevention and Control.....	15
C.1.6.5	Solid Waste Management.....	16
C.1.6.6	Hazardous Waste Management.....	16
C.1.6.7	Contaminated Soil Management.....	16
C.1.6.8	Concrete Waste Management.....	16
C.1.6.9	Sanitary/Septic Waste Management.....	16
C.1.6.10	Liquid Waste Management.....	17
C.2	Clear Water Diversion.....	17
C.2.1	Introduction.....	17
C.2.1.1	Overview.....	17
C.2.1.2	Caltrans Project Delivery Staff Coordination.....	17
C.2.1.3	CGP/ NPDES Compliance SWPPP/WPCP Documentation.....	18
C.2.1.4	Appropriate Uses.....	18
C.2.2	Factors Affecting Preliminary Design.....	18
C.2.2.1	Design Considerations.....	18
C.2.2.2	Hydrology Methods for Sizing.....	19
C.2.2.3	Limitations.....	19
C.2.2.4	Standards and Specifications.....	19
C.3	Active Treatment Systems.....	20
C.3.1	Introduction.....	20
C.3.1.1	Overview.....	20
C.3.1.2	Construction General Permit.....	21
C.3.2	ATS Selection Criteria.....	21
C.3.2.1	Determine Risk.....	21
C.3.2.2	Potential Storage Area and Peak Stormwater Flow.....	21
C.3.2.3	Soil Type.....	22
C.3.2.4	Settling Velocity and Required Settling Area.....	22
C.3.2.5	Determine Appropriate Device.....	22
C.3.3	Factors Affecting Preliminary Design.....	24
C.3.3.1	Pollution Prevention/Sediment Mitigation.....	24
C.3.3.2	Collection System/Discharge Piping.....	24
C.3.3.3	Storage/Pre-Sedimentation.....	24
C.3.3.4	Treatment Components.....	24
C.3.3.4.1	Coagulation /Flocculation.....	25
C.3.3.4.2	pH Adjustment.....	26
C.3.4	Active Treatment System Sizing.....	28
C.3.4.1	Construction Area.....	29
C.3.4.1.1	Flowrate.....	29
C.3.4.1.2	Sedimentation Residence Time.....	29
C.4	Construction Site (CS) BMP Checklists.....	29

APPENDIX D: RELEVANT STORMWATER DOCUMENTS, WEBSITES, AND PROCESS SUMMARY FORMSD

TABLE OF CONTENTS

APPENDIX E: STORMWATER DATA REPORT AND CHECKLISTS.....	E
APPENDIX F: COST ESTIMATES	F
F.1 Introduction	1
F.1.1 Policy and Guidance	1
F.1.2 Construction Duration.....	1
F.2 Standard Specifications, Contract Plans, and Special Provisions	1
F.3 Estimating Methods.....	1
F.3.1 Project Initiation Cost Estimate Method	2
F.3.2 Project Design Cost Estimate Method	4
F.3.3 Water Pollution Control Contract Bid Items.....	6
F.3.3.1 Supplemental Costs	9
F.3.3.2 Department Furnished Materials	10
F.4 Temporary Active Treatment System (Contract Bid Item: 130800)	11
F.4.1 Construction Costs.....	11
F.4.2 Operational Costs.....	12
F.5 Temporary Stream Diversion System (Contract Bid Item: To Be Determined)	13
F.6 Water Quality Monitoring.....	14
APPENDIX G: ABBREVIATIONS, ACRONYMS, AND DEFINITION OF TERMS.....	G
G.1 Abbreviations.....	1
G.2 Acronyms	2
G.3 Definition of Terms.....	9



TABLE OF CONTENTS

List of Figures

Figure 1-1. Project Development Process Summary	1-3
Figure 3-1. Map of California with RWQCB and District Boundaries	3-3
Figure 4-1. Project Evaluation Process for Consideration of Permanent Treatment BMPs.....	4-2
Figure 4-2. Basic Roadway Pavement Layers	4-5
Figure 5-1. Decision Process for Selecting Design Pollution Prevention BMPs	5-3
Figure 5-2. Highway Widening, Treatment Not Required	5-5
Figure 5-3. Highway Widening, Treatment Required	5-7
Figure A-1. Ditches, Berms, Dikes, and Swales	4
Figure A-2. Flared Culvert End Section	6
Figure A-3. Outlet Protection/Velocity Dissipation Device	7
Figure A-4. Slope Rounding, Stepping, Terracing, and Contouring.....	10
Figure A-4. Slope Rounding, Stepping, Terracing, and Contouring (Continued)	11
Figure B-1. Schematic of a DPP Infiltration Area	6
Figure B-2. Schematic of an Infiltration Basin	10
Figure B-3. Schematic of an Infiltration Trench	11
Figure B-4. Schematic of Linear Radial Device.....	32
Figure B-5. Schematic of Linear Radial Device (HV).....	33
Figure B-6. Linear Radial Device (partially full).....	34
Figure B-7. Inclined Screen Device.....	35
Figure B-8. Caltrans Pilot Media Filters (Austin Sand Filter [left], Delaware Sand Filter [right]) ...	40
Figure B-9. Schematic of an Austin Sand Filter - Full Sedimentation (Earthen Type)	41
Figure B-10. Schematic of an Austin Sand Filter - Partial Sedimentation (Earthen Type)	42
Figure B-11. Schematic of a Delaware Sand Filter.....	43
Figure B-11. Schematic of a Delaware Sand Filter (Continued).....	44
Figure C-1. Active Treatment System Decision Tree.....	23
Figure C-2. Potential Treatment Schematic	25
Figure C-3. Sedimentation Tank (Devil's Slide).....	27
Figure C-4. Bag/Cartridge Filters (Devil's Slide)	28

TABLE OF CONTENTS

List of Tables

Table 3-1. Pollutants of Concern from Typical Highway Runoff and Applicable Treatment BMPs...	7
Table 3-2. BMP Categories, Descriptions and Responsible Divisions.....	3-12
Table 3-3. Design Pollution Prevention (DPP) BMPs	3-13
Table 3-4. Approved Treatment BMPs.....	3-14
Table 3-5. Approved Construction Site BMP Categories	3-14
Table 4-1. Excluded Impervious Areas	4-5
Table 5-1. Design Pollution Prevention BMPs	5-2
Table 5-2. Volumetric Runoff Coefficients	5-11
Table 5-3. Flow-Based Runoff Coefficients	5-12
Table B-1. Summary of DPP Infiltration Areas Siting and Design Criteria.....	6
Table B-2. Summary of Infiltration Device Siting and Design Criteria	12
Table B-3. Summary of Biofiltration Strips and Swales Siting and Design Factors.....	17
Table B-4. Summary of Detention Device Siting and Design Criteria.....	21
Table B-5. Summary of Traction Sand Trap Siting and Design Criteria.....	25
Table B-6. Summary of Dry Weather Flow Diversion Siting and Design Criteria	29
Table B-7. Summary of Gross Solids Removal Devices (Linear Radial and Inclined Screen).....	36
Table B-8. Summary of Media Device Siting and Design Criteria.....	45
Table B-9. Summary of Bioretention Siting and Design Criteria.....	53
Table C-1. Temporary Soil Stabilization Criteria Matrix.....	4
Table C-2. Temporary Soil Stabilization Criteria Matrix (continued).....	5
Table C-3. Potential ATS Components.....	25
Table C-4. Potential ATS Chemicals.....	26
Table C-5. Suggested pH Adjustment Chemicals	26
Table D-1. Relevant Stormwater Documents and Purpose	1
Table D-2. Stormwater Related Websites	2
Table D-3. Summary of Stormwater Activities for Project Initiation Document (PID).....	3
Table D-4. Summary of Stormwater Activities for Project Approval/Environmental Document (PA/ED).....	5
Table D-5. Summary of Stormwater Activities for Plans, Specifications & Estimates (PS&E).....	7
Table D-6. Summary of Stormwater Activities During Construction	9
Table E-1. Overall Project Treatment Summary Table ¹	8
Table E-2. Individual Treatment BMP Summary Table ¹	24
Table F-1. Estimating Methods Available During the Project Development Processes	2
Table F-2. Percentage of Extra Cost to Project Due to Construction Site BMPs.....	3
Table F-3. Installed Costs of Bmps ¹	5
Table F-4. Construction Site Water Pollution Control	6
Table F-5. Construction Cost Estimate Per Year ¹	11
ASBS Locations.....	10

THIS PAGE INTENTIONALLY LEFT BLANK.

1 Introduction

1.1 Overview

This Project Planning and Design Guide (PPDG) provides guidance on the process and procedures for evaluating project scope and site conditions to determine the need for and feasibility of incorporating Best Management Practices (BMPs) into projects within the Caltrans right-of-way. This PPDG provides design guidance for incorporating those stormwater quality controls into projects during the planning and project development process. This document supersedes prior stormwater design guidance manuals and has been prepared in support of the *Statewide Stormwater Management Plan* (SWMP). The PPDG addresses key regulatory, policy, and technical requirements by providing direction on the procedures to incorporate stormwater BMPs into the design of all Caltrans projects. In addition to the direction provided in this PPDG, the user is expected to apply their own engineering knowledge and judgment when evaluating and designing stormwater BMPs.

The key objective of this PPDG is to provide the overall process for selecting and designing BMPs and incorporating those BMPs into the appropriate documents at each project delivery phase (Project Initiation Document (PID), the Project Approval/Environmental Document (PA/ED), and the Plans, Specifications and Estimates (PS&E)). The planning and design approach described herein has been developed to fit within the appropriate Work Breakdown Structure (WBS) codes and activities identified in the *Caltrans Project Development Procedures Manual* (PDPM) and the *Guide to Project Delivery Workplan Standards*. These documents can be found on the web at the following sites:

<http://www.dot.ca.gov/hq/oppd/pdpm/pdpmn.htm>

<http://www.dot.ca.gov/hq/projmgmt/guidance.htm>

Also, the Stormwater Data Report (SWDR), which summarizes the stormwater quality issues of a project, and its corresponding checklists, are described in this manual. These documents are provided in the appendices, and are used for guidance in evaluating BMPs considered during the PID, PA/ED, and PS&E processes. This PPDG is organized as follows:

Section 1 – Introduction: Provides an overview of the BMP selection and project development process, the history of the existing stormwater guidance documents, regulations and permits, SWMP implementation, design compliance monitoring and annual reporting requirements.

Section 2 – Design Program Responsibilities: Identifies specific staff responsibilities.

Section 3 – Best Management Practice Overview: Provides background information and guidance necessary for the appropriate selection of permanent and temporary BMPs.

Section 4 – Treatment Consideration: Provides guidance for evaluating whether a project must consider incorporating Treatment BMPs based upon project-specific criteria. Defines treatment areas and provides guidance for determining the required amount of area to be treated (i.e. Post Construction Treatment Area).

Section 5 – Permanent BMP Strategy: Provides the approach to developing a permanent treatment strategy for projects through the use of approved Design Pollution Prevention (DPP) BMPs and, when required, Treatment BMPs. For projects that are required to implement Treatment BMPs, this section describes the Treatment BMP prioritization process and methods to calculate water quality volume and flow.

Section 6 – Stormwater Data Report Development Process: Describes the overall PID, PA/ED, and PS&E process, including the identification and evaluation of stormwater quality issues, and development of the final design of the project, permanent BMPs, and temporary BMP strategy. Also describes the process of preparing the SWDR throughout the project development process.

Appendix A – Approved Design Pollution Prevention BMPs. Describes the DPP BMPs that are considered during all phases of the project development process. These BMPs are then incorporated into the design of new facilities and the reconstruction, rehabilitation, or expansion of existing facilities.

Appendix B – Approved Treatment BMPs. Describes the Treatment BMPs that are considered during all phases of the project development process.

Appendix C – Construction Site BMPs. Describes and lists the Construction Site BMPs that should be considered for use during construction activities to reduce pollutants in stormwater discharges throughout construction.

Appendix D – Relevant Stormwater Information. Provides a summary of the relevant stormwater related documents and their purpose, and the websites that are referenced in this document.

Appendix E – Stormwater Data Report. Provides the SWDR template and some of the attachments to be used for projects throughout the PID, PA/ED, and the PS&E processes. The SWDR documents decisions made throughout the planning and project development processes regarding stormwater quality.

Appendix F – Cost Estimates. Provides guidance on how to estimate the cost of stormwater items into the overall project cost.

Appendix G – Abbreviations, Acronyms, Definition of Terms and References.

1.2 BMP Selection and Project Development Process

The overall process to select BMPs as part of each of the project phases, PID, PA/ED, and PS&E, is shown in Figure 1-1. This figure presents the procedure for BMP implementation throughout the project development process from securing funds in the PID, to selecting the preferred BMP alternative in the PA/ED and preparing detailed design in the PS&E. Each phase of the project is individually described in Section 6. Implementation activities generally follow the procedures presented in the PDPM.

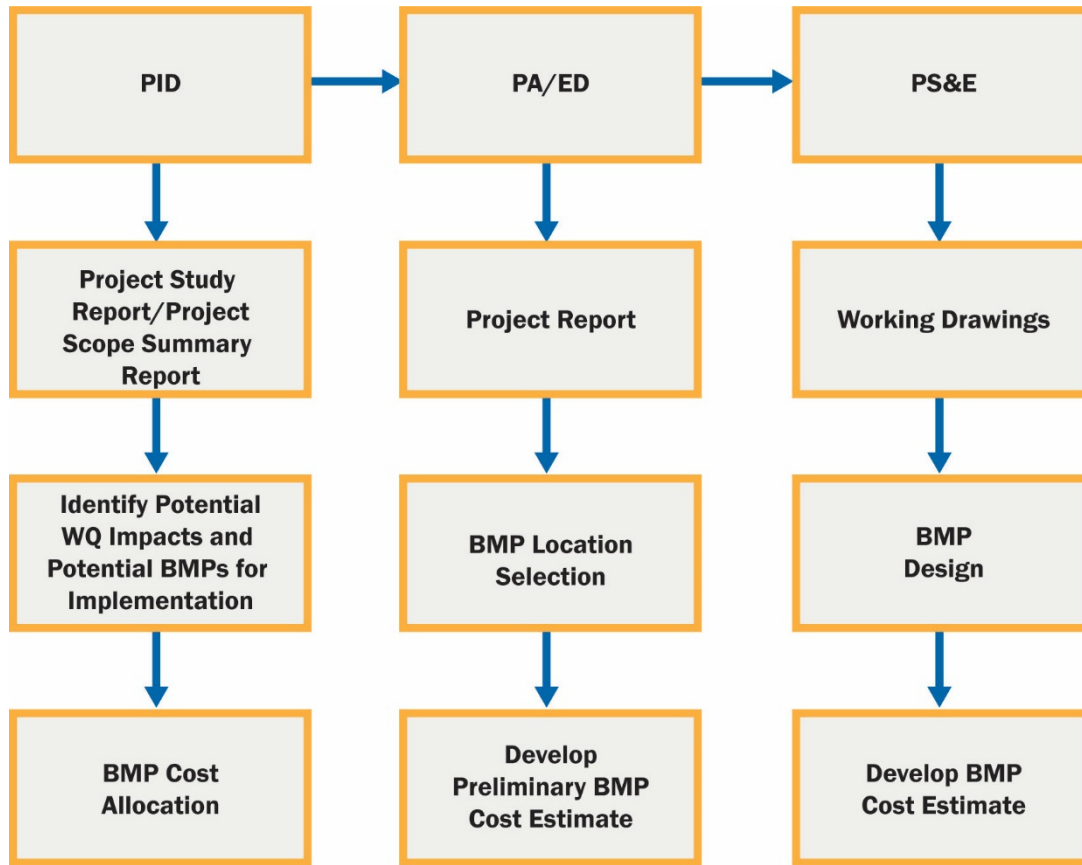

Figure 1-1. Project Development Process Summary

It is important to note that this document provides minimum guidelines and that additional requirements may have to be incorporated on a project-by-project basis to comply with special requirements from a Regional Water Quality Control Board (RWQCB), specific district guidelines, environmental laws, or as a result of other studies. Other stormwater quality elements that Project Engineers (PE) may have to consider are included in each District's Work Plan (DWP).

Special site conditions may warrant variations from the guidance provided herein. The PE is responsible for recognizing site conditions that warrant variations in procedures, and for securing appropriate approvals for these variations before proceeding with design.

1.3 Stormwater Guidance Documents

In order to meet the demands of the stormwater management process in regards to controlling pollutant discharges and meeting permit requirements, several documents have been developed. Appendix D provides a list and a brief summary of these documents and their purposes.

1.4 Regulations and Permits

1.4.1 Federal Regulations

Federal regulations for controlling discharges of pollutants from Municipal Separate Storm Sewer Systems (MS4s), construction sites, and industrial activities were incorporated into the National Pollutant Discharge Elimination System (NPDES) permit process by the 1987 amendments to the Clean Water Act (CWA) and by the subsequent 1990 promulgation of federal stormwater regulations issued by the U.S. Environmental Protection Agency (EPA). The EPA regulations require municipal, construction and industrial stormwater discharges to comply with an NPDES permit. In California, the EPA delegated its authority to issue NPDES permits to the State Water Resources Control Board (SWRCB).

1.4.2 Caltrans NPDES Statewide Stormwater Permit

The SWRCB issued an NPDES Statewide Stormwater Permit (Caltrans Permit) to Caltrans, to regulate stormwater and non-stormwater discharges from Caltrans properties and facilities, and discharges associated with operation and maintenance of the State highway system. The Caltrans Permit contains three basic requirements:

1. Caltrans must comply with the requirements of the *Construction General Permit* (CGP) described in Section 1.4.4;
2. Caltrans must implement a year-round program in all parts of the State to effectively control stormwater and non-stormwater discharges; and
3. Caltrans stormwater discharges must meet water quality standards through implementation of permanent and temporary BMPs and other measures.

All projects within the Department's right-of-way (RW) that completed the PID phase after July 1, 2013 must comply with the new post construction stormwater treatment requirements and the hydromodification requirements described herein.

The Caltrans Permit regulates stormwater discharges from Caltrans RW during and after construction, as well as from existing facilities and activities. The Caltrans Permit gives RWQCBs the option to specify additional requirements they may consider necessary to meet water quality standards. Copies of the Caltrans Permit can be downloaded from the SWRCB web site, at:

http://www.waterboards.ca.gov/water_issues/programs/stormwater/caltrans.shtml.

Discharges from Caltrans RW that are not composed entirely of stormwater are prohibited unless the non-stormwater discharges are from a source authorized under the SWMP. Therefore, appropriate BMPs must be installed to remove pollutants to the Maximum Extent Practicable (MEP). The permit language is "Discharge of material other than storm water, or discharge that is not composed entirely of storm water, to waters of the United States or another permitted MS4 is prohibited, except as conditionally exempted under... [the Caltrans Permit] or authorized by a separate NPDES permit."

1.4.2.1 Hydromodification/Rapid Stability Assessment (RSA)

Modifications of the terrain associated with development, such as the construction of roads, parking lots, and buildings, change the local hydraulics by shifting more stormwater to runoff and less to

infiltrate into the soil. This change in watershed cover types and surface soil conditions is called hydromodification, and is often associated with accelerated erosion and deposition in stream channels that receive runoff from developed areas. The Caltrans Permit mandates that a rapid stability assessment (RSA) be conducted during planning and design for all projects that will include 1 acre or more of net new impervious (NNI) and for any new impervious portion of the project that drains to a stream crossing located within the project limits. Additionally, the stream crossing within the project must be defined as a Water of the United States. Projects that meet these criteria should consult Section 2 of the *Caltrans Hydromodification Requirements Guidance* for information related to conducting an RSA. If the project does not meet all of the criteria, then an RSA is not required. For projects that do not have an RSA, evaluating and implementing DPP and Treatment BMPs, as described in this PPDG, will meet the overall Hydromodification requirement.

The *Caltrans Hydromodification Requirements Guidance* describes how to perform an RSA and describes higher level analysis. This document can be found on the web at the following site:

<http://www.dot.ca.gov/hq/oppd/stormwtr/guidance/CT-Hydromodification-Requirements-Guidance.pdf>

1.4.3 Caltrans Statewide Stormwater Management Plan (SWMP)

The Caltrans Permit directs Caltrans to implement and maintain an effective SWMP. The SWMP is the document that describes how Caltrans plans to implement the Permit requirements. The SWMP describes Caltrans' program and addresses stormwater pollution control related to various activities, including planning, design, construction, maintenance, and operation of roadways and facilities, and presents key implementation responsibilities and schedules.

The SWMP was updated in July 2016 and is available at:

http://www.waterboards.ca.gov/water_issues/programs/stormwater/docs/caltrans/swmp/swmp_approved.pdf

1.4.4 Construction General Permit (CGP)

The SWRCB elected to adopt a single statewide general permit for construction activities that applies to all stormwater discharges from land where clearing, grading, and excavation result in soil disturbance of at least one (1) acre or more. Construction activity that results in soil disturbance of less than one (1) acre is subject to this CGP if there is the potential for significant water quality impairment resulting from the activity as determined by the RWQCB. The CGP requires owners of land where construction activity occurs and meets the permit criteria to develop a Stormwater Pollution Prevention Plan (SWPPP) (see Section 1.4.5). The department must meet the substantive requirements of the CGP:

http://www.waterboards.ca.gov/water_issues/programs/stormwater/construction.shtml.

Other CGPs that may apply, but are less common, include the EPA CGP that applies to tribal and federal lands, and the Tahoe CGP that applies to the Lake Tahoe Hydrologic Unit (i.e., watershed).

1.4.4.1 Rainfall Erosivity Waiver

Projects that have a disturbed soil area between one (1) and less than five (5) acres may qualify for a rainfall erosivity waiver if the rainfall erosivity factor (R factor) is less than a value of 5. The R factor takes into account project location, length of construction period, and time of year, so projects that begin and complete construction within a dry period may qualify for a waiver.

Refer to Section 6.4.4.2 for more detail.

1.4.5 Stormwater Pollution Prevention Plan (SWPPP)

The CGP outlines the required contents of a SWPPP. A SWPPP is a document that addresses water pollution controls for a specific project during construction. The CGP requires that all stormwater discharges associated with construction activities that result in soil disturbance of at least one (1) acre of total land area must comply with the provisions specified in the CGP, including development and implementation of an effective SWPPP. PEs are required to include pertinent SWPPP related information in the project file.

Prior to the start of construction, Caltrans will enter a Notice of Intent (NOI) and supporting documents to the SWRCBs *Stormwater Multiple Application and Report Tracking System* (SMARTS). The SWPPP is typically prepared by the contractor and authorized by the Resident Engineer (RE) prior to commencement of soil-disturbing activities. When construction is complete and the construction site is stabilized, Caltrans will submit a Notice of Termination (NOT) in SMARTS.

1.4.6 Water Pollution Control Program (WPCP)

Generally, construction projects with a disturbed soil area of less than one (1) acre are not covered under the CGP and do not require a SWPPP. For all projects that do not require preparation of a SWPPP, Caltrans requires that a Water Pollution Control Program (WPCP) be prepared. The WPCP is typically prepared by the contractor and authorized by the RE prior to commencement of soil-disturbing activities. Details on the preparation of the SWPPP or WPCP are found in the supplementary Stormwater Quality Handbook, *Stormwater Pollution Prevention Plan (SWPPP) and Water Pollution Control Program (WPCP) Preparation Manual*.

1.4.7 Additional Requirements

Regulatory agencies may impose requirements in addition to the Caltrans Permit if special conditions warrant. These additional requirements may affect the overall design as it relates to drainage and water quality. Some of the additional requirements may include:

- Waste Discharge Requirements (WDR), from RWQCB;
- Soil Management Agreement for Aerially Deposited Lead (ADL)-Contaminated Soils with Department of Toxic Substances Control (DTSC), referred to as the ADL Agreement;
- 1602 Permits from the California Department of Fish & Wildlife;
- 404 Permit from the Army Corps of Engineers (ACOE);
- 401 Certification from the RWQCB;
- Dewatering Permits from RWQCB;
- Reclamation District Requirements;
- Coastal Development Permit from Coastal Commission; and
- Other Permits or Requirements related to stormwater

An example of an additional project requirement is the ADL variance issued by the California DTSC for the reuse of some soils that contain elevated lead levels. There are numerous design considerations, soil types must be documented on the plans and properly addressed in the specifications, and regulatory agencies must be notified as the project progresses. PEs must coordinate with the appropriate district hazardous waste representative to ensure they meet all of the ADL Agreement requirements and comply with other regulations regarding hazardous waste.

Some projects may require WDRs, additional permits, or other environmental requirements. The PE should check the environmental document and other supporting documents (*Water Quality Assessment Report* [WQAR] or equivalent) for all water quality related requirements.

Regional and local requirements may need to be considered for projects that include work outside of Caltrans' RW. The relevant requirements should be referenced in the environmental documents prepared during the PA/ED phase (e.g., WQAR). Coordination with regional or local agencies and municipalities should be conducted throughout all phases of project to ensure compliance with applicable NPDES permits. As appropriate, coordination and design efforts should be documented in the Stormwater Data Report and reflected in the PS&E documents.

1.5 Permit and SWMP Implementation

The Headquarters (HQ) Division of Environmental Analysis coordinates implementation of the SWMP with each district or region and with other HQ divisions, including Design, Maintenance, Construction, and Traffic Operations. Each district is responsible for implementing the SWMP within the district and complying with the Caltrans Permit and CGP requirements and any district or region specific requirements. Program responsibility matrices have been developed specifically for each district or region and are available from District/Regional NPDES Coordinators.

1.5.1 District Work Plans (DWP)

The Caltrans Permit requires that Caltrans develop and submit DWPs to the SWRCB each year as part of the Annual Report. The DWPs are also forwarded to the appropriate RWQCB Executive. The DWPs describe activities that will be conducted by the districts during the upcoming fiscal year to implement the SWMP. Caltrans, in coordination with the SWRCB and the RWQCBs, has developed a standard format for the development and submittal of these DWPs. These DWPs are organized as follows:

- Section 1 – Introduction;
- Section 2 – District Personnel and Responsibilities;
- Section 3 – District Facilities and Water Bodies;
- Section 4 – Drinking Water Reservoirs and Recharge Facilities;
- Section 5 – Slopes Prone to Erosion;
- Section 6 – Implementation; and
- Section 7 – Region Specific Activities.

The districts coordinate and meet with the appropriate RWQCBs to discuss the proposed DWPs at least 30 days prior to their submittal due date each year.

2 Design Program Responsibilities

2.1 Introduction to Design Program Responsibilities

The Caltrans Project Delivery Stormwater Management Program includes Headquarters and district representatives from the following divisions: Environmental Analysis, Design, Construction, Engineering Services, Project Management, and Right-of-Way & Land Surveys.

This section describes roles and responsibilities of certain functional units as they pertain to the stormwater program, as well as other efforts necessary to assure compliance. This will provide the Project Engineer (PE) an understanding of roles and responsibilities and how other staff is involved in the development of the stormwater strategy for a project.

2.2 Management

The role of the Office of Hydraulics and Stormwater Design (OHSD) includes:

- **Coordination:** In coordination with the Division of Environmental Analysis, OHSD provides general guidance to the districts on the implementation of stormwater quality management practices.
- **Program Evaluation:** OHSD assesses district incorporation of stormwater quality management features into project planning and designs. Provides continuous improvement by performing design compliance monitoring.
- **Reporting:** OHSD assists the Division of Environmental Analysis (DEA) Water Quality Program in the preparation of the Annual Report to the California State Water Resources Control Board (SWRCB), as it relates to Design activities.

The Design Division Chief is responsible for statewide implementation policies, procedures and guidance, and management of the personnel of the Design program. This includes the responsibility for ensuring compliance with all elements of the *Statewide Stormwater Management Plan* (SWMP) that are required to be implemented by the Division of Design. The Design Division Chief is also responsible for representing design on the Headquarters Stormwater Management Team and the Water Quality Management Assurance Team (see SWMP Section 2.2.3).

2.3 Stormwater Advisory Teams (SWATs)

The OHSD staff provides input and consultation to the following Stormwater Advisory Teams (SWATs):

- The Project Design SWAT (PD-SWAT) is composed of District/Regional Design Stormwater Coordinators, related functional units, and representatives from each of the affected HQ Divisions. The PD-SWAT provides review of proposed and existing BMPs utilized in the planning and design of projects. BMPs include Construction Site BMPs, Design Pollution Prevention (DPP) BMPs, and Treatment BMPs. In addition, the PD-SWAT reviews and assists in the development of training classes and guidance documents for implementing stormwater activities relevant to project design.

- The Maintenance SWAT (M-SWAT) is composed of District Maintenance Stormwater Coordinators and representatives from each of the affected HQ Divisions. The M-SWAT provides any necessary review and/or evaluation of proposed and existing Best Management Practices (BMPs) used by the Division of Maintenance. In addition, the M-SWAT reviews and assists in the development of training classes and guidance documents for implementing stormwater activities described in the SWMP for maintaining highways, bridges, facilities, and other appurtenances related to transportation.
- Construction SWAT (C-SWAT) is composed of District Construction Stormwater Coordinators and representatives from each of the affected HQ Divisions. The C-SWAT provides review of proposed and existing Construction Site BMPs and measures used for stabilization of soils. In addition, the C-SWAT reviews and assists in the development of training classes and guidance documents for implementing stormwater activities relevant to construction activities.
- Encroachment Permit SWAT (EP-SWAT) is composed of District Permit Coordinators and representatives from each of the affected HQ Divisions. The EP-SWAT provides review of existing procedures to ensure that they integrate the appropriate stormwater BMPs into the requirements of encroachment permits. In addition, the EP-SWAT reviews and assists in issuing and administering encroachment permits.
- The Water Quality SWAT (WQ-SWAT) is composed of the District/Regional National Pollutant Discharge Elimination System (NPDES) Coordinators and representatives from each of the affected HQ Divisions. The WQ-SWAT provides review of proposed and existing Treatment BMPs, and prioritizes research or studies of Treatment BMPs. The WQ-SWAT is a forum for discussing stormwater coordination activities underway or planned with other municipalities, reviewing and recommending public education efforts, sharing technical information, providing advice on compliance issues, and resolving issues of dispute on stormwater. Many of these activities result in recommendations for changes to the SWMP or policies and other documents on stormwater. The WQ-SWAT discusses stormwater budget allocations for the districts and HQ Divisions. The WQ-SWAT reviews data and findings from compliance-monitoring and evaluation activities, and recommends changes in practices to improve compliance efforts.

2.4 Stormwater Coordinators

All Districts/Regions have designated stormwater coordinators. Functional-unit stormwater coordinators exist in the Environmental, Design, Construction, and Maintenance Divisions. Also, depending upon the complexity of the district, additional stormwater coordinators may be identified to represent other functional units or special needs; these roles are described in the District Work Plan (DWP). The functional unit coordinators assist the District Divisions in implementing stormwater management activities. The District/Regional Stormwater Coordinators serve as liaisons with the various HQ Stormwater functions. District/Regional NPDES Coordinator liaison activities include regular communications with representatives of the Regional Water Quality Control Boards (RWQCBs).

2.5 Responsibilities as They Relate to Encroachment Permits and Third-Party Activities

Districts control third-party activities on Caltrans RW (e.g., utility construction) through the conditions associated with encroachment permits. These conditions require compliance with Caltrans standard plans and specifications. Encroachment permits require environmental compliance, including

implementation of BMPs comparable to those required of Caltrans. In general, the design of large encroachments is overseen by District Design and construction activities by District Construction. Smaller projects are managed by the Encroachment Permit Unit.

2.6 Responsibilities for Coordination with Municipal Stormwater Permittees (Local Agencies)

Coordination with Municipal Separate Storm Sewer System (MS4) permit holders and other municipalities (cities and counties) must take place whenever a proposed project would result in stormwater discharges from the Department's stormwater drainage systems to stormwater drainage systems owned and operated by the MS4 or municipality, and vice versa. This coordination includes attending meetings, participating in special studies, identifying stormwater run-on issues, etc. The PE should consult with the District/Regional NPDES Coordinator to identify any MS4 concerns that may affect the project.

2.7 Consultation with Regional Water Quality Control Boards (RWQCBs) and Local Regulatory Agencies

Consultation with the RWQCBs and local regulatory agencies is strongly recommended to coordinate potential project issues (e.g., 401 certification) and develop consensus during project planning. The number of coordination meetings may vary depending upon the complexity of the stormwater quality issues, stormwater pollutants involved, and project site constraints. The District/Regional NPDES Coordinators are the liaisons between the RWQCBs and the districts.

2.8 Staff and Functional Units

2.8.1 Staff

Project Manager

Typically, the Project Manager (PM) is responsible for all project development phases from project initiation to closeout of the construction contract. The PM has full authority, delegated from the District Division Chief for Program and Project Management, to produce the results that were intended, meet schedules, stay within budget and keep the sponsors and customers satisfied.

During project initiation, the PM identifies the needs and expectations of the project sponsors. The PM also leads the Project Development Team (PDT) in the development of a "Project Work Plan" that defines the project scope, schedule, cost, and resource needs. Finally, the PM ensures that the Project Work Plan includes all the work required. Resources are assigned to a project based upon the Project Work Plan developed by the PM and the PDT.

During the PS&E phase of a project, the PM monitors project performance and resolves problems that affect project scope, cost or schedule; this includes the BMP evaluation and selection process for incorporation into the project. The PM coordinates the efforts of the overall team, and typically chairs the PDT meetings. During the entire process, the PM controls the project budget (both support and capital). The PM is required to sign the Long Form SWDR (Appendix E) at the conclusion of the Project Initiation Document (PID), the Project Approval/Environmental Document (PA/ED), and the

Plans Specifications, and Estimates (PS&E) phases. The PM also signs the Project Study Report (PSR) and the Project Report (PR).

Project Engineer

The PE is the registered civil engineer in responsible charge of appropriate project development documents (e.g., project study report, project report) and project design. The PE is a member of the PDT. Responsible charge of the work is defined in Section 6703 of the Professional Engineers Act of the California Business and Professions Code as “the independent control and direction, by use of initiative, skill and independent judgment, of the Chapter 2 – Roles and Responsibilities Section 3 – District Project Development Procedures Manual 02/12/2016 2-19 investigation or design of professional engineering work or direct engineering control of such projects.”

The PE coordinates closely with other functional units throughout the project development process and notifies other functional managers and staff of design changes as soon as feasible. Likewise, other functional units must communicate and coordinate closely with the PE whenever technical questions arise regarding the overall engineering effort. Each functional unit must keep the PM informed of those technical issues that will affect the overall cost, scope, schedule, or quality of the project. The PE, however, as the individual signing the title sheet, is responsible for the integration of all the engineering elements needed to make up a complete and comprehensive, quality plans, specifications, and estimate (PS&E) package. Only in this way can the project team continue to succeed in meeting their project delivery commitments.

District/Regional Design Stormwater Coordinator

The District/Regional Design Stormwater Coordinator is the main point of contact for PEs for project related stormwater questions and is responsible to support the project design compliance evaluation (PDCE) process. The Coordinator is also required to sign the SWDR at the conclusion of the PID, the PA/ED, and the PS&E phases. This authority may be delegated at their discretion.

District/Regional NPDES Coordinator

The District/Regional NPDES Coordinator verifies that the water quality issues are identified and incorporated in the Water Quality Assessment Report (WQAR), or equivalent document, (if one is prepared for the project). Based upon information submitted by the PE, the District/Regional NPDES Coordinator in consultation with the PDT and project sponsor, is responsible for assigning and crediting areas treated by the project and is responsible for entering project data into the Portal database¹.

Project Development Team (PDT)

For most projects, the Department uses a formalized PDT that acts as a steering committee in directing the course of studies required to evaluate the various project alternatives during the early phases of the project life cycle. The PDT uses an interdisciplinary approach that draws upon different disciplines in planning, developing, and evaluating alternatives. The PDT advises and assists the PM

¹ The Portal database is used for statewide treatment tracking.

in directing the course of studies, makes recommendations to the PM and district management, and works to carry out the Project Work Plan. The PDT is responsible for the completion of studies and the accumulation of data throughout project development to PS&E.

The primary functions of the PDT are as follows:

- To determine logical project limits;
- To recommend studies, timetables, alternatives, type of environmental documentation, and the feasibility of project impact mitigation measures;
- To ensure thorough analysis of the social, economic, environmental (including visual and aesthetic) and engineering aspects of the project. The PDT calls upon representatives of various disciplines as needed;
- To ensure that state and federal requirements for project development studies have been met;
- To use information in reports (PSR, Draft Project Report – Draft Environmental Document [DPR-DED], etc.) when recommending a preferred alternative to District Management for project approval;
- To evaluate the designation of treatment credit for the project, which may consist of Compliance Units (CUs) towards TMDLs and Alternative Compliance credit towards other district projects. The discretion on the final designation should come from the project sponsor; and
- To document the project history and decisions.

Functional Managers

Functional Managers supervise the Department functional units that provide technical data and plans to the PE, and schedule and resource data to the PM. Functional Managers are responsible for assigning staff to work on a project, and for ensuring the delivery of product(s) within the schedule agreed upon in the Project Work Plan. Functional Managers also ensure that the products comply with all applicable standards, regulations, and policies.

2.8.2 District Functional Units

Design

The District Design Unit is responsible for the implementation of Caltrans policies, programs, and procedures concerning design of Caltrans facilities. This includes ensuring compliance with all design elements of the *Highway Design Manual (HDM)*, the *Project Development Procedures Manual (PDPM)*, the *Project Planning Design Guide (PPDG)*, and other guidance documents. All Treatment BMPs will be designed to follow the Professional Engineers Act for civil engineering work². The Design Unit is responsible for the following stormwater quality related activities:

² Civil engineering work includes grading, drainage, irrigation, floodplains, inland water ways, highway design, water purification, and any other fixed object on the roadside. The PE is in responsible charge for ensuring civil engineering work is correctly performed (e.g., stamping plans, calculations, specifications, design reports).

- Preparation of a PID and a PR during the project planning phase, including evaluation and selection of potential BMPs that may be incorporated into the project;
- Preparation of PS&E documents. This includes the selection and design of DPP BMPs, Treatment BMPs, and appropriate Construction Site BMPs into the plans and specifications;
- Determining whether an SWPPP or a WPCP is required for the project;
- Coordinating with District Hazardous Waste Unit to ensure compliance with the Aerially Deposited Lead (ADL) Agreement and other regulations regarding hazardous waste. There are numerous design considerations for ADL soils, soil types must be documented on the plans and properly addressed in the specifications, and regulatory agencies must be notified as the project progresses; and
- Preparing the design information necessary to enter into Stormwater Multiple Application Report Tracking System (SMARTS) to support project construction.

Environmental

The District's Environmental Unit is responsible for the implementation of Caltrans policies, programs, and procedures concerning environmental considerations, analysis, and compliance with environmental laws and regulations under California Environmental Quality Act (CEQA) and National Environmental Policy Act (NEPA) as well as other state and federal regulations. Key responsibilities of the Environmental Unit include the following:

- Define stormwater quality issues in coordination with the PE and the District/Regional NPDES Coordinator;
- Identify receiving water bodies and their beneficial uses, 303(d) listed water bodies, Total Maximum Daily Loads (TMDLs), and project-related stormwater discharges and quality;
- Prepare the Preliminary Environmental Assessment Report (PEAR);
- Evaluate potential water quality impacts to the water quality of receiving waters in coordination with the PE and the District/Regional NPDES Coordinator;
- Prepare the WQAR, or equivalent document as required;
- Provide input to the PE regarding information to be incorporated into the SWDR; and
- Make recommendations to the PDT regarding the avoidance, minimization and mitigation measures relating to compliance with the CEQA.

This functional unit is known by various names in different districts, including, but not limited to, Environmental, Environmental Planning, Environmental Analysis, Environmental Engineering, and Environmental Oversight. A representative from this unit is a required member of the PDT.

The PEAR is prepared by the Environmental Unit. The purpose of the PEAR is to determine whether there are any potentially significant environmental issues that could affect the viability of the project alternatives. The PEAR identifies the environmental documents and supporting technical studies that would be required in subsequent project development processes to address potential environmental impacts. Based upon the potential for significant impacts, the PEAR identifies whether a CEQA Initial Study or Environmental Impact Report is needed and/or whether a NEPA Environmental Assessment or Environmental Impact Statement is needed. Potential water quality impacts are identified in the PEAR.

The WQAR is typically prepared by the Environmental Unit. The WQAR, or equivalent document, at different levels of detail describes existing water quality conditions, identifies potential project impacts, and proposes avoidance and minimization measures. This information will be utilized by Design, Construction, and Maintenance staff to develop and implement specific BMPs to mitigate any potential water quality impacts associated with stormwater discharges from the proposed project. The information from the PEAR and the WQAR will be utilized in the development of the SWDR and associated checklists.

The District Hazardous Waste Unit is usually resourced under the District's Environmental Unit. This unit is responsible for investigating the presence of ADL soil and other potentially hazardous materials with respect to any future disposal and handling; Waste Discharge Requirements (WDRs) issued from the RWQCB; and ability to reuse materials within or outside the project limits. The ADL Agreement with DTSC allows for reuse of regulated soil under specific conditions. The PE, District/Regional NPDES Coordinator, and the District Hazardous Waste Unit should coordinate on items such as notification procedures under the ADL Agreement and possibility of WDRs, as well as stabilization of cover materials at reuse locations, distance from groundwater and culverts, placement of irrigation systems, and landscape design as it relates to cover thickness.

Surveys

The District's Surveys Unit is responsible for the implementation of Caltrans policies and procedures concerning surveys and for conducting surveys.

Survey needs should be evaluated and identified early in the project initiation process and throughout the entire project development process when needed. During a project evaluation, areas are identified as possible locations for Treatment BMPs. Therefore, surveys should be developed for these areas. After the first evaluation of survey needs, the PE should submit the initial survey request accompanied by a strip map. The extent of the survey will depend on the type of project, existing information available, sensitivity of the area of potential effect, and the number of viable project alternatives. The Right-of-Way Branch and the Environmental Unit require accurate mapping in order to properly carry out their functions, so their needs must be carefully considered when evaluating surveys.

Right-of-Way

The District's Right-of-Way Branch is responsible for the implementation of Caltrans policies, programs and procedures concerning RW and utility considerations and compliance with state and federal laws and regulations. This function consists of various branches in the districts under a District Division Chief for Right-of-Way, except for the Right-of-Way Engineering Unit which generally reports to another District Division Chief.

Because most transportation projects in California require RW, utility easements, rights of entry, or some other RW activity, the project development process requires close coordination between the PE, the PM, and representatives from the Right-of-Way Engineering Unit and the Right-of-Way Branch to determine schedules and cost estimates, and to assure the acquisition of all necessary property rights.

The Right-of-Way Branch provides valuable information at the initiation of studies. Once the project limits have been tentatively determined, property ownership maps can be developed by the Right-of-Way Engineering Unit. Preliminary RW estimates are required to properly develop and analyze project

alternatives, including Treatment BMPs. The RW data sheet should be requested from the Right-of-Way functional unit as soon as possible after project alternatives have been developed. The RW data sheet is prepared during the PID process and updated throughout the Project Approval/ Environmental Document (PA/ED) process, and is a required attachment to the PSR, the PR, and most other project initiation and project approval documents. The information in the right-of-way data sheet is vital to the project development process since it details all types of parcel information and the right-of-way estimate. The information from the RW data sheet is also used to evaluate the feasibility of acquiring additional land for the incorporation of Treatment BMPs or drainage easements.

Adequate mapping is required, as well as realistic project scope. A representative of the Right-of-Way Branch is a required member of the PDT.

Materials and Geotechnical

Materials and geotechnical information is required for almost all projects, usually related to pavement design, maximum slope gradients, culvert selection, corrosion studies, and material sites. The District Materials Unit is involved throughout the project development process; after the project has been initiated, requests are made of the District's Materials Unit to update materials information. The District Materials Unit provides a Materials Report for all projects that involve any of the following components:

- Pavement structure recommendations and/or pavement studies;
- Culverts (or other drainage materials); or
- Corrosion studies.

If projects are located in areas where there are concerns such as gross slope stability, foundation problems, seismic, percolation, etc., preliminary evaluation should be made by Division of Engineering Services (DES) Geotechnical Design unit. After the project has been initiated, requests should be directed to the DES Geotechnical Design unit to provide geotechnical information such as side slope recommendations, slide locations, etc. For projects implementing permanent stormwater treatment measures, percolation tests or information regarding the infiltration rate of native soil or fill and seasonal high groundwater should be requested as early as possible. It is essential that sufficient geotechnical information be developed so that all viable project alternatives are evaluated at all phases of the project development process. If a project includes new slope ratios steeper than 2:1 (h:v), then a Geotechnical Design Report should be prepared. Projects including slopes between 4:1 and 2:1 (h:v) should be coordinated with DES Geotechnical Design unit.

Geotechnical Services either prepares or approves a Geotechnical Design Report for all projects incorporating new cut slopes or embankments steeper than 2:1 (h:v), retaining walls, groundwater studies, slide prone areas with erosive soils, and any other studies involving geotechnical investigations and engineering geology including infiltration testing.

The PE uses the recommendations from these units to develop and analyze alternatives and estimate costs for use in project initiation and approval documents, and to prepare estimates, plans and specifications for both new construction and rehabilitation projects.

It is essential that enough materials information is available so that all viable project alternatives are evaluated at all phases of the project development process.

Hydraulics

The District Division of Design is responsible for hydraulic design procedures. The Design unit that performs the project drainage design is responsible for the implementation of these policies and procedures. District organizations differ, but for the purpose of this document, it is assumed that the PE is responsible for ensuring that proper project drainage is designed and that project stormwater treatment requirements are met. This may require the active participation in, or the review of, the design by the Hydraulics Unit. District Hydraulic Units may perform a variety of drainage related analysis and design. See Caltrans HDM Topic 802.1 (4)(g) for a listing of recommended activities. The Hydraulics Unit may conduct the rapid stability assessment (RSA) of stream crossings within a project, but does this with the assistance of other functional units. If a level 2 or 3 stability assessment is needed after the RSA, then the Hydraulics Unit would produce it.

Detailed drainage design, such as accurate sizing and location of the storm drain system (e.g., culverts, inlets, Treatment BMPs), and roadway drainage, does not begin until after selection of the preferred alternative and approval of a project. However, the Hydraulics Unit should be involved during the entire project planning process. Their input in the project initiation process is invaluable, particularly in recommending facility types and estimating costs of large facilities.

Following project approval, a Drainage Report is typically prepared by the Hydraulics Unit. This report covers rainfall, runoff, existing flood records, gauging stations, debris, and any other pertinent drainage information. This report is transmitted to the PE so that pertinent drainage design can be started. The information in the Drainage Report is also used to evaluate and design stormwater BMPs.

The Hydraulics Unit should also be involved in the environmental studies. Early coordination between the two functional groups is important. Many projects, by necessity, will include water quality enhancement features or encroach on wetlands, floodplains, etc. When floodplain encroachment is required, the Hydraulics Unit should be involved in preparing the technical information. Historical drainage maps often depict the extent of the encroachment and help determine which project alternatives should be considered. Documentation of these features must be included in the DPR.

Construction

The Construction Unit is responsible for administering contracts for the construction of projects by contractors to ensure that the final products are in accordance with the plans and specifications, and to resolve any problems that may arise in the process. The Construction Unit should review the project and BMP alternatives to determine if they are biddable and buildable. During environmental and project studies, the Construction Unit should be involved in the determination of measures to reduce or mitigate construction impacts.

Throughout the project development process, the Construction Unit should review the project plans and specifications for such things as constructability, construction safety, logical staging, the analysis of the number of working days, supplemental funds, and special provisions usability. Also, the Construction Unit provides advice and concurrence to the PE for strategy, development, and inclusion of Construction Site BMPs into the project plans. Construction concurrence with the Construction Site BMP strategy should be documented in the SWDR.

Prior to start of construction, the PE, along with other involved district units, will go over the project with the RE. The review at this phase will aid in describing reasons for design decisions and



commitments such as; RW obligations, signing and traffic handling, materials sites, selected material, foundation treatment, potential slides, environmental commitments, drainage, potential maintenance issues, erosion control, public notification, proprietary materials, special considerations in contract special provisions, etc.

On almost all construction projects, developments in the field will necessitate some design changes. For early resolution of these changes, the RE, the PM, and the PE may coordinate with other functional units to accommodate these changes without affecting scope, schedule, and budget. After completion of the construction contract, the PM is responsible for gathering the construction contract records from the RE and the project planning and design data from the PE to put in the Project History File.

Maintenance

The Maintenance Unit will be responsible for maintaining the highway and any new infrastructure, including permanent BMPs, once the project is complete. It is essential that the Maintenance Unit be involved in the project development process from conception through construction. Maintenance is required to sign the Long Form SWDR (Appendix E) at the conclusion of the PID, the PA/ED, and the PS&E phases.

The Maintenance Unit field representatives have a unique insight into local problems and maintenance and safety concerns. This insight must be utilized in the project development process. Coordination with maintenance staff during the project development process can minimize future maintenance problems and the potential for future lawsuits.

The Maintenance Unit should review all major engineering reports such as the PSR, DPR, PR, etc. and the draft Contract Plans. The review shall include the evaluation of all proposed BMPs, including the maintainability of those BMPs. Maintenance concurrence must be obtained on any new slope steeper than 2:1 (h:v). Maintenance Units should also participate in the preparation of maintenance agreements (setting maintenance control limits).

Typical Maintenance Unit involvement would be to comment on features such as the following:

- Drainage patterns – particularly known areas of flooding, debris, etc.;
- Shoulder backing material;
- Stability of slopes and roadbed;
- Help determine if the project can be built and maintained economically;
- Possible material borrow or spoil sites;
- Concerns of the local residents;
- Existing and potential erosion problems;
- Facilities within the RW that would affect alternative designs;
- Special problems such as deer crossings, endangered species, etc.;
- Traffic operational problems such as unreported accidents, etc.;
- Facilities that are safe to access and maintain;
- Providing concurrence on any slopes steeper than 2:1 (h:v);

- Known environmentally sensitive areas;
- Potential staging areas;
- Snow storage areas; and
- Frequency of traction sand use and estimate of quantity applied annually.

Landscape Architecture

District Landscape Architecture is responsible for the implementation of Caltrans policies, programs, procedures, and standards for most aspects of highway planting, highway planting restoration, replacement planting, revegetation, vegetative erosion control, safety roadside rest areas, vista points, and scenic corridors. All landscape work will be designed to follow the Landscape Architecture Practice Act.

The Landscape Architect should evaluate the vegetation strategy for all DPP BMPs (esp. slope surface protection) proposed in the project plans. The District Landscape Architect (DLA) typically prepares an erosion control plan for disturbed soil areas as determined by the PDT. The DLA supports development of the final soils stabilization (RUSLE2) calculations and is responsible to ensure the project is compliant with the Model Water Efficient Landscape Ordinance (MWELo) requirements included in the Caltrans Permit. Guidance on water conservation and the MWELo is available at: <http://www.dot.ca.gov/design/lap/>

Additionally, several approved permanent BMPs require the establishment of vegetation. The DLA shall provide recommendations for vegetation establishment when these BMPs are considered. Projects incorporating new slopes steeper than 4:1 (h:v) must be approved by a licensed civil engineer and the DLA for approval of the vegetation strategy and soil amendments to support vegetation. The SWDR is the document by which the DLA gives concurrence for vegetation on slopes greater than 4:1, and includes a description of the permanent erosion control strategy. Landscape Architecture is required to sign the Long Form SWDR (Appendix E) at the conclusion of the PID, the PA/ED, and the PS&E phases.

THIS PAGE INTENTIONALLY LEFT BLANK.

3 Best Management Practice Overview

3.1 Introduction

This section of the Project Planning Design Guide (PPDG) provides Project Engineers (PEs) with background information on the process and procedures for evaluating project site conditions to determine the need for incorporating Best Management Practices (BMPs) into projects. The following sub-sections describe pollutants of concern and provide an introduction to the various approved BMPs that can be used by PEs.

3.2 Identification of Water Quality Requirements for Project Planning Purposes

The appropriate selection of BMPs requires the PE to have an understanding of the process used to identify water quality requirements and pollutants of concern for specific water bodies. The Regional Water Quality Control Board (RWQCB) plays an important role in identifying the pollutants of concern. Water quality standards, Clean Water Act (CWA) Section 303(d) list, Total Maximum Daily Loads (TMDLs) and Basin Plans developed by the RWQCBs are important references for the identification of pollutants that need to be addressed.

The process of identifying water quality requirements includes close coordination with the District Environmental Unit and the District/Regional National Pollutant Discharge Elimination System (NPDES) Coordinator. The PE initiates the process of compiling information regarding water quality requirements as identified in the checklists provided in Appendix E. The Environmental Unit and the PE then exchange the information necessary to (1) prepare documents regarding the assessment of water quality impacts, (2) determine whether Treatment BMPs should be considered, and (3) select and design BMPs, which is the responsibility of the PE. This information exchange continues to take place throughout the Project Initiation Document (PID), Project Approval/Environmental Document (PA/ED), and the Plans, Specifications, and Estimates (PS&E) processes. The Environmental Unit uses the shared information to prepare a Water Quality Assessment Report (WQAR) or equivalent document. The WQARs are technical water quality assessment documents required to support the Environmental Document. The PE uses the shared information from the WQAR to complete the Stormwater Data Report (SWDR) as described in Appendix E.

3.2.1 State Water Resources Control Board (SWRCB) and Regional Water Quality Control Boards (RWQCBs)

The mission of the SWRCB is to preserve, enhance and restore the quality of California's water resources, and ensure their proper allocation and efficient use for the benefit of present and future generations. The California Water Code divides the state of California into nine regions, based on major drainage areas. Nine RWQCBs act to protect water quality within these regions. The nine RWQCBs and their offices are:

- Region 1- North Coast (Santa Rosa);
- Region 2- San Francisco Bay (Oakland);
- Region 3- Central Coast (San Luis Obispo);
- Region 4- Los Angeles (Los Angeles);
- Region 5- Central Valley (Redding);
- Region 5- Central Valley (Fresno);
- Region 5- Central Valley (Sacramento);
- Region 6- Lahontan (Victorville);
- Region 6- Lahontan (South Lake Tahoe);
- Region 7- Colorado River (Palm Desert);
- Region 8- Santa Ana River (Riverside); and
- Region 9- San Diego (San Diego).

Figure 3-1 is a map showing the RWQCB jurisdictions.

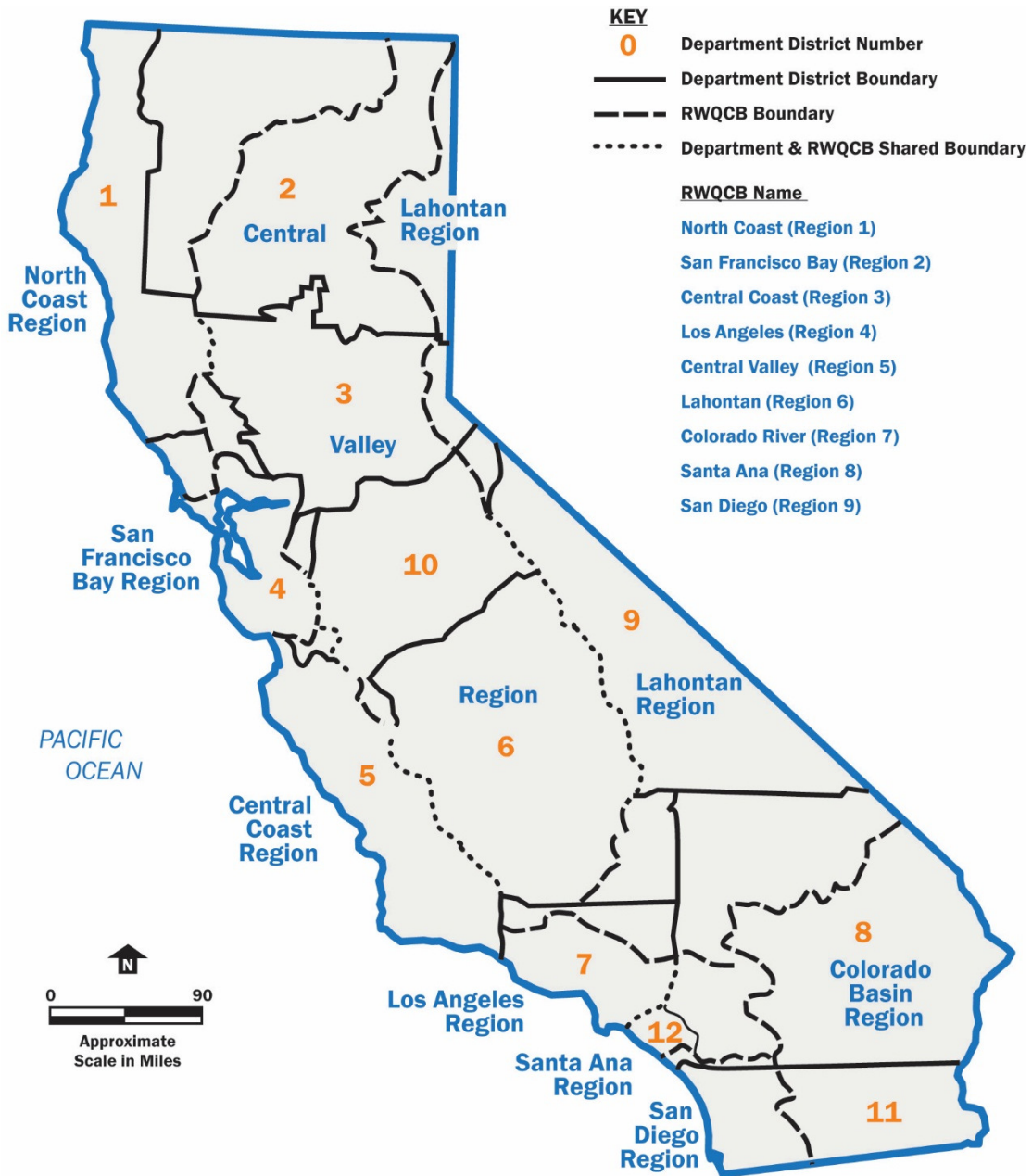

Figure 3-1. Map of California with RWQCB and District Boundaries

In protecting water quality, each RWQCB:

- Adopts a region-specific Water Quality Control Plan or Basin Plan that contains water quality standards specific to the region's waters;
- Issues Waste Discharge Requirements (WDRs) and water quality monitoring and reporting programs that implement the statewide policy and regulations of the SWRCB along with the region-specific water quality standards specified in the Basin Plan; and
- Implements enforceable orders against violations of statewide and region-specific requirements.

3.2.2 Resources for Identifying Pollution Control Requirements

Proper selection and design of BMPs require an understanding of the applicable pollution control requirements. PEs should coordinate with the District/Regional NPDES Coordinators to ensure that all relevant water quality requirements are identified. Water quality requirements come from a variety of sources, including, but not limited to:

- RWQCB Basin Plans;
- TMDLs and 303(d) lists;
- WDRs; and
- Water Quality Certification under Section 401 of the CWA.

The following sub-sections provide a brief description of these sources of pollution control requirements. While the PE normally obtains this information from the Environmental Unit, PEs should be aware that Basin Plans, TMDLs, and 303(d) listings can change over time and that it may be necessary to reconfirm the pollution control requirements at different phases in the project development process.

3.2.2.1 Regional Water Quality Control Board Basin Plans

Each RWQCB has developed a Basin Plan to identify designated beneficial uses and water quality objectives for their jurisdictional regions. The Basin Plans are available online by accessing the SWRCB web site at www.swrcb.ca.gov and selecting the link for the appropriate RWQCB. Each individual RWQCB web page includes a link to access the corresponding Basin Plan.

A comprehensive Geographic Information System (GIS) database of all of the beneficial uses, water quality objectives, 303(d) listed waterbodies, watershed boundaries, watershed data, Caltrans facility locations, and other information can be accessed using the Water Quality Planning Tool available at: <http://svctenvims.dot.ca.gov/wqpt/wqpt.aspx>.

3.2.2.2 Total Maximum Daily Loads (TMDLs) and 303(d) Lists

Section 303(d) of the 1972 Federal Water Pollution Control Act requires priority rankings for water bodies for which the beneficial uses are listed as impaired by pollution, and also requires the establishment of TMDLs to protect water quality of these impaired water bodies from specific pollutants. In response to this requirement, the U.S. Environmental Protection Agency (EPA) has

developed a 303(d) list for each state that identifies specific pollutants causing impairment of specific receiving waters.

3.2.2.3 401 Certifications and Waste Discharge Requirements (WDRs)

Under the CWA, any project requiring a federal license or permit that may result in a discharge to a Water of the U.S. must obtain a 401 Certification, which certifies that the project will be in compliance with State water quality standards. The most common federal permit triggering 401 Certification is CWA Section 404 permits issued by the U.S. Army Corps of Engineers (Corps). In addition, the SWRCB has pre-certified some activities under some of the “Nationwide” 404 Permits issued by the Corps, but these instances should be validated with the RWQCB.

In some cases, the RWQCB may have specific concerns with discharges associated with a project. As a result, the RWQCB may issue a set of requirements, known as WDRs under the State Water Code that define activities, such as inclusion of specific features, effluent limitations, monitoring, and plan submittals that are to be implemented for protecting or benefiting water quality. WDRs can be issued to address both permanent and temporary discharges of a project. It is most common to issue WDRs in conjunction with obtaining a 401 Certification under the CWA.

3.2.3 Stormwater Documents

The WQAR, or equivalent document, and the SWDR are the two project-specific stormwater documents prepared by a district. The District Environmental Unit typically prepares the WQAR, while the PE prepares the SWDR. At the PA/ED phase, these documents are prepared concurrently, and require coordination between the PE, the Environmental staff preparing the WQAR, or equivalent document, and the District/Regional NPDES Coordinator.

A WQAR, or equivalent document, will identify applicable stormwater regulations and potential stormwater impacts to be addressed. The WQAR also identifies the receiving water, evaluates the existing surface water quality, identifies potential project-related stormwater discharges, and evaluates the potential project-related stormwater impacts on the receiving water quality. The WQAR, or equivalent document, is typically prepared as support documentation during the California Environmental Quality Act (CEQA) and National Environmental Policy Act (NEPA) environmental review phase of a project.

The SWDR documents the relevant stormwater design decisions made regarding project compliance with Caltrans Permit, the *Construction General Permit* (CGP), and additional stormwater quality requirements (see Section 1.4). The preliminary information in the SWDR prepared during the PID phase will be reviewed, updated, confirmed, and if required, revised in the SWDR prepared for the later phases of the project. The information contained in the SWDR and the WQAR, or equivalent document may be used to make more informed decisions regarding the selection of BMPs and/or recommended avoidance, minimization or mitigation measures to address water quality impacts for CEQA compliance. **The SWDR shall not be referenced in the Environmental Document or the WQAR.**

3.2.4 Targeted Design Constituents (TDC)

A Targeted Design Constituent (TDC) is a pollutant that has been identified during Departmental runoff characterization studies to be discharging with a load or concentration that commonly exceeds allowable standards and which is considered treatable by currently available Department-

approved Treatment BMPs. The TDC approach is the Department's statewide design guidance to address the primary pollutants of concern.

TDCs are: phosphorus; nitrogen; total copper; dissolved copper; total lead; dissolved lead; total zinc; dissolved zinc; sediments; and general metals [unspecified metals]. These TDCs and other pollutants of concern are discussed in detail in the following sections.

3.2.5 Pollutants of Concern

Selection of BMPs requires an understanding of the types of pollutants that the BMPs are designed to remove. Brief descriptions of commonly encountered pollutants are provided in the following sub-sections. Table 3-1 provides a list of pollutants and the types of Treatment BMPs that can be used to reduce the discharge of the pollutants. This list covers all TMDL or 303d listed pollutants that Caltrans will likely encounter. The table should be used along with the T-1 checklist to select the appropriate BMPs. Use Matrix A for general purpose pollutant removal if a pollutant of concern (POC) is not specifically listed when considering Treatment BMPs.

3.2.5.1 Solids (Suspended and Dissolved)

The amount of solids in water is defined by standard testing procedures. Total solids in a water sample is the residue left in a vessel after evaporation and drying in an oven; it includes Total Suspended Solids (TSS) the portion retained by a filter and Total Dissolved Solids (TDS) the portion that passes through the filter. Discharges containing solids (suspended and dissolved) may negatively affect the quality of waters and therefore are used as indicators of water quality and regulatory compliance with NPDES permits, usually shown as (mg/L). **Selenium** and **chlorides** may be found as dissolved solids in stormwater runoff.

Selenium is a naturally occurring mineral in ancient sea bed geologic formations, oil extraction, and agricultural runoff. Selenium is an essential mineral in low concentrations, but can be toxic at high concentrations. Caltrans is listed in TMDLs, but is not a significant source in most watersheds. The best BMPs for most locations are source control and stabilization of eroding soils as these are pollution prevention methods that prevent selenium from entering stormwater. Once in stormwater it is difficult and expensive to remove selenium.

Solids can be present in the water column in a dissolved phase (TDS) or a suspended phase (TSS). In general, suspended solids are considered a pollutant when they significantly exceed natural concentrations and have a detrimental effect on the beneficial uses designated for the receiving water. Possible sources of TSS from Caltrans facilities include natural erosion, failed slopes, runoff from construction sites, and other operations where the surface of the ground is disturbed. In addition, increased runoff from new impervious surfaces can accelerate the process of channel erosion, which in turn can increase TSS (and TDS) in runoff.

When selecting Treatment BMPs for these pollutants, use Matrix A for general purpose pollutant removal and source control BMPs.

SECTION THREE

Best Management Practice Overview

Table 3 1. Pollutants of Concern from Typical Highway Runoff and Applicable Treatment BMPs

	DPPA	Biofiltration Systems	Infiltration Devices	Detention Devices	Dry Weather Flow Diversion ¹	Gross Solids Removal Devices	Multi-Chambered Treatment Train	Media Filters ⁹	Wet Basin	Traction Sand Traps	Bioretention	OGFC
Total Suspended Solids	✓	✓	✓	✓	✓		✓	✓	✓	✓	✓	✓
Total Dissolved Solids ⁷	✓		✓		✓							
Nutrients	✓	✓ ⁴	✓	✓ ⁴	✓		✓	✓ ²	✓ ⁴			✓ ²
Pesticides ⁵	✓	✓ ^{4,5}	✓	✓ ⁵	✓		✓ ⁵	✓ ⁵	✓		✓ ⁵	✓ ⁵
Particulate Metals	✓	✓	✓	✓	✓		✓	✓	✓		✓	✓
Dissolved Metals	✓ ⁴	✓ ³	✓ ⁴		✓			✓ ³				
Pathogens and Bacteria	✓	✓	✓	✓	✓				✓		✓	
Litter/Trash ¹⁰			✓ ⁶	✓	✓	✓	✓	✓	✓	✓	✓	
Biochemical Oxygen Demnd ⁸	✓	✓	✓		✓			✓			✓	
Turbidity	✓	✓	✓	✓	✓		✓	✓		✓	✓	✓
Temperature	✓ ⁵	✓ ⁵	✓ ⁵	✓ ⁵				✓ ⁵	✓ ⁵		✓ ⁵	✓ ⁵
Mercury	✓	✓ ⁵	✓	✓ ⁵	✓						✓ ⁵	✓ ⁵

¹ Dry Weather Flow Diversions address non-stormwater flows only.

² Phosphorus and Nitrogen for the Austin Sand Filter; Phosphorus only for the Delaware Sand Filter and OGFC.

³ Dissolved metals vary see T-1 for appropriate BMP selection.

⁴ Soil needs to have adequate infiltration capacity for some pollutants of concern, see T-1 Checklist.

⁵ Treatment BMPs are listed based on their effectiveness at removing sediment.

⁶ Trenches excluded.

⁷ Total dissolved solids may include Chlorides and Selenium.

⁸ BOD is typically used to assess water quality and how it will affect dissolved oxygen levels

⁹ Media filters can use alternative media, which may vary pollutant removal (sand, compost, activated alumina, or others); see guidance document.

¹⁰ Trash effectiveness requires addition of screen for many treatment BMPs.

3.2.5.2 Nutrients

Excessive inputs of nutrients such as phosphorus and nitrogen to receiving waters can over-stimulate the growth of aquatic plants to the detriment of other aquatic life and some beneficial uses of the receiving water. Nutrients generally have more adverse effects in water bodies with slow flushing rates, such as slow moving streams and lakes. Also, nutrients attached to suspended solids in stormwater runoff can cause problems where they settle out downstream.

Sources of phosphorus that may be present in highway runoff include tree leaves, surfactants and emulsifiers, and natural sources such as the mineralized organic matter in soils. Phosphorus may be present in stormwater discharges as dissolved or particulate orthophosphate, polyphosphate, or organic phosphorous.

Potential sources of nitrogen in highway runoff include atmospheric fallout, nitrite discharges from automobile exhausts, fertilizer runoff, and natural sources such as mineralized soil organic matter. Nitrogen may be present in stormwater discharges as nitrate, nitrite, ammonia/ammonium, or organic nitrogen.

Nutrients is a general pollutant category that covers a number of different elemental chemical forms, some of which require different BMP strategies. For example, Total Phosphorous can be controlled through pollution prevention and sediment control BMPs. Other types N in Nitrate form (NO_2) require source control as they are highly mobile in ground water and difficult to remove in storm water. Total Nutrients can be removed using Caltrans approved Treatment BMPs. Dissolved nutrients can be removed, but not as effectively as the total forms of nutrients. To select the most appropriate Treatment BMP, follow the T-1 Checklist process to select the most effective BMP based on the POC.

3.2.5.3 Pesticides (incl. Herbicides)

A pesticide is a chemical agent designed to control pest organisms. The most common forms of pesticides are organic chemicals designed to target insects (insecticides) or vascular plants (herbicides). Pesticides have been repeatedly detected in surface waters and precipitation in the United States. The main transport mechanism for these pollutants is through fine sediment. Once the contaminated fine sediment enters the water body, pesticides are transported from targeted applications to other parts of the environment. As the use of pesticides has increased, concerns about the potential adverse effects of pesticides on the environment and human health have also increased. The Department does not use diazinon or Dichlorodiphenyltrichloroethane (DDT).

Pesticides (e.g., organochlorides) are addressed by controlling erosion and sediment discharges. When treatment is required in these TMDL areas, use sediment as the POC and follow Matrix A for general purpose pollutant removal.

3.2.5.4 Metals (Particulate and Dissolved)

Metals in stormwater runoff may be in a dissolved phase or a particulate form adsorbed to suspended solids. Some Treatment BMPs are effective for removing specific particulate metals, but not for removing dissolved metals.

Possible sources of metals in highway runoff include the combustion products from fossil fuels (e.g., lead), the wearing of brake pads (e.g., copper (total and dissolved), cadmium), galvanized materials

(e.g., zinc), and the corrosion of metals, paints (e.g., silver, lead, chromium, zinc). Metals can also reach receiving waters through the natural weathering of rock and soil erosion.

Metals are addressed by controlling erosion and sediment discharge. When treatment is required, follow the T-1 process to select the most effective BMP based on the POC.

3.2.5.5 Pathogens and Bacteria

Pathogenic microorganisms including viruses, bacteria, protozoa, and helminth worms are of concern in urban stormwater runoff. The direct measurement of specific pathogens in water is extremely difficult. For that reason, the coliform group of organisms is commonly used as an indicator of the potential presence of pathogens of fecal origin.

Receiving waters are often adversely affected by stormwater runoff, dry-weather runoff, onsite wastewater, and animal wastes which may contain bacteria. Sources of total and fecal coliforms in stormwater runoff are ubiquitous (e.g., soil particles, droppings of wild and domestic animals). Human sources could include illegal sewer connections, seepage from septic tanks, homeless encampments, and illegal dumping into stormwater systems by Recreational Vehicles, garbage trucks, etc.

Bacteria are first addressed by controlling non-stormwater runoff. When treatment is required, follow Matrix A for general purpose pollutant removal.

3.2.5.6 Litter/Trash

Trash in stormwater is defined as manufactured objects made from paper, plastic, cardboard, glass, metal, etc. This definition excludes sediments, oil and grease, and vegetation. Trash is quantified by 24-hour air-dried volume and weight measurements. Trash within stormwater is considered to be a significant problem in highly urbanized areas, such as Los Angeles and Ventura Counties, and the San Francisco Bay Area. Trash in surface waters can inhibit the growth of aquatic vegetation, harm aquatic organisms by ingestion or entanglement, convey other pollutants, such as toxic substances, and cause aesthetic problems on shorelines.

Trash can be addressed using a full capture system such as Gross Solids Removal Devices (GSRDs). Institutional controls such as, street sweeping, and anti-litter education and outreach programs may also be implemented.

3.2.5.7 Biochemical Oxygen Demand

According to American Public Health Association (APHA) Standard Methods, “The Biochemical Oxygen Demand (BOD) is an empirical test in which standardized laboratory procedures are used to determine the relative oxygen requirements of wastewaters, effluents, and polluted waters. The test measures the molecular oxygen utilized during a specified incubation period for the biochemical degradation of organic material (carbonaceous demand) and the oxygen used to oxidize inorganic material”. BOD concentrations are usually measured and regulated as BOD5 or Ultimate BOD, milligrams per liter (mg/L) as defined by the standard EPA methods and used as regulatory compliance in NPDES permits. High BOD values which are usually the result of organic contamination in discharges (e.g., stockpiles of vegetation and animal carcass, pump stations, fertilizers, waste water) can deplete the dissolved oxygen levels in receiving waters and therefore can

negatively affect the beneficial uses. BOD is the first conventional pollutant listed in the CWA and referenced in many permits Caltrans receives. When treatment is required, follow Matrix A for general purpose pollutant removal.

3.2.5.8 Turbidity

Turbidity is the measure of water clarity, measured as the amount of light that is scattered and absorbed rather than transmitted. “Turbidity in water is caused by suspended and colloidal matter such as clay, silt, finely divided organic and inorganic matter, and plankton and other microscopic organisms” (APHA Standard Methods), usually shown as nephelometric turbidity units (NTU). Turbid waters are indicators that pollutants are present, as such, turbidity is a common monitoring requirement of NPDES permits to determine compliance, usually in relation to background levels.

Turbidity is best addressed by controlling sources of sediment through erosion and sediment discharge. When treatment is required, follow the T-1 process to select the most effective BMP based on Sediment as the POC.

3.2.5.9 Temperature

Water temperature can be negatively influenced by changes to riparian habitat resulting in reduced shade coverage and flow conditions of streams. When water temperature is elevated 5-degrees F beyond natural receiving water temperature, then thermal pollution is considered to have occurred. Temperature changes can be due to reductions in stream base flow (esp. reduction in groundwater contribution), contributions of non-stormwater sources, and channel geometry (i.e., flow spread resulting in thin depth). The removal of riparian vegetation and increased sedimentation can be a cause of temperature changes, especially in streams and creeks; however, rivers and larger waters are usually affected by point sources, such as discharges of cooling water from industrial operations.

While Caltrans is commonly listed in temperature TMDLs, the major causes of the impairment are non-point sources such as losses of riparian vegetation and land use changes throughout the watershed. Caltrans generally has limited control of these causes. One commonly listed contributor to temperature impairment is increased sedimentation which can be caused by widening of channels and decreased stream depth which, in most cases, Caltrans is a minor contributor. When treatment is required, follow Matrix A for general purpose pollutant removal.

3.2.5.10 Mercury

Past mining practices, notably during the “California Gold Rush,” used mercury to increase gold recovery. Mercury was widely used in hydraulic gold mining and other mining operations; consequently, mercury is found in sediments near and within aquatic environments from this past practice or from naturally occurring mercury. Elevated mercury, in the form of methylmercury, within receiving waters can lead to increased bioaccumulation of mercury in fish and other aquatic organisms. When humans and predators repeatedly consume fish with elevated mercury, then toxicity risks leading to health impacts or mortality can occur. Methylmercury formation in aquatic systems is usually caused by bacteria that thrive in low oxygen conditions. Streams or wetland sediments containing elemental mercury can undergo increased methylation when waters are stagnant or low in oxygen, especially over lengthy periods of time. The bacteria carrying methylmercury are consumed by plankton and macroinvertebrates, which are then consumed by fish

and then ultimately predators and humans at the top of the food chain, which can increase the concentration through bioaccumulation.

For naturally occurring mercury, the impairment is commonly connected to increased sedimentation and turbidity therefore mercury can be addressed by controlling erosion and sediment discharge. Mercury is also commonly found in stream sediments, where avoiding the disturbance of stream sediments is usually the most effective BMP. When mercury is the POC, use the T-1 Checklist and select Treatment BMPs that are effective at removing sediment and TSS. However, there are specific notations in the T-1 Checklist that require the avoidance of certain BMPs that may create conditions leading to the methylation of mercury. (e.g., Delaware Media Filters, Multi-Chamber Treatment Train (MCTT), or other Treatment Best Management Practices (TBMPs) with permanent pools of water that can be anaerobic).

3.2.5.11 Polychlorinated Biphenyl (PCB)

Polychlorinated biphenyl (PCB) is a synthetic organic chemical compound of chlorine attached to biphenyl. PCBs which were widely used as dielectric and coolant fluids in transformers, cutting fluids for machining operations, carbonless copy paper, heat transfer fluids, and other industrial uses. Due to PCBs' environmental toxicity and classification as a persistent organic pollutant, PCB production was banned by the United States Congress in 1979. PCBs are persistent in the environment and may be encountered from historic uses.

Pollution prevention through sediment and erosion control at the source is the most effective BMPs. When treatment is required, follow Matrix A for general purpose pollutant removal.

3.3 BEST MANAGEMENT PRACTICES

As used in this document, the term best management practice (BMP) refers to operational activities or physical devices that control, prevent, remove, or reduce pollution and minimize potential impacts upon receiving waters. Accordingly, the term BMP refers to both structural and nonstructural controls that have direct effects on the release, transport, or discharge of pollutants.

Throughout the project development process, the PE is to incorporate BMPs to address impacts to stormwater quality and to fulfill permit requirements. One strategy referenced in the Caltrans Permit is low impact development (LID). LID is a stormwater management strategy with a goal of maintaining or restoring the natural hydrologic functions of a site to achieve natural resource protection objectives. LID employs a variety of natural and engineered BMPs that reduce the rate of runoff, filter pollutants out of runoff, and facilitate the infiltration of water into the ground. Caltrans prioritizes the use of these types of BMPs in the Treatment BMP consideration process (see Checklist T-1, Part 1 in Appendix E).

The Caltrans SWMP identifies permanent and temporary BMPs that have been approved for statewide application and must be considered throughout the planning and project development process. Four categories of BMPs (DPP, Treatment, Construction Site, and Maintenance) are described in Table 3-2.

Table 3 2. BMP Categories, Descriptions and Responsible Divisions

BMP	Description	Responsible Division for BMP Implementation
Design Pollution Prevention (DPP) BMPs	Permanent soil stabilization and concentrated flow controls and slope protection systems, etc.	Design, Construction, and Maintenance
Treatment BMPs	Permanent treatment devices and facilities	Design, Construction, and Maintenance
Construction Site BMPs	Temporary soil stabilization and sediment control, non-stormwater management, waste management, etc.	Design and Construction
Maintenance BMPs	Litter pickup, drainage cleaning, street sweeping, etc.	Maintenance

DPP BMPs are source control BMPs used to prevent pollutants from entering stormwater. In addition, some DPPs have infiltration capabilities that can be applied towards treatment requirements. Treatment BMPs are used to remove pollutants from stormwater prior to discharge off-site. Construction Site BMPs are used to reduce pollutants from stormwater discharges as a result of construction activities. Maintenance BMPs are used to reduce pollutant discharges during highway maintenance and activities at maintenance facilities.

DPP BMPs and Treatment BMPs together form the permanent BMP strategy for projects. The permanent BMP strategy should be selected and designed to minimize project life-cycle maintenance costs and resources, while providing adequate site access and maximizing maintenance and worker safety. Construction Site BMPs form the temporary BMP strategy for projects. Both DPP and Construction Site BMPs must be considered for every project. If the project site is subject to stormwater run-on flows from off-site sources, appropriate control measures must be implemented to convey the flows around or through the site. Construction Site BMPs should consider staging and other aspects of construction activities when developing the temporary BMP strategy for the project. Consideration for the implementation of permanent and temporary BMPs must begin in the planning process, and continue through the project development process.

DPP BMPs, Treatment BMPs, and Construction Site BMPs are discussed in further detail in the following sub-sections and Appendices A through C of this document.

In addition to the above BMP categories, the PE must also be aware of, and address, non-stormwater discharges associated with a project, such as pumping stations, tunnel washing, etc. The PE should coordinate with the District/Regional NPDES Coordinator if non-stormwater or other waste discharges are present and persistent.

When estimating the project planning costs, if BMPs are not eliminated from consideration due to siting or feasibility criteria, then the BMPs should be fully considered and documented in the SWDR. This practice ensures that adequate costs are projected and enough funding is allocated to allow detailed design and construction of these BMPs.

3.3.1 Design Pollution Prevention (DPP) Best Management Practices

The DPP BMPs are permanent measures to reduce pollution discharges (e.g., reduce erosion, manage non-stormwater discharges) after construction is completed. DPP BMPs are used as a strategy to minimize runoff, maximize infiltration, maximize vegetation depending on location, and reduce erosion.

The DPP BMPs that are to be incorporated, as appropriate, into the design of new facilities and reconstruction or expansion of existing facilities are listed in Table 3-3. Design guidelines for Design Pollution Prevention BMPs are included in Section 5 and Appendix A.

Table 3.3. Design Pollution Prevention (DPP) BMPs
Consideration of Downstream Effects Related to Potentially Increased Flow
Peak Flow Attenuation Devices
Reduction of Paved Surface (i.e., increase pervious area)
Soil Modification
Energy Dissipation Devices
Preservation of Existing Vegetation ¹
Concentrated Flow Conveyance Systems
Ditches, Berms, Dikes and Swales
Overside Drains, Downdrains, Paved Spillways
Channel Linings
Flared Culvert End Sections
Outlet Protection/Velocity Dissipation Devices
Slope/Surface Protection Systems
Vegetated Surfaces
Benching/Terracing, Slope Rounding, Reduce Gradients
Hard Surfaces

¹For all Caltrans projects, Caltrans will maximize vegetation-covered soil areas of a project.

3.3.2 Treatment Best Management Practices

Treatment BMPs are permanent measures to improve stormwater quality after construction is completed. The BMPs listed in Table 3-4 are Caltrans approved Treatment BMPs. A strategy of BMP deployment has been developed to best meet water quality objectives using a prioritization process. Refer to Section 5 and the Checklist T-1, Part 1 for further information.

Table 3 4. Approved Treatment BMPs
Biofiltration Systems
Design Pollution Prevention (DPP) Infiltration Areas
Infiltration Devices
Detention Devices
Traction Sand Traps
Dry Weather Flow Diversion
Gross Solids Removal Devices (GSRDs)
Media Filters
Multi-Chamber Treatment Train ¹
Wet Basins ¹
Bioretention
Open Graded Friction Course ²

PEs are encouraged to consider combining approved BMPs as part of a treatment train to meet post-construction treatment requirements.

3.3.3 Construction Site Best Management Practices

Construction Site BMPs (also sometimes called temporary BMPs) are deployed during construction activities to reduce pollutants in stormwater discharges during construction. Table C-1 in Appendix C is a matrix of approved Construction Site BMPs that are consistent with the BMPs and control practices required under the CGP and the *Statewide Stormwater Management Plan (SWMP)*. The Department's Construction Site BMPs are divided into six categories as shown in Table 3-5:

Table 3 5. Approved Construction Site BMP Categories
Temporary Soil Stabilization
Temporary Sediment Control
Wind Erosion Control
Tracking Control
Non-Stormwater Management
Waste Management and Materials Pollution Control

The strategy used for implementing Construction Site BMPs depends on specific project conditions, anticipated construction operations, and staging. The level of detail and coordination in support of

¹ Caltrans has found that other approved Treatment BMPs are equally effective and more sustainable due to lower life cycle costs and maintainability than MCTT and Wet Basins.

² Tentative approval June 2017.

the estimate is different at each phase of the project. Construction Site BMPs are temporary and are expected to be removed at the end of the project.

In order to provide information for contractors to both bid on projects and prepare the SWPPP/Water Pollution Control Program (WPCP), the design staff must supply certain water quality-related information in the project PS&E. Construction Site BMPs are deployed per an approved SWPPP or WPCP prepared by the contractor during the construction phase of a project.

During the design and planning phases of a project, the PE must develop a BMP strategy and coordinate with the Department's Construction Division and the District/Regional Design Stormwater Coordinator to determine specifications, details, and perhaps supporting plan sheets that support an estimate of the types, locations, and quantities of potential Construction Site BMPs that are likely to be deployed by the contractor. The PE must also prepare a corresponding construction cost estimate (not supplied to contractors) to ensure that sufficient construction funds are programmed for potential BMPs and supplemental activities.

Additional information on design, placement, and applicability of Construction Site BMPs can also be found in Appendix C of this document, or in the *Construction Site BMP Manual*.

3.3.4 Maintenance Best Management Practices

Maintenance BMPs are water quality controls used to reduce pollutant discharges during highway maintenance and activities conducted at maintenance facilities. The Maintenance BMPs are organized by family types based on long-standing protocols in the Maintenance Manual. Families are designated by alphabet characterizations that range from the A Family -Flexible Pavements to the T Family - Management and Support.

The PE is to collaborate with Maintenance on improvements within the project limits that support Maintenance BMPs. Many of these improvements conducive for Maintenance BMPs might also be considered DPP BMPs. One example of a Maintenance BMP is the Department's practice of stenciling messages at storm drain inlets accessible to pedestrian and bicycle traffic, including highway facilities such as park and ride lots, rest areas and vista points to assist in educating the public about stormwater runoff pollution. PEs should contact the District Maintenance Stormwater Coordinator to identify stencil types, specifications, and details for projects falling within these areas.

Other BMPs exist, but are installed based on public need or at the request of the Maintenance Area Manager in line with the project scope and budget. These BMPs might include the installation of call boxes, anti-littering signage or measures, stabilized access points, vehicle pullouts, temporary material and waste storage locations, etc.

THIS PAGE INTENTIONALLY LEFT BLANK.

4 Treatment Consideration

4.1 Introduction

This section provides Project Engineers (PEs) with guidance on the process and procedures to determine the need for incorporating stormwater Treatment Best Management Practices (BMPs) into a project. This section defines the project impervious areas and describes how to consider them when determining if treatment is required. In addition, this section explains how to document the project pervious and impervious areas that may be used for post construction treatment, Alternative Compliance, or Total Maximum Daily Load (TMDL) Compliance Units (CU), as determined by the District/Regional National Pollutant Discharge Elimination System (NPDES) Coordinator.

4.2 Treatment Objectives

The Department has two treatment objectives as follows:

Objective #1 - Achieve permit compliance by addressing post construction stormwater treatment.

Post construction stormwater treatment is based on new and replaced impervious surfaces¹ within a project, but is only required when a specific impervious threshold for considering Treatment BMPs has been met. This determination begins by following the procedure described in Section 4.3.

Objective #2 - Generate Compliance Units for achieving Total Maximum Daily Loads. Projects located in TMDL watersheds, where Caltrans is a named stakeholder, can potentially generate CUs to assist in meeting obligations of TMDLs. CUs are determined by treating: 1) runoff from impervious areas in excess of that computed and assigned under Objective #1 and 2) runoff from pervious areas. CUs can also be generated by stabilizing pervious surfaces to prevent soil loss where the pervious area does not already treat upstream impervious areas. Section 4.6 provides additional detail on CUs for TMDLs. CUs from multiple projects and other activities are used collectively towards TMDL compliance on a statewide basis.

4.3 Project Evaluation Process

The steps described below correspond to the steps shown in Figure 4-1.

Step 1 - Start

The PE should use Figure 4-1, the guidance provided in this section, and the Evaluation Documentation Form (EDF) in Appendix E to determine if a specific project requires the consideration of permanent Treatment BMPs.

¹ Applicable for projects with an approved PID dated on or after July 1, 2013.

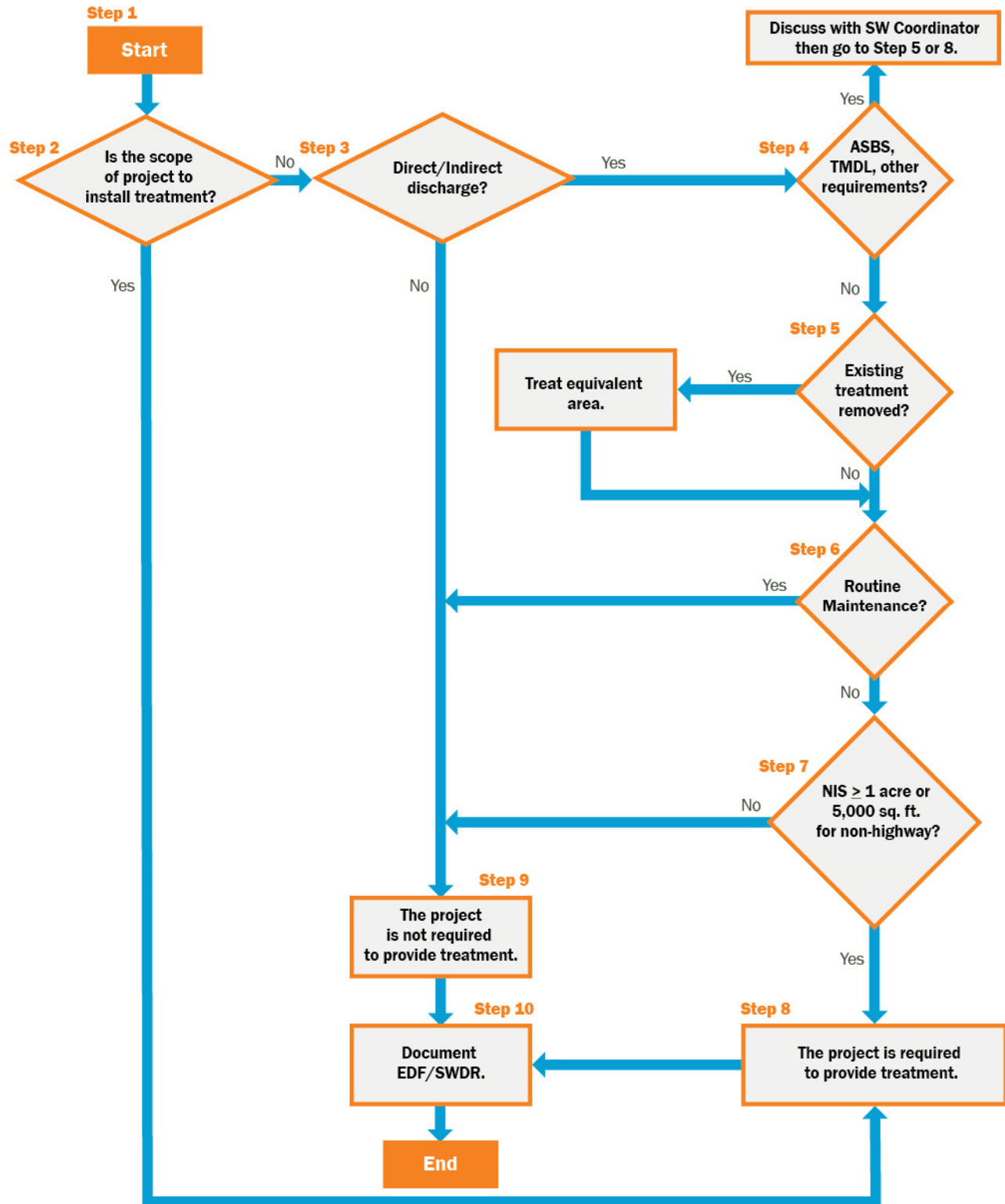

Figure 4-1. Project Evaluation Process for Consideration of Permanent Treatment BMPs

Step 2 - Is the scope of the project to install Treatment BMPs?

Certain Departmental projects have primary scope to install Treatment BMPs for Alternative Compliance or CUs. Projects such as these are not required to evaluate the need for inclusion of treatment. Most projects will answer “No” to this step.

Step 3 – Does the project directly or indirectly discharge to Surface Waters?

Surface Waters are known as Waters of the United States and/or Waters of the State. In general, these include creeks, streams, rivers, oceans, reservoirs, wetlands, estuaries, and lakes.

A direct discharge means that surface runoff directly enters the surface water body without first flowing through a municipal separate storm sewer system (MS4). An indirect discharge means that runoff to the surface water body travels through an MS4 stormwater conveyance system or unlisted tributary before reaching the surface water.

Contact the District/Regional Design Stormwater Coordinator for scenarios of when runoff would not be considered as directly or indirectly discharging.

If a project directly or indirectly discharges to surface waters, the PE should continue to Step 4. If not, the project is not required to consider the incorporation of Treatment BMPs and the PE should prepare the appropriate documentation to be attached to the Stormwater Data Report (SWDR). Most all projects will answer “Yes” to this step.

Step 4 – Does the project discharge to Areas of Special Biological Significance (ASBS) or a Total Maximum Daily Load (TMDL) watershed, or have other documented pollution control requirements?

All projects that discharge into a receiving water having a designation of ASBS or are subject to other pollution control requirements may need to consider Treatment BMPs. Projects or portions of a project within a TMDL watershed where Caltrans is a named stakeholder are to be evaluated to identify potential Compliance Unit Credits (CU) from Treatment BMPs based upon PDT advice and project sponsor determination. Information on ASBS and TMDLs should be included in the Water Quality Assessment Report (WQAR) or equivalent document.

Step 5 – Are any existing Treatment BMPs partially or completely removed?

The Department has implemented treatment of stormwater within its RW since the early 1990s. These features may not be readily apparent in the field, so as-built plans should be reviewed to identify existing Treatment BMPs. District databases maintained by the District/Regional Design Stormwater Coordinator and District Maintenance Stormwater Coordinator may also identify these locations when as-built plans are not sufficient.

If an existing Treatment BMP is removed or modified by the project, or if any portion of its impervious or pervious contributing drainage area (CDA) cannot continue to be treated by the existing Treatment BMP, then the project shall, at a minimum, treat an equivalent area. See Section 4.4.1, Condition 1.

Step 6 – Is the scope of the project routine maintenance?

Projects that maintain the original line and grade, hydraulic capacity, or original purpose of the facility are considered routine maintenance projects and are not required to consider Treatment BMPs. Examples of routine maintenance activities include:

- Overlaying a roadway surface, including overlay on top of existing shoulder backing if the shoulder backing is not removed to erodible surface during placement;
- Replacing a roadway surface without exposing the underlying soil or pervious subgrade;
- Re-grading a ditch to the original line and grade;
- Planting and irrigation system installations and upgrades;
- Vegetation removal with planned vegetation re-establishment;
- Culvert lining; or
- Replacing a culvert in-kind.

Changes to line, grade or hydraulic capacity include any changes made within the project limits that would alter the hydrologic/hydraulic behavior of stormwater discharges. The following changes would be considered a change in line, grade or hydraulic capacity:

- A change in the time of concentration, peak flow, volume or velocity of stormwater discharges;
- Modifying or creating new drainage ditches, swales, culverts, or storm drain facilities; or
- Changing historic drainage patterns.

Modifying drainage ditches, swales, culverts, or storm drain facilities does not include repairs or grading to re-establish the original line, grade or hydraulic capacity of a ditch or swale, nor does it include minor improvements such as adding culvert flared end sections, energy dissipation, or replacing pipe sections "in-kind."

Step 7 – Does the project result in an increase of one acre or more of new impervious surface (NIS)?

Determine NIS: The new impervious surface (NIS) is the addition of the net new impervious (NNI) and the replaced impervious surface (RIS):

$$NIS = NNI + RIS$$

The NNI is the total post-project impervious area minus the pre-project impervious area. Any new impervious area in a project on land that was previously pervious should be included in the calculation of NNI; this includes surfaces attributed to roadway, maintenance vehicle pullouts, and other hard surfaces.

RIS is generated when the underlying soil or pervious subgrade is exposed during roadway construction. This would only occur when the entire roadway structural section (i.e., surface course and base course) is replaced. Roadway surfaces are commonly replaced, but usually only to a portion of the roadway structural section, such as in grooving and grinding a roadway surface to then place a "lift" or layer of new pavement surface. Because the pervious subgrade is not exposed, this would not be considered RIS.

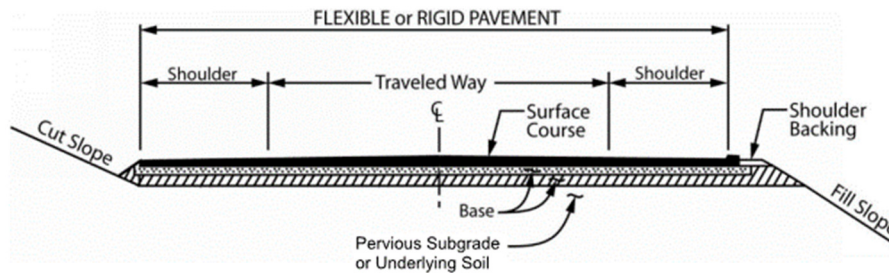

Figure 4-2. Basic Roadway Pavement Layers

The Caltrans Permit allows reductions to the NIS. Use Table 4-1 Excluded Impervious Areas to reduce the NNI and RIS.

Table 4 1. Excluded Impervious Areas

Areas to subtract from NNI:

- Replaced surfaces to support the installation or relocation of utilities and pipelines;
- The area of intersection of new bridges over impervious area;
- Surfaces within tunnels and tube structures;
- Sidewalks (including Class 1 bike paths);
- Pedestrian ramps;
- Bike lanes on existing roadways (Class I, II, and III Bikeways only); and
- Impervious portions of the DPP and Treatment BMP footprint (e.g., slope paving, lined ditches, GSRDs).

Areas to subtract from RIS:

- Replaced surfaces that drain to an existing Treatment BMP that will be protected and perpetuated.

Does NIS equal one acre or more?

If the project meets the threshold treatment requirement of one acre or more (5,000 ft² for non-highway projects) of NIS, then treatment is required. There may be other impervious areas of the project that need to be considered for treatment based on the project NNI. This additional area is described in Section 4.4.1.

Steps 8, 9, and 10 – Document for Project Files by Completing EDF and SWDR.

All supporting data used to determine whether a project must implement Treatment BMPs should be summarized for inclusion in the Project Files. A copy of the initialed EDF is a required attachment of the SWDR at all phases.

4.4 Treatment Areas

The determination and calculation of surface areas, both impervious and pervious, is essential in the implementation of Treatment BMPs either directly within the project or through an alternative compliance strategy (Section 4.5). The calculation of surface area within a project is not difficult; however, understanding how various surfaces are defined, calculated, and applied towards various

permit conditions can be complex. The project post construction treatment requirement can be summarized by the following equation:

$$\text{Post Construction Treatment Area (PCTA)} = \text{NIS} + \text{ATA (Condition 1 Impervious and Condition 2)}$$

The NIS was defined in Step 7 of Section 4.3; it is a fixed area calculation. The Additional Treated Area (ATA) is an area calculation that is to be treated based on the applicability of site conditions further detailed in Section 4.4.1. Conditions 1 and 2 are applicable to the PCTA. The total area to be treated by project Treatment BMPs can be summarized by the following equation:

$$\text{Total Area to be Treated} = \text{NIS} + \text{ATA (Conditions 1 and 2)} + \text{TMDL CU and/or Alternative Compliance}$$

In this equation, the TMDL Compliance Units or the Alternative Compliance for post construction are areas treated in addition to the post construction requirements of the NPDES permit.

Waivers: Districts may submit a Treatment BMP Exemption Memorandum to the Regional Water Board Executive Officer for consideration when a project will have a minimal impact on water quality. The Regional Water Board Executive Officer may waive the treatment control requirements, or lessen the stringency of the requirements. Consult your District/Regional NPDES Coordinator for District procedures and appropriate use.

4.4.1 Additional Treated Area (ATA)

In Section 4.3, Step 7, when NIS equals or exceeds the threshold requirement of one acre or more (5,000 ft² on non-highway projects), it meets the post-construction treatment requirement. When project circumstances require treatment beyond the NIS, then this additional area is referred to as ATA. The ATA is determined by evaluation of the following conditions:

Condition 1 - If an existing Treatment BMP is removed, then add that area to the projects required treatment areas PCTA or TMDL CU.

Condition 2 - When the NNI for the project is greater than 50 percent of the total post-project impervious area within the project limits the entire impervious area shall be included in the PCTA. In order to make this determination, divide the NNI by the total post-project impervious area. (Note: Where the NNI is less than or equal to 50 percent of the total post-project impervious area within the project limits, then no additional impervious area is required to be treated.)

In addition to PCTA and ATA described above, there are opportunities where impervious and pervious surfaces are treated by the project either in excess of the treatment requirement or where post construction treatment is not required.

After the PCTA has been addressed, then any remaining area treated by the project is applied towards TMDL CU or alternative compliance.

1. Impervious area that is accounted for during the sizing of the Treatment BMP, and was not an area used to address the PCTA or ATA Condition 1.
2. Pervious area that is accounted into the sizing of the Treatment BMP.

All of the treatment beyond PCTA should be documented as Alternative Compliance and/or CUs, as applicable. Treatment for compliance units should be considered, so that a project sponsor can purposely seize upon a treatment opportunity to generate Alternative Compliance and/or CUs. This strategy would typically be implemented when project features are conducive to installing Treatment BMPs and there are motivations to generate Alternative Compliance and/or CUs. The District/Regional NPDES Coordinator, in consultation with the PDT and project sponsor, is responsible for determining how the TMDL CU and or alternative compliance is tracked. The PE should coordinate with the District/Regional NPDES Coordinator on documentation.

4.4.2 Treatment Area Example

An example of a highway widening project which describes the process of evaluating treatment areas is provided below.

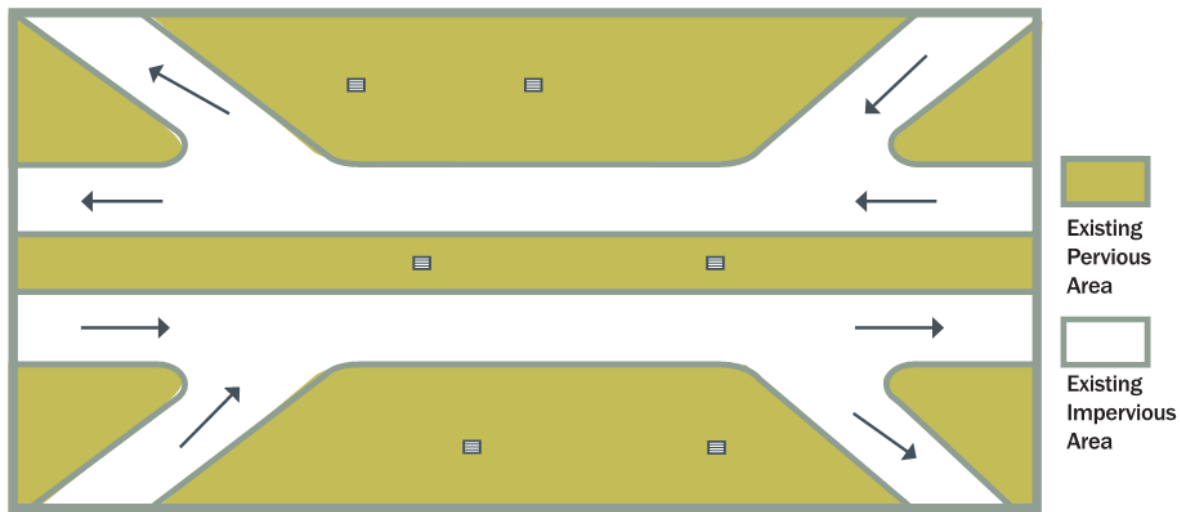

A) Pre-Project Condition

An existing 2-lane highway with a vegetated median and on-ramps and off-ramps; this diagram represents the project limits. The total pre-project impervious area is 5 acres (ac).

Total Pre Project Impervious Area = 5.0 ac

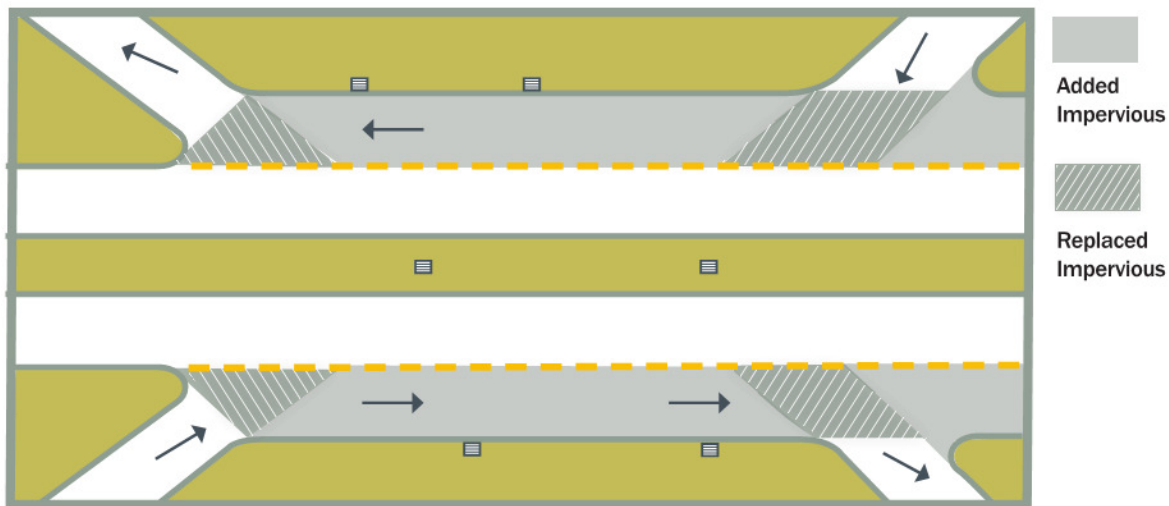

B) Post Project Condition – What is the NIS?

A new auxiliary lane is placed between both sets of ramps and extending to right. The added impervious area is 1.68 ac and the replaced impervious surface is 0.42 ac, thus NNI = 1.68 ac and RIS = 0.42 ac.

NIS = NNI+RIS = 1.68 ac + 0.42 ac = 2.1 ac

Treatment is required when NIS is greater than or equal to 1 acre therefore treatment is required.

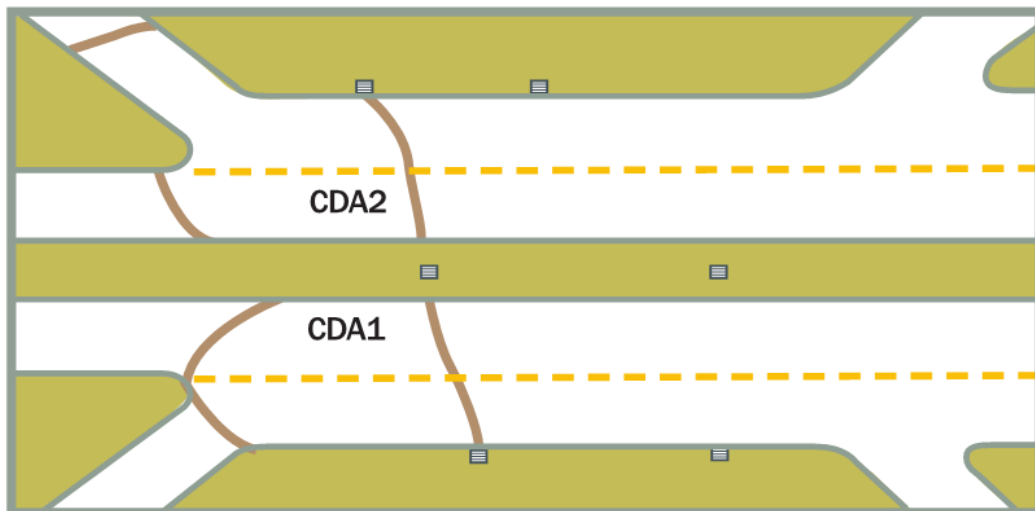

C) Post Project Condition – Determine the Post Construction Treatment Area and evaluate hydraulically connected impervious areas.

Evaluate project ATA per Section 4.4.1. There are no existing Treatment BMPs being removed as part of this project, thus ATA Condition 1 = 0 ac. When NNI is less than 50% of the total post-project impervious area (TPPIA), then the hydraulically connected impervious area does not need to be

treated. NNI is 25% of the total post-project impervious area thus, ATA Condition 2 = 0 ac.

$$\frac{\text{NNI}}{\text{TPPIA}} \times 100 = \frac{1.68 \text{ acres}}{(5.0 + 1.68) \text{ acres}} \times 100 = 25\%$$

If the NNI had been greater than or equal to 50% of the total post project impervious area (TPPIA), then ATA Condition 2 would apply.

In the project limits, the PE needs to find a CDA equal to the PCTA.

$$\text{PCTA} = \text{NIS} + \text{ATA (Condition 1 Impervious and Condition 2)} = 2.1 \text{ ac} + 0 \text{ ac} + 0 \text{ ac} = 2.1 \text{ ac}$$

Two CDAs are delineated by the PE that could satisfy the PCTA. CDA1 is the lower paved area consisting of 1.1 ac; CDA2 is the upper paved area consisting of 1.25 ac. CDA1 + CDA2 = 1.1 ac + 1.25 ac = 2.35 ac, which exceeds the amount of area needed to be treated. This excess treatment of 0.25 ac is not required to be treated even though it is hydraulically connected. As a result, the Treatment beyond PCTA 0.25 ac could be counted as TMDL CU.

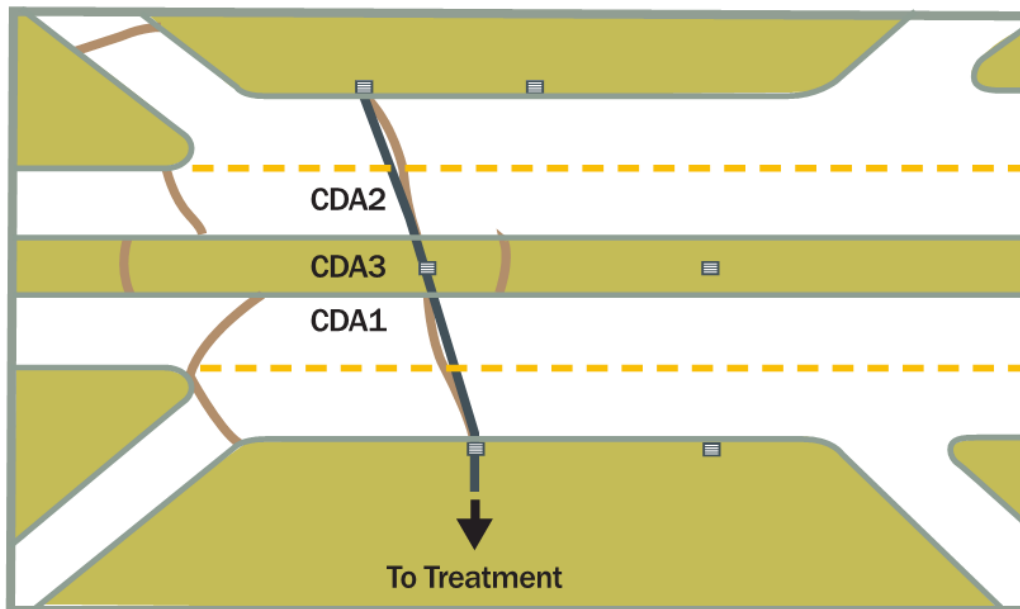

D) Post Project Condition – Evaluate hydraulically connected pervious areas.

A drainage system conveys runoff from CDA1 and CDA2, but also contains runoff from CDA3; an area of 0.8 ac. The discharge from this drainage system is planned for treatment in the project. Due to the hydraulic connectivity of CDA3, the PE accounts for treating the runoff from that area. Since runoff from CDA3 is pervious, it is not part of post construction requirement and may be documented as TMDL compliance units. Thus, TMDL CU equals 0.8 ac of CDA3 and the excess balance from CDA1 and CDA2 of 0.25 ac; TMDL CU = 0.8 ac (pervious) + 0.25 ac (impervious) = 1.05 ac.

$$\text{Total Impervious Treated} = \text{NIS} + \text{ATA} + \text{TMDL CU} = 2.1 \text{ ac} + 0 \text{ ac} + 0.25 \text{ ac} = 2.35 \text{ ac}$$

Total Pervious Treated = TMDL CU (pervious) = 0.8 ac

Total Area to be Treated = NIS + ATA + TMDL CU = 2.1 ac + 0 ac + 1.05 ac = 3.15 ac

E) Post Project Conditions Alternatives to utilize treatment credits

	CU	Alternative Compliance
Maximum CUs	1.05 ac.	0 ac.
Maximum Alternative Compliance	0.8 ac.	0.25 ac.

Maximum CU

here are a variety of combinations for potential Alternative Compliance and CUs available from the . The maximum eligible CUs = 0.80 ac (pervious) + 0.25 ac (impervious) = 1.05 ac. However, if the preference is to maximize Alternative Compliance, then only the impervious (0.25 ac) would apply. Total CUs and Alternative Compliance depends upon how the 1.05 ac of treatment are applied. See the table above for possible maximums.

4.5 Alternative Compliance

In some instances, it may not be practical or feasible to provide complete or partial implementation of treatment to address the PCTA or ATA Condition 1 of a project. When this occurs, the district shall prepare an alternative compliance proposal for approval by the Regional Water Board Executive Officer or his designee until such time a statewide process is approved by the Executive Officer of the State Water Board. The proposal shall include documentation supporting the determination of infeasibility. Options for an alternative compliance proposal could include the following:

1. Implementation of treatment as part of a later stand-alone project, especially if the current project is one of several contracts that are part of a larger parent project to be implemented through multiple contracts. A stand-alone project within the Caltrans RW could be developed to provide the treatment commitment of the original project. This alternative compliance proposal should first try to identify treatment opportunities that would benefit the same watershed area and receiving water identified for the original project (i.e., project with the treatment shortfall). Careful accounting of the total area to be treated for the follow-up project is required. The treatment could be within a traditional project, but it must first treat the post-construction treatment area before Alternative Compliance can be generated for the deficient project. The total area to be treated and the application of credits between the deficient project and the follow-up project should be clarified in the SWDR.
2. Utilization of Alternative Compliance generated during previous projects. To identify available Alternative Compliance, contact the District/Regional NPDES Coordinator.

3. Implementation of treatment outside the Department's RW is an option. This option is sought when no other feasible options within the Department RW can be achieved. Finding a municipal partner or other entity to coordinate with on site design, construction, and future maintenance and operation are essential in the approval of this option. This alternative compliance project should first try to identify treatment opportunities in the same watershed and receiving water as the original project.
4. Other options agreed upon between the district and the Regional Board.

The District/Regional NPDES Coordinator, in consultation with the PDT and project sponsor, is responsible for developing the Alternative Compliance strategy for the project. The PE should document Alternative Compliance strategies known at the time of signing the SWDR.

4.6 TMDL Watersheds and Compliance Units (CUs)

The Department faces challenges in generating Compliance Units (CUs) as part of achieving a TMDL compliance strategy. Any project within a designated TMDL watershed where Caltrans is a named stakeholder that provides treatment in excess of the NIS and ATA Condition 1 Impervious may generate CUs for the Department. "In consultation with the SWRCB, Caltrans uses the following four methods to achieve CUs:

1. Caltrans SHOPP Storm Water projects (storm water mitigation stand-alone projects).
2. Caltrans SHOPP Storm Water funding contribution only (FCO) projects, in partnership with locals.
3. Other SHOPP projects such as fish passage projects and projects that include post construction stormwater BMPs.
4. Other Non-SHOPP, Cooperative Implementation Agreements (CIAs) that provide funding for local agency projects."

The Caltrans State Highway System Management Plan, Stormwater, March 8 2017.

As previously described, the impervious areas eligible for CUs can also generate Alternative Compliance for future district projects as part of an alternative compliance strategy described in Section 4.5. Meet with the District/Regional NPDES Coordinator to decide whether these impervious areas will be documented as Alternative Compliance or CUs; the treated area cannot be double counted.

In addition to these areas, specific design measures not related to treatment, such as implementing Fish Passage remediation or using specific permanent erosion control to stabilize slopes or to correct problem slopes within a TMDL watershed may qualify for CU crediting. Fish passage, culvert, bridge, scour, or slope stabilization remediation projects that can improve water quality by stabilizing the bed, bank or equalizing sediment transport in a sediment impaired TMDL waterbody, may qualify for CUs. Discuss with the District/Regional NPDES Coordinator. Consultation and concurrence from the regional board at PID is recommended, so that both agencies can agree early on the fish passage design and credits. Other drainage projects should demonstrate a reduction in sediment to the TMDL, through calculations showing the water quality benefits and pollutant reduction.

If the project is potentially claiming CUs, then the SWDR will contain a general accounting of areas that can be used towards the generation of CUs by the project. The final accounting of the number of CUs that will be claimed on the project will be done through the HQ Division of Environmental Analysis (DEA) - Stormwater Program. Supporting documentation shall be preserved.

THIS PAGE INTENTIONALLY LEFT BLANK.

5 Permanent BMP Strategy

5.1 Introduction and Objectives

This section provides a consistent approach to protecting water quality on Caltrans projects by using site design techniques and implementing permanent treatment in accordance with permit requirements. A permanent Best Management Practice (BMP) strategy must consider BMPs to treat runoff and manage impervious and pervious areas within the project limits. For new development and redevelopment projects that are required to incorporate post construction Treatment BMPs, this section describes a design process that includes the use of both Design Pollution Prevention (DPP) and Treatment BMPs. A site may require that many BMPs be placed within the project limits and each BMP must be sized to treat flows from its contributing drainage area.

Projects within a Total Maximum Daily Load (TMDL) area must meet the post construction treatment requirements before Compliance Units (CUs) may be generated. The exception is when the project is being constructed solely to generate CUs.

Treatment provided for projects for either post construction or TMDL requirements must be documented in the Stormwater Data Report (SWDR). The objective of this section is to:

- **Maximize infiltration.** To meet the Caltrans Municipal Separate Storm Sewer System (MS4) Permit requirements, Project Engineers (PEs) should identify and design project features that promote infiltration. All projects with disturbed soil area, independent of location or treatment requirements, should consider maximizing infiltration of stormwater runoff. This can include using low impact site design principles and infiltration-type DPP BMPs during site development and design.
- **Prioritize Treatment BMPs.** The PE will plan and design Treatment BMPs following a prioritization process to ensure compliance with the Caltrans Permit requirements.
- **Provide detailed documentation of treatment.** PE will track specific BMP information for the purposes of reporting compliance, implementing asset management, and estimating for long term maintenance.

5.2 Site Design and Design Pollution Prevention (DPP) Best Management Practices

The PE shall incorporate Design Pollution Prevention (DPP) BMPs on all projects that create any amount of disturbed soil area. In some cases, these same DPP BMPs may be used for infiltration of the water quality volume (e.g., soil modification, vegetated surfaces, channel lining, rock slope protection) to meet treatment requirements or to generate Alternative Compliance or CUs. The following site design principles shall be incorporated as feasible for the project:

- Conserve natural areas, including existing trees, stream buffer areas, vegetation, and soils.
- Minimize the impervious footprint of the project.
- Minimize disturbances to natural drainages.
- Design pervious areas to effectively receive runoff from impervious areas, taking into consideration the pervious areas' soil conditions, slope, and other design factors.

- Implement landscape and soil-based BMPs such as amended soils and vegetated strips and swales where feasible.
- Use climate-appropriate landscaping that minimizes irrigation and runoff. This promotes surface infiltration and minimizes the use of pesticides and fertilizers.
- Design landscapes to comply with the California Department of Water Resources Model Water Efficient Landscape Ordinance (MWELo).
 - Guidance on water conservation and the MWELo is available at: <http://www.dot.ca.gov/design/lap/>

Any stabilized pervious area (new, modified, or existing) within the project limits that receives runoff from an impervious area and promotes infiltration of the runoff may be considered for designation as a DPP Infiltration Area. DPP Infiltration Areas are vegetated and non-vegetated areas that have been designed or evaluated for infiltration capabilities. These areas provide infiltration to meet post construction requirements or TMDL CUs.

The PE will consider incorporating the Caltrans approved DPP BMPs described in Appendix A and listed in Table 5-1, in conjunction with the site design principles listed above. The consideration process for DPP BMPs is included in Appendix A, Checklist DPP-1, Parts 1-5.

Table 5 1. Design Pollution Prevention BMPs
Consideration of Downstream Effects Related to Potentially Increased Flow
Peak Flow Attenuation Devices
Reduction of Paved Surface (i.e., increase pervious area)
Soil Modification
Energy Dissipation Devices
Preservation of Existing Vegetation
Concentrated Flow Conveyance Systems
Ditches, Berms, Dikes, and Swales
Overside Drains, Downdrains, Paved Spillways
Channel Linings
Flared Culvert End Sections
Outlet Protection/Velocity Dissipation Devices
Slope/Surface Protection Systems
Vegetated Surfaces
Benching/Terracing, Slope Rounding, Reduce Gradients
Hard Surfaces

A flow chart illustrating the DPP BMP selection process for projects is shown in Figure 5-1. The PE is to document all DPP BMPs incorporated into the project in the SWDR. The DPP BMPs shall be designed to follow Section 800 of the *Caltrans Highway Design Manual (HDM)*. The PE must evaluate the potential for channel/slope erosion and design the project to provide stable drainage systems for the expected design flows for the site. This provides both water quality protection and protection of the highway infrastructure, as sediment is stabilized and prevented from entering water ways.

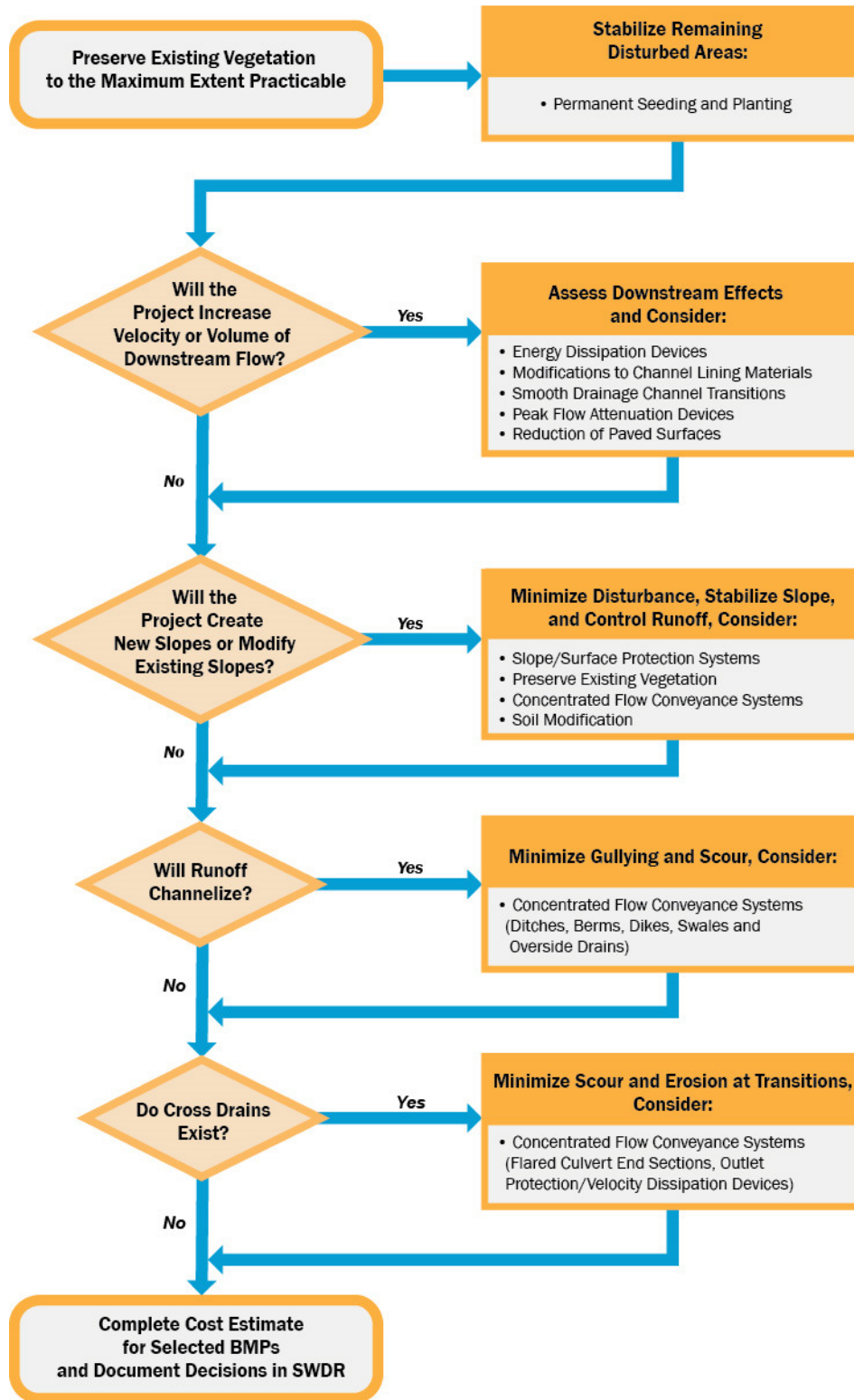

Figure 5-1. Decision Process for Selecting Design Pollution Prevention BMPs

5.2.1 Evaluation of Design Pollution Prevention (DPP) Infiltration Areas for Treatment

Existing and new DPP BMPs that infiltrate runoff (DPP Infiltration Areas) can be used to document treatment for that portion of the stormwater infiltrated. Existing conditions may provide some runoff infiltration that can be evaluated for infiltration treatment including vegetated and non-vegetated areas. All pervious areas may be designed to maximize infiltration, including the use of soil amendments or mulches. Refer to Appendix B.2 or the *Caltrans DPP Infiltration Area Design Guidance* for siting and design criteria.

If the project is required to provide post construction or TMDL treatment, the runoff infiltrated by each DPP BMP can be documented as treatment. If a project that is not required to provide post construction or TMDL treatment can infiltrate runoff, then Alternative Compliance or CUs can be documented. In this case, the PE should notify and coordinate with the District/Regional NPDES Coordinator to discuss the need to document Alternative Compliance or CUs. As an example of this scenario, Figure 5-2 below shows a widening project located within a TMDL area that does not trigger post construction treatment requirements. Since the roadway sheet flows onto an existing stabilized slope, the contributing drainage area draining to the slope may qualify for Alternative Compliance or CUs.

Typical Cross-Section through project area

Existing

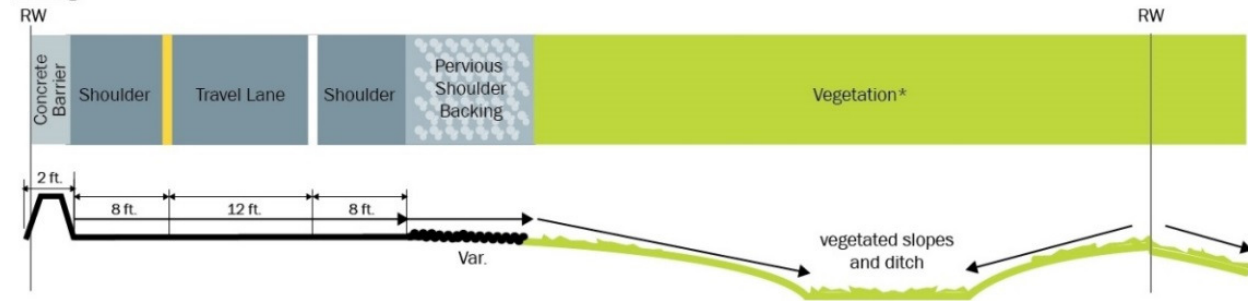

Proposed Widening

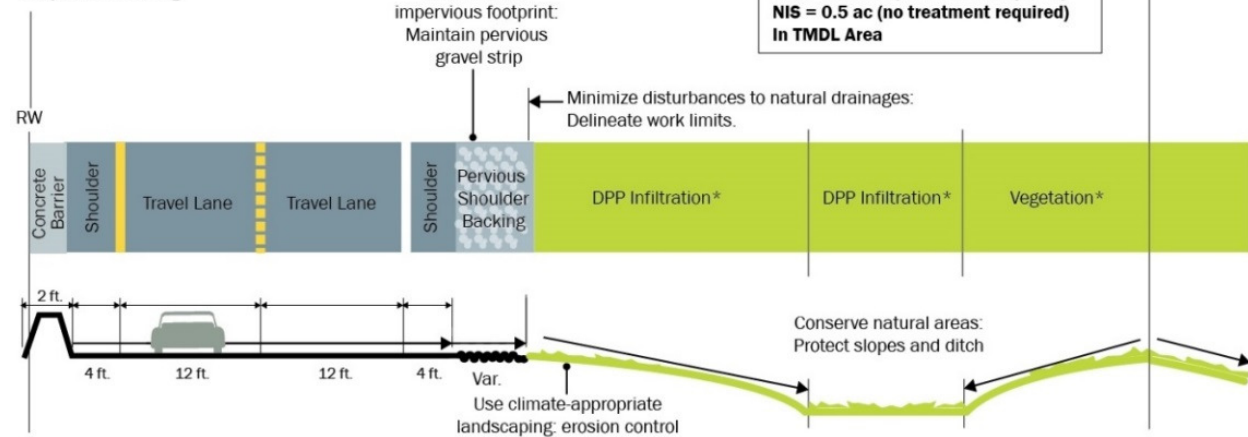

* Natural background conditions, which may include stabilized soils and other natural conditions.

Consider documentation of CUs or Alternative Compliance during design of required project DPP BMPs:

- Step 1. Evaluate existing infiltration rate of slopes and ditch areas, if infiltration is provided, delineate as a DPP Infiltration Area and use the Infiltration Tool to determine the WQV treated.
- Step 2. Quantify the impervious and pervious portions of the contributing drainage area that are being treated, including the percent WQV/WQF treated, and document in the project SWDR. Table E-2 can be used.

Figure 5-2. Highway Widening, Treatment Not Required

5.3 Treatment Best Management Practices Design Consideration

Treatment BMPs are used to treat runoff generated from the contributing drainage area. When a project is required to provide post construction treatment, the BMPs must treat an impervious area equal to the PCTA (see Section 4.4 for details on treatment areas). Treatment BMPs designed to meet the PCTA are to be considered according to the following priorities:

1. Infiltrate runoff from impervious surfaces equivalent to the PCTA, then
2. Treat excess runoff using LID based flow-through BMPs, then
3. Treat excess runoff using Caltrans approved, or pilot, Treatment BMPs, then
4. If 100 percent treatment of the runoff is not achieved, develop an alternative compliance strategy.

This process prioritizes landscape and soil-based BMPs and along with the Checklist T-1, Part 1, achieves permit requirements. Each BMP must be sized to treat the applicable stormwater runoff criteria as described in Section 5.3.3.

Figure 5-3 is an example describing an evaluation of the post construction treatment priorities for a road widening project. Since the roadway sheet flows onto an existing stabilized slope, the PE first treats the water quality volume (WQV) through infiltration on the existing slope and ditch (e.g., DPP Infiltration Area) before considering soil modification to improve infiltration. When 100 percent of the WQV is not infiltrated, other approved Treatment BMPs are evaluated.

Typical Cross-Section through project area

Existing

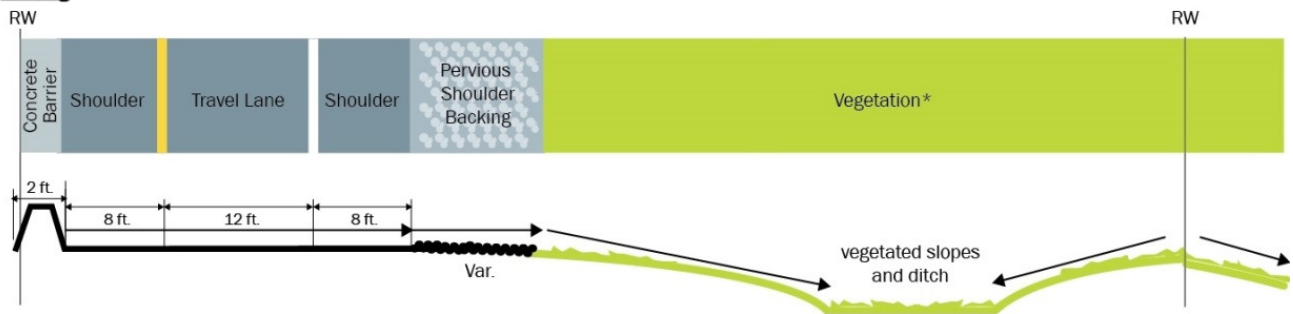

Proposed Widening

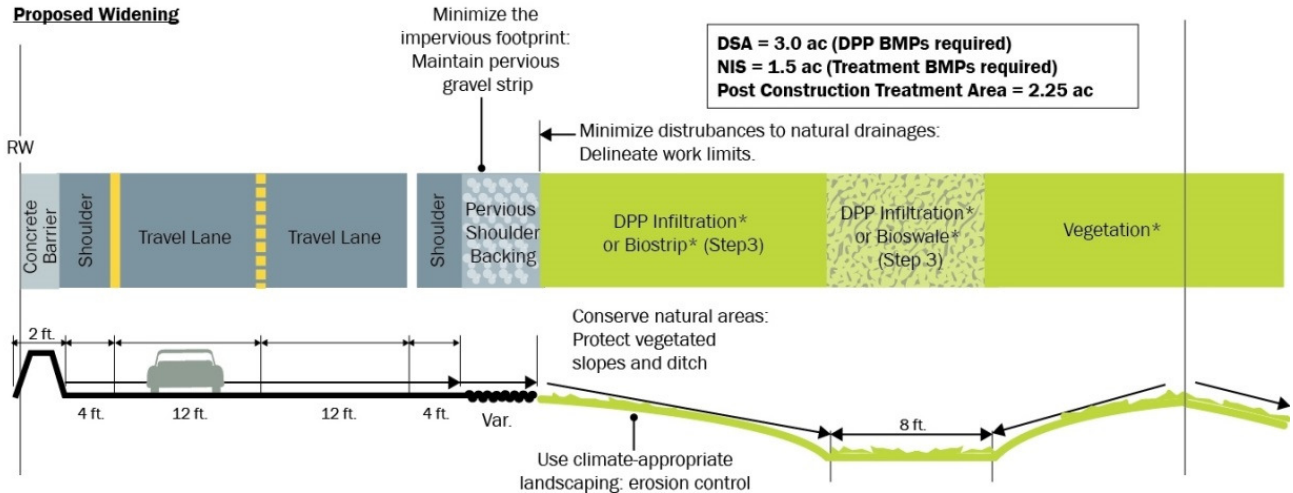

* Natural background conditions, which may include stabilized soils and other natural conditions.

Consider existing features as post-construction treatment during design of required project DPP and Treatment BMPs:

- Step 1. Calculate the WQV related to the PCTA.
- Step 2. Determine existing infiltration rate of DPP Infiltration Area, and use Infiltration Tool to determine the WQV infiltrated. If the WQV infiltrated is less than the WQV calculated in Step 1, consider amending the soils.
- Step 3. If WQV infiltrated by the DPP Infiltration Area is still less than WQV calculated in Step 1, then evaluate the existing conditions to determine if an infiltration device can be sited. If the area cannot meet the criteria for an infiltration type BMP, determine if the biostrip or bioswale design criteria can be met. Consider modifying the area to meet the criteria.
- Step 4. Quantify the impervious and pervious portions of the contributing drainage areas being treated. If the impervious portion is less than the PCTA, continue using Checklist T-1, Part 1 to consider other Treatment BMPs.
- Step 5. Document all areas treated by the project in the SWDR. Tables E-1 and E-2 or equivalent tables can be used.

Figure 5-3. Highway Widening, Treatment Required

When a project is being constructed solely to provide treatment to generate Alternative Compliance or CUs, the priorities above are still valid. PE is to use the Checklist T-1, Part 1 when designing Treatment BMPs for both post construction and TMDL compliance.

5.3.1 Site-Specific Determination of Feasibility

Several factors must be considered to determine which BMPs are suitable for a given application. Site-specific conditions can affect operations, maintenance, construction costs, safety, and aesthetics. General criteria used during the evaluation of Treatment BMPs include site specific determination of technical feasibility and legal and institutional constraints.

Technical Feasibility: Any BMP under consideration must be technically feasible. Caltrans must be able to implement the BMP within the context of the state highway system. Feasibility also includes health, safety, and maintainability concerns. BMPs that substantially increase the risk to Caltrans workers or the public are considered infeasible.

The feasibility of a BMP is assessed using the following process:

1. Determine whether the site characteristics, particularly the soil characteristics, are appropriate to support implementation of the BMP (checklists are provided in the appendices for this purpose);
2. Calculate the WQV or WQF that must be treated (See Section 5.3.3);
3. Configure the proposed BMPs needed to maximize the treatment of the WQV or WQF (this third step does not apply to Gross Solids Removal Devices (GSRDs) and Traction Sand Traps); and
4. Use Appendix B and design guidance to evaluate the proposed BMP, giving proper consideration to clear recovery zones, setbacks from structures, hydraulic head, and maintenance access roads and ramps.

During the planning and project development process, multiple project alternatives may be evaluated. If a project requires the consideration of Treatment BMPs and it is ultimately found not feasible to treat all of the PCTA within the project, then the PE shall discuss alternative compliance opportunities with the District/Regional NPDES Coordinator and document coordination, decisions made, and the date in the SWDR.

Sites requiring extraordinary plumbing to collect and treat runoff (e.g., jacking operations under a highway, bridge deck collection systems) may be considered infeasible due to their associated costs. Sites requiring extraordinary features or construction practices, such as retaining walls and shoring, may also be infeasible due to their associated costs relative to the cost of the BMP itself. The PE must use engineering judgment and collaborate with the PDT.

Legal and Institutional Constraints: The recommended BMP cannot compromise Caltrans compliance with other laws. For example, Caltrans must provide drainage under roadways to prevent water from accumulating up gradient and threatening the integrity of the roadbed and to limit encroachment of captured water on the traveled way. Caltrans cannot legally block historic drainage patterns or systems (e.g., runoff from farmland).

5.3.2 Treatment BMP Use and Placement Considerations

The physical dimensions of a BMP may have an important bearing on feasibility. The size of many BMPs is determined by the amount of runoff the system will be required to treat. The amount of runoff is affected by the location, land use, contributing drainage area, storm intensity, topography, and soil characteristics. For the design of Treatment BMPs, the district's hydraulics staff may need to be consulted.

Peak flow rates must be considered in the design of all highway drainage facilities including BMPs. The “Design Storm” is the particular event that generates runoff rates that the highway drainage facilities are designed to handle. Determining the “Design Storm” involves the selection of an appropriate design storm frequency for the specific project location under consideration. In order for a design frequency to be a meaningful criterion for roadway drainage design, it must be tied to an acceptable tolerance of flooding. Design water spread involving encroachment upon the roadbed or adjacent property determines the tolerance of flooding directly related to roadway drainage design. The HDM Chapter 831 provides a detailed discussion on how the probability of exceedance of the design storm and the acceptable tolerance to flooding depends on the importance of the highway and risks involved. For the purposes of this Project Planning and Design Guide (PPDG), the term “Design Storm” used in reference to designing drainage facilities will refer to the peak drainage facility design event as determined in accordance with the HDM.

5.3.3 Determining Water Quality Volume (WQV) and Water Quality Flows (WQF)

Unlike flood control measures that are typically designed to store or convey the peak volumes or flows of infrequent (i.e., return period typically > 5 years) storm events, Treatment BMPs are designed to treat the lower volume or flows associated with more frequent storm events (i.e., return period < 2 year). The volume or flows associated with the frequent events are commonly referred to as the WQV for BMPs designed based on volume, and WQF for BMPs designed based on flow. Treatment BMPs are sized to accommodate the WQF or WQV from the contributing drainage area. The contributing drainage area is the surface area that drains to the BMP; it can be comprised of both impervious and pervious surfaces. When the Treatment BMP cannot be sized to treat the entire WQV or WQF, then consider sizing the BMP to treat a portion of the runoff.

The Caltrans Permit requires that the stormwater runoff water volumes used for sizing BMPs be based on the 85th percentile, 24-hour storm event (Water Quality event). WQV can be calculated by determining the Water Quality event depth, multiplying by the area, and the volumetric runoff coefficient. The depth is typically determined by using Basin Sizer (a Caltrans design tool), but other methods may be used to calculate the WQV. Basin Sizer can be downloaded from the following website:

<http://www.dot.ca.gov/hq/env/stormwater/watertool/basinsizer.htm>

Basin Sizer: This design tool allows the PE to select rainfall stations near the project site through a graphical interface of a map of California that shows rainfall stations, state and federal highways, and rivers. Once the PE has located the project site on the map, the PE chooses the rainfall station(s) closest to or most representative of the site to be used in the WQV/WQF calculations. When volume-based BMPs are being evaluated for the project, the PE uses the Caltrans tab. The Caltrans tab automatically calculates the 85th percentile 24-hour storm event based on the chosen rainfall station or can be an interpolation of multiple station data. This calculation is the storm event rainfall depth in inches. Once the precipitation depth is obtained from Basin Sizer, the PE then completes the WQV calculations. When flow-based BMPs are being evaluated for the project, the PE should use the rainfall intensities listed in Section 5.3.3.3. The rainfall intensity is then used with the Rational Method to calculate WQF.

The Historic and California Stormwater Quality Association (CASQA) tabs include options for WQV sizing using the Maximized Volume Method, California Stormwater BMP Handbook Approach, and Urban Runoff Quality Management Approach. The WQV calculated using Basin Sizer Historic method will usually be an overestimate because of the composite runoff coefficient C which is intended to

calculate peak discharges using the Rational Method. Therefore, the PE should use the precipitation depth from the Caltrans tab in Basin Sizer along with the volumetric runoff coefficient R_v in the Small Storm Hydrology Method described in the next section to calculate the project WQV.

5.3.3.1 Volumetric Runoff Coefficient for Calculating Water Quality Volume

For volumetric BMP sizing, the following equation from the Small Storm Hydrology Method (SSHM) should be used, as it takes into account the smaller depth of the Water Quality event. This will replace the use of rational method C (runoff coefficient) values for the calculation of WQV.

$$V_R = R_v(P/12)A$$

Where:

V_R = Runoff volume (ft³)

R_v = Volumetric Runoff Coefficient (unitless)

P = Precipitation Depth (in) – from Basin Sizer

A = Contributing Drainage Area (ft²)

The SSHM is recommended for stormwater design to calculate the volumetric sizing of stormwater BMPs because it was developed specifically for this purpose and it has been adopted by many municipalities and CASQA. For Caltrans implementation, a table of R_v values which represent a mix of both impervious and pervious areas is provided (see Table 5-2) and scenarios that are appropriate for highway use are identified. The highway design scenarios we expect designers to encounter and ways to calculate the water quality volume ($WQV = V_R$) are presented below:

1. For areas with over 50% impervious surfaces and that drain the impervious area to pervious area, use Table 5-2 based on the percent impervious of the CDA or use the Urbonas equation which is a single calculation for the entire CDA using a composite R_v .

$$V_R = R_v(P/12)A, \text{ where } V_R \text{ is the WQV of the entire CDA.}$$

For the next geometric drainage scenarios, a composite V_R (WQV) calculation is required, where $WQV = V_{R1}(\text{WQV impervious}) + V_{R2}(\text{WQV pervious})$ is calculated for the total WQV for the site.

$$V_{R1} = R_{v1}(P/12)A_1 \quad V_{R2} = R_{v2}(P/12)A_2 \quad V_{R1} + V_{R2} = V_{R \text{ total}}$$

The R_v values for scenarios 2-4 should be taken from Table 5-2 for both impervious and pervious areas. For pervious areas determine the soil type and take a weighted average of the R_v appropriate for the site condition.

2. For projects that are designed with hydraulically separated pervious and impervious areas, determine separate R_v values, calculate separate WQVs for impervious and pervious drainage areas, and then combine for total WQV.
3. For projects where the impervious surfaces are less than 50% of the drainage area of the site, determine separate R_v values, calculate separate WQVs for pervious and impervious areas, and then combine for total WQV.

4. For projects where pervious areas drain to impervious areas, determine separate R_v values, calculate separate WQVs for pervious and impervious areas, and then combine for total WQV.

Description	Volumetric Runoff Coefficient (R_v)
100% Impervious	0.89
90% Impervious	0.73
80% Impervious	0.60
70% Impervious	0.49
60% Impervious	0.41
50% Impervious	0.34
Clayey Soils ¹	0.22
Sandy Soils ¹	0.03

¹Value for an average California 85th percentile, 24-hour storm event depth of 1.26 inches

The SSHM volumetric runoff coefficients shown in the table above are from *Caltrans Technical White Paper: Runoff Coefficient Evaluation for Volumetric BMP Sizing*, dated May 29, 2015. The white paper can be found at: <http://www.dot.ca.gov/hq/oppd/stormwtr/guidance.htm>

As more data is received on this, the volumetric runoff coefficient table may be updated to reflect more accurate values for runoff from the highway environment.

5.3.3.2 Water Quality Volume and Water Quality Flow Combined Mechanism for Treatment

For locations where the entire water quality volume cannot be infiltrated, flow-through treatment devices must be considered for treatment of the remaining WQV. The Caltrans Infiltration Tool is a method for calculating the WQV treated; other methods may be used.

5.3.3.3 Water Quality Flows (WQF)

The Rational Method can be used for calculations of WQF. The calculations for runoff coefficients in HDM 819.2 are applicable for larger storms used for highway drainage design and flood flows and therefore may overestimate the WQF. The PE should use the flow-based runoff coefficients listed in Table 5-3 with the Rational Method to calculate WQF.

Table 5 3. Flow Based Runoff Coefficients	
Surface Type	Runoff Coefficient (C)
Roofs	0.90
Concrete	0.80
Stone, brick, or concrete pavers with mortared joints and bedding	0.80
Stone, brick, or concrete pavers with sand joints and bedding	0.10 - 0.70
Asphalt	0.70
Pervious concrete	0.10 - 0.60
Porous asphalt	0.10 - 0.55
Grid pavements with grass or aggregate	0.10
Crushed aggregate	0.10
Grass	0.10

The flow-based runoff coefficients shown in the table above are from *Runoff Coefficients for Estimating Water Quality Flow Rates (CTSW-TM-16-314.17.2D)*, February 8, 2017.

The rainfall intensities listed below are from the *Statewide Stormwater Management Plan (SWMP)* and have been previously negotiated with the California State Water Resources Control Boards (SWRCBs) and Regional Water Quality Control Boards (RWQCBs). These rainfall intensities should be used as the basis for designing the approved flow-based Treatment BMPs.

The listed values of rainfall intensity are used in the Rational Formula ($Q=CiA$) to estimate runoff from contributing drainage areas that would discharge flow to flow-based Treatment BMPs. The resulting runoff rate would be the design WQF to be used at a specific site.

- Region 1 (North Coast) – 0.22 inches/hour ("/hr) for Siskiyou and Modoc Counties, 0.27 "/hr for Trinity, Mendocino, Glen, and Lake Counties and 0.36 "/hr for Del Norte, Humboldt, Marin, and Sonoma Counties.
- Region 2 (San Francisco) – 0.20 "/hr region wide.
- Region 3 (Central Coast) – 0.22 "/hr for Santa Cruz County and for that portion of San Mateo County within the region; 0.20 "/hr for Santa Clara County, 0.18 "/hr for San Benito, Monterey and San Luis Obispo Counties and 0.26 "/hr for Santa Barbara County and that portion of Ventura County within the Region.
- Region 4 (Los Angeles) – 0.20 "/hr region wide.
- Region 5 (Central Valley) – 0.16 "/hr for portions of Lassen and Modoc Counties within the Region, all areas of Region below 1,000' elevation north of and including Sacramento and Amador Counties and below 2,000' elevation south of Sacramento and Amador Counties, and all elevations on the west side of the Region (rain shadow side of the Coast Range), 0.20 "/hr for elevations in the Sierra Nevadas between 1,000' and 4,000' in the north and between 2,000' and 4,000' in the south, and 0.24 "/hr for all elevations above 4,000' in the Sierra Nevadas.

- Region 6 (Lahontan) –
 - Where there are location-specific requirements (Truckee River, East and West Forks Carson River, Mammoth Creek, and Lake Tahoe), the WQF will conform to the Basin Plan requirement for runoff from impervious areas. Where runoff from pervious areas contributes to the flow to the treatment device, the WQF value to be used will be as specified in the following two items:
 - The WQF to be used for that portion of the Lahontan Region including Inyo County and areas southward will be 0.16 "/hr. The WQF to be used for pervious surface areas within the Mammoth Creek watershed will be 0.16 "/hr.
 - For all other areas of the Lahontan Region other than as indicated in item a) above, the WQF to be used will be 0.20 "/hr. This includes pervious surface areas of the Truckee River, Carson River East and West Forks and Lake Tahoe Hydrologic units.
- Region 7 (Colorado River) –0.16 "/hr region wide.
- Region 8 (Santa Ana River) –0.20 "/hr region wide.
- Region 9 (San Diego) –0.20 "/hr region wide.

In addition to designing for the WQF, the PE must also insure that the flow-based Treatment BMPs include a bypass or an overflow device to convey peak discharges from larger design storms consistent with Section 861.3 of the *HDM*.

5.3.4 Selection Prioritization of Treatment BMPs

The PE shall follow the Checklist T-1, Part 1 process when Treatment BMPs are required for the project. The PE then sites Treatment BMPs throughout the project that are designed to treat a cumulative impervious area that is equal to or greater than the PCTA. To assist the PE, Checklist T-1, Part 1 includes an overall project treatment tracking table, Table E-1. Table E-2 tracks the areas treated and percent WQV/WQF treated for each BMP.

When selecting the preferred BMPs, the PE should also consider information identified by the environmental document, which may affect the selection of Treatment BMPs for the design. Water quality requirements for TMDLs, 303 (d) listings, ASBS, highway operations (traction sand), drainage, safety, and other feasibility parameters should all be considerations in the final design of Treatment BMPs.

Appendix B provides general descriptions and information for the approved Treatment BMPs, as well as criteria for considering existing roadway features as Treatment BMPs. Design guidelines for each BMP can be found on the Department's website at:

http://www.dot.ca.gov/hq/oppd/storm1/caltrans_20090729.html

5.3.5 Incorporation of Non-Approved Treatment BMPs

Only Treatment BMPs that have been approved for statewide use should be incorporated into projects. If project conditions prohibit the use of approved BMPs, then the PE must consult with the District/Regional Design Stormwater Coordinator. The district has the option of proposing the incorporation of a non-approved BMP as a pilot project see BMP Development and Implementation in Section 4 of the SWMP. The Stormwater Advisory Teams (SWATs) and the appropriate HQ functional units must approve this proposal. The district's proposal to HQ for a pilot project should include the following information:

- Description of project (including why approved BMPs cannot be implemented);
- Description of proposed pilot BMP (including anticipated costs and benefits);
- Anticipated life-cycle maintenance requirements;
- Monitoring Program; and
- Evaluation criteria.

If the SWATs and the HQ functional units approve the pilot project, the district would be allowed to incorporate the non-approved BMP into their project. It should be noted that a pilot technology is normally approved only for deployment in a limited quantity within a given project. Pilot technologies are not typically deployed in large numbers within a single project, or deployed within multiple projects unless it would be considered necessary to evaluate the performance under varying site conditions. The purpose of the pilot project is to evaluate the feasibility of a particular technology, with further deployment being dependent upon the outcome of the pilot project.

The pilot BMP design and the BMP contributing drainage areas must be documented in the Stormwater Data Report. The contributing drainage area documentation must include an accounting of impervious areas that generate post construction treatment, Alternative Compliance, or CUs, and all pervious areas that generate CUs.

5.4 Documenting Treatment

The PE is responsible for quantifying and reporting the areas treated by the project BMPs. Document all treated areas in the project SWDR using Tables E-1 and E-2 or equivalent tables (see Section 6.6 for additional information). There is considerable information to be documented for each permanent BMP during the project development process. Information will be documented for individual BMPs, overall project compliance, and if applicable, Alternative Compliance use or generation.

Any project that reduces the effectiveness of an existing treatment control must provide equivalent treatment as described in Section 4.4.1. All projects that require post construction treatment must provide treatment for the entire PCTA (defined in Section 4.4):

$$PCTA = NNI + RIS + ATA \text{ (Condition 1 Impervious and Condition 2)}$$



The total area to be treated by project BMPs can be summarized by the following equation (defined in Section 4.4):

$$\text{Total Area to be Treated} = \text{NNI} + \text{RIS} + \text{ATA (Conditions 1 and 2)} + \text{TMDL CU}$$

If it is not feasible for the project to provide treatment for the entire PCTA and ATA 1, the PE must inform the District/Regional NPDES Coordinator to identify an alternative compliance strategy.

Treatment provided for TMDL compliance units is encouraged above PCTA requirements and can also be tracked as Alternative Compliance. Treatment provided for PCTA, TMDL CU, and alternative compliance, must be documented in the SWDR.

When a project is located in a TMDL watershed, Caltrans is required to meet the post construction stormwater treatment requirements before CUs are generated. CUs can be generated under the following scenarios: post construction treatment beyond the NIS once PCTA (ac) treatment has been met; post construction treatment of pervious areas (ac) other than ATA 1 (Pervious); pervious areas that have been stabilized (ac); and other elements aiding TMDL compliance, such as fish passage. CU may also be generated by cooperative implementation projects or where a reduction in pollutant loads can be documented and approved by the SWRCB.

The PE is responsible for completing the treatment summary tables (Table E-1 Overall Project Treatment Summary Table and Table E-2 Individual Treatment BMP Summary Table). Districts may modify these tables based on their needs. If the District uses a modified Table E-2, the WQV or WQF (%) Treated for each Treatment BMP must be reported since this data is not captured in the SWDR Summary Spreadsheets.

THIS PAGE INTENTIONALLY LEFT BLANK.

6 Stormwater Data Report Development Process

6.1 Introduction

The Stormwater Data Report (SWDR) is a document that summarizes the stormwater quality issues and design decisions made regarding project compliance with the Department's National Pollutant Discharge Elimination System (NPDES) Permit, commonly referred to as the Caltrans Permit. A SWDR is prepared for every project except for emergency projects done under Force Account. The purpose of this section is to provide a consistent approach in the preparation of the SWDR for different types of projects and to describe the reports evolution through the project development process. The SWDR and associated checklists are initiated in the Project Initiation Document (PID) phase, refined during the Project Approval/Environmental Document (PA/ED) phase, and finalized during the Plans, Specifications, & Estimates (PS&E) phase. The SWDR and its corresponding template and checklists are described in this section and are included in the appendices.

6.2 Project Types, Scopes, and Magnitude

The Department manages many types of projects with different scopes and magnitudes. For compliance with the Caltrans Permit, projects can be segregated into three major categories: routine maintenance projects, new development/redevelopment projects, and design-build projects.

6.3 How the SWDR Fits into the Project Delivery Process

6.3.1 Project Initiation Document (PID)

The purpose of PID is to establish a well-defined purpose and need statement and a proposed project scope with a reliable cost estimate and schedule. The PID is used for programming the project, for proceeding to the environmental evaluation, and for the presentation of project alternatives.

The PID process is intended to obtain management approval of candidate projects, identify right-of-way (RW) acquisition needs, and determine costs for programming the project. Therefore, it is essential that all work incidental to the project, including stormwater quality items, be included in the PID scope and cost estimates. It is understood, however, that a project's scope may change as environmental or other studies are completed.

A Preliminary Environmental Assessment Report (PEAR) is prepared by the Environmental Unit when requested by the Design Unit and is used to provide necessary information for the completion of a PID. The purpose of a PEAR is to determine whether there are any potentially significant environmental issues, including water quality, which could affect the viability of any project alternative.

The SWDR level of detail at this phase may be limited based on the available information developed for the project, and the SWDR should reflect the information presented in the PEAR and PID. The Project Engineer (PE) should prepare the SWDR in coordination with the designated Environmental Staff who prepared the PEAR to verify that the information included in both documents is consistent.

6.3.2 Project Approval/Environmental Document (PA/ED)

The PA/ED process is generally initiated after the PID is approved and the project is programmed. Under certain conditions, the PID and PA/ED phases are completed concurrently; when this occurs, the PE should coordinate the SWDR efforts with the District/Regional Design Stormwater Coordinator. At the PA/ED phase, it is intended to obtain management approval of a selected project alternative, identify RW acquisition needs, further define costs, and develop the necessary environmental documents in accordance with the *California Environmental Quality Act* and *National Environmental Policy Act* (CEQA/NEPA).

In general, the Environmental Unit in consultation with the Project Development Team (PDT) will conclude if there is potential for one or more substantive water quality impacts to the project. If so, a Water Quality Assessment Report (WQAR) is prepared, typically during the PA/ED phase of a project. The WQAR is a technical report included in the appendix of the CEQA/NEPA document and is typically prepared by the Environmental Unit. The PE should coordinate with the Environmental Unit staff and with the District/Regional Design Stormwater Coordinator to ensure updates to the SWDR are consistent with the project WQAR and/or approved Environmental Document. PID and PA/ED SWDRs are planning documents and shall not be referenced in the Environmental Document or the WQAR.

The PA/ED SWDR supports the Project Report and should not be signed until the Environmental Document is approved as the SWDR needs to reflect the preferred alternative.

6.3.3 Plans, Specifications, and Estimate (PS&E)

The purpose of the PS&E process is to prepare full, complete, and accurate plans, specifications, quantities, and estimates of cost for the selected project alternative including Best Management Practices (BMPs) and other water quality measures. These documents are used for eventual contract advertising and bidding on a project. The SWDR documents the stormwater quality strategy of the project and will be updated during this phase to document the design details of BMPs incorporated into the project.

6.4 Stormwater Data Report (SWDR)

The SWDR documents the relevant stormwater design decisions made regarding BMP considerations and potential water quality impacts.

Two goals of the SWDR are:

- To provide sufficient information at all phases to document the project's site data (see 6.4.3.2) and the overall stormwater quality strategies to meet the Department's regulatory commitments; and
- To obtain and document consensus between the different functional units and to document coordination efforts with the Regional Water Quality Control Board (RWQCB) regarding water quality issues.

There are two types of SWDRs, a Short Form and a Long Form. See Appendix E to understand the use of these forms. The following provides general information on each section of the SWDR that should be discussed. Checklists that support each section of the SWDRs are provided in the appendices to assist the PE in developing the SWDR.

6.4.1 Cover Page

The SWDR cover page is intended to provide a brief summary of the stormwater quality issues and stormwater requirements applicable to the project. The Short Form SWDR cover page lists questions that must be answered to determine if a project qualifies for preparation of a Short Form SWDR. The Short Form SWDR must be signed by the PE (Licensed Engineer or Landscape Architect) in charge of the SWDR development and the District/Regional Design Stormwater Coordinator.

The Long Form SWDR must be signed by the PE (Licensed Engineer or Landscape Architect) in responsible charge of the project, the Project Manager (PM), the Maintenance Representative, and the District/Regional Design Stormwater Coordinator who verifies that stormwater quality design issues have been identified and accurately documented in the SWDR.

The PE's stamp is only required at PS&E. The PS&E milestone is not complete until the SWDR is stamped by the PE, and signatures from the applicable functional unit representatives have been obtained. The District/Regional Design Stormwater Coordinator should be the last to sign the cover page.

6.4.2 Section 1 - Project Description

Section 1 of the SWDR, *Project Description*, is required for all project types and at all phases.

The project description should describe the type of project and the major engineering features and improvements proposed. The project description can be taken from other project reports. At the PID phase, the project description will describe all alternatives of the improvements considered. At the PA/ED phase, the project description will only include the preferred alternative. At the PS&E phase, the project description will summarize the major project engineering features.

A description of how the disturbed soil area (DSA) was calculated must be provided in Section 1. At the PID and PA/ED phases, the DSA should consider all areas where ground disturbance is anticipated. During the PS&E phase, the DSA should include all areas of grading work (cut/fill), new impervious surface (NIS), and any unstabilized areas designated for construction staging and access to the project. Routine maintenance activities are exempt from the DSA calculation requirement in the *Construction General Permit (CGP)*.

Describe whether or not Treatment BMPs are required by documenting the NIS, which includes the net new impervious (NNI) and the replaced impervious surface (RIS).

If the NIS is 1 acre or more, a description of how the PCTA was calculated must be provided. This will document the basis of the PCTA listed on the SWDR Cover Sheet. If NIS is calculated as less than one acre, document PCTA as "not applicable" on the SWDR Cover Sheet. Document the PCTA by determining the NIS and the Additional Treated Area (ATA) for the project, see Section 4.4. Describe any existing Treatment BMPs that are being removed or modified as part of the project and describe how the previously treated area is being addressed.

Note: Projects with a pre July 1, 2013 PID approval date, the Replaced Impervious Surface (RIS) is not required to be treated or used to trigger treatment. Projects that completed the PID phase prior to July 1, 2013, may use the following sample text:

The PID for this project was signed on MM/DD/YYYY, and therefore the project is grandfathered under the Caltrans Permit (Section E.2.d). This project is subject to the treatment threshold requirements contained within the 1999 Caltrans Permit.

6.4.3 Section 2 – Site Data and Stormwater Design Issues

6.4.3.1 Checklists SW-1, SW-2, and SW-3

Section 2 of the SWDR summarizes the applicable information provided from Checklist SW-1, SW-2, and SW-3 in Appendix E. As the project progresses the checklists are updated and finalized. Checklists SW-1, SW-2, and SW-3 are provided for the purpose of assisting the PE in developing the SWDR and are not required to be attached to the SWDR, unless requested by the District/Regional Design Stormwater Coordinator.

Using the categories in Checklist SW-1, list the references used to gather pertinent information required for stormwater planning and design. Checklist SW-1 should be completed at all phases, citing the source and date of the information collected for each entry and document pertinent information in the SWDR narrative.

Checklist SW-2 provides a guide to collecting information relevant to project stormwater quality issues. The PE should coordinate with other Caltrans functional units (Environmental, Landscape Architecture, Maintenance, etc.) and the District/Regional Design Stormwater Coordinator as necessary when compiling and reviewing the information required by SW-2. This information is critical in facilitating the selection and design of the preferred BMPs.

Checklist SW-3 provides direction to the PE to avoid or reduce potential stormwater impacts. The planning phase represents the greatest opportunity to avoid adverse water quality impacts as alignments and RW requirements are developed and refined. Avoiding impacts may reduce or eliminate the need for mitigation measures. The PE should coordinate with the Environmental Unit when compiling and reviewing the information required by Checklist SW-3.

6.4.3.2 Discussion of Pertinent Data

The five main categories for site data collections are water quality, geotechnical, topographic, hydraulic, and climatic. This data should be collected from the various functional units. Field visits should also be conducted to gather pertinent data.

Project-specific information may vary depending on the project phase. General information from credible online sources, including Department websites (e.g., Water Quality Planning Tool) or other government websites may be used during the PID phase. As the project progresses the SWDR must be updated to reflect the new and updated project information. Generally, a Hydrology and Hydraulic Report/Drainage Report, a Geotechnical Design Report, and a Materials Report are prepared and the pertinent stormwater related data from these reports should be summarized in the SWDR.



Water Quality Data

The PE should coordinate with the Environmental Unit and the District/Regional NPDES Coordinator to determine the water quality data to be presented. This coordination enables the PE to share project-specific information, and to ensure consistency between the evaluation of the project design or alternatives and the completion of the stormwater checklists.

- Identification of receiving water bodies:
 - Describe crossings and distance from the project's outfalls
 - Include the hydrologic area or sub-area (name and/or number)
 - Identify if any of the receiving water bodies are on the 303(d) list / describe pollutants of concern (POC)
 - Identify if the project is in a Total Maximum Daily Load (TMDL) watershed where Caltrans is a named stakeholder
 - Identify if the project is directly discharging to an ASBS and the distance to the Areas of Special Biological Significance (ASBS)
- Existing hazardous material/waste information:
 - Describe hazardous waste or contaminants that may impact stormwater BMP selection (e.g., soils containing aerially deposited, groundwater contamination)
 - If the construction site area is known to be contaminated from past land uses, then the PE should give special consideration to including the additional analyses within the project. The District Hazardous Waste Coordinator and District NPDES Coordinator should be consulted to determine the necessary monitoring, so that it may be accounted for in the PS&E.
- Relevant Pollution Control Requirements
 - Identify which RWQCB(s) jurisdiction the Project is within and any pertinent regional criteria that may be applicable to Project (discuss project specific permit requirements in Section 5 of the SWDR, see Section 6.4.6)
 - Describe specific water quality objectives or requirements from the Basin Plan that apply to the Project
 - Summarize existing Treatment BMP(s) within the project limits and describe how the BMP(s) or contributing watershed(s) will be impacted by the project
 - Summarize any additional water quality requirements applicable to the Project or that have been identified by the District/Regional NPDES Coordinator

If separate reports have been prepared for any of the above and the topic is pertinent to the project's stormwater quality strategy, summarize the data in the SWDR narrative.

Geotechnical Data

Geotechnical data should be included in the SWDR when there are mass stability issues or whenever there are geotechnical issues that should be considered in the development and implementation of Treatment BMPs. For projects where permanent stormwater treatment devices are proposed, infiltration testing and depth to seasonal high groundwater may be needed.

At the PID phase, if historic soil information or previous geotechnical reports from projects within the area are not available, the Natural Resources Conservation Service Soil Survey Reports and Maps

can be used to identify general soil features including hydrologic soil groups and erosion potential. If earthen type BMPs are anticipated, coordination of geotechnical tests required for inputs to the Caltrans Infiltration Tool are recommended to be requested at the PID phase only if adequate funding and Treatment BMP locations are available. Refer to Appendix B and the OHSD design guidance website for information that is needed during BMP design.

At the PA/ED phase, preliminary geotechnical or site investigation studies are typically prepared for projects. These studies should be used to further develop the discussion of the geotechnical features within the project. Well records can provide information regarding the depth from surface to seasonal high groundwater.

At the PS&E phase, the project-specific Geotechnical Design Report is typically finalized and should be used to update geotechnical information presented in the SWDR. The SWDR should generally describe features that relate to stormwater quality design (e.g., types of soils, groundwater depth and conditions, dewatering operations that may be necessary). When stormwater treatment is required, this information may include infiltration rates and any detailed soil testing performed at proposed stormwater Treatment BMP locations.

Topographic Data

Survey needs should be evaluated and identified early in the PID process and throughout the entire project development process. After the first evaluation of survey needs, the PE should submit the initial survey request accompanied by a location map. At the PID and PA/ED phases, or for projects where detailed contour mapping is not available, general topographic data can be obtained from United States Geological Survey (USGS) Quad Maps and aerial mapping or photo mosaics.

During the PS&E phase, or as topographic and survey information becomes available, the SWDR should briefly describe:

- Survey of existing features that may be used for stormwater design
- Existing cover and types of vegetation present

Hydraulic Data

The SWDR should describe the general drainage pattern within a project area, and discuss drainage improvements that may be incorporated into the project that have the potential to effect water quality. The USGS StreamStats can also be used during PID phase for determining rapid stability assessment (RSA) applicability. The SWDR should present the following hydraulic data as it becomes available, depending on the complexity and phase of the project:

- Rapid Stability Assessment (RSA): When an RSA is required, summarize the water bodies evaluated and if higher level analyses are necessary. Document the number of RSAs, and number of Levels 1-3 performed. Discuss additional work proposed for the project due to the Levels 1-3 performed
- Groundwater Data
- Stream Flow Data
- Drainage Area – Routes and patterns (define sub-basins)

- Identification of drainage areas affecting or tributary to drinking water reservoirs and/or recharge facilities as identified in the District Work Plan.

The local Maintenance Supervisor should be consulted to identify existing drainage and erosion problems.

Climatic Data

At all phases, general climatic data should be summarized. If vegetated stormwater measures are considered, it must be determined in consultation with District Landscape Architect (DLA) whether the area's climate is favorable for long-term vegetation establishment. Precipitation information should be presented, as necessary, for sizing potential BMPs.

The following rainfall information should be presented as applicable:

Caltrans Permit Post-Construction Requirements:

- 85th percentile 24-hour storm event used for the design of water quality volume type Treatment BMPs
- Rainfall intensity used for the design of water quality flow type Treatment BMPs

CGP Requirements (at PS&E, as applicable):

- Rainfall totals from a 10-year, 6-hour and 24-hour event expressed in inches of rainfall for determining detention time for sediment basins and active treatment systems
- Rainfall total for the 5-year, 24-hour storm for defining the exemption to receiving water monitoring for risk level 3 projects

6.4.4 Section 3 –Construction Site BMPs

Section 3 of the SWDR, Construction Site BMPs, is required for all project types and at all phases. All projects are required to consider and implement Construction Site BMPs to prevent discharge of sediment or contaminants from the construction site and impacting receiving waters. If the project site is subject to stormwater run-on flows from off-site sources, the PE must identify and quantify the expected flow rates so appropriate control measures (i.e., pipe or channel) can be implemented to convey concentrated flows around or through the site. The Construction Site BMP Consideration Form is a resource to assist in developing a Construction Site BMP strategy. Refer to 6.4.4.1 for documenting Construction concurrence.

At the PID phase, a general discussion of the expected Construction Site BMP strategy should be provided. The strategy should consider the potential impacts to water quality during construction, in accordance with Water Pollution Control Program (WPCP) or Stormwater Pollution Prevention Plan (SWPPP) requirements of the CGP. At this phase, the need for a bioassessment monitoring should be evaluated and updated throughout subsequent project phases as the scope is refined. Appendix C provides a description of approved Construction Site BMPs, and Appendix F provides general guidance on estimating Construction Site BMP costs.

At the PA/ED phase, the Construction Site BMP strategy should be updated based on the selected alternative and planned geometry. Additionally, the strategy should be expanded based on findings from the related studies (environmental, geotechnical, etc.) prepared for the project.

At the PS&E phase, the Construction Site BMPs should be selected and documented. Checklists CS-1, Parts 1-6 are provided in Appendix C to assist the PE in selecting appropriate individual and lump sum Construction Site BMPs. Unless requested by the District/Regional Design Stormwater Coordinator, these checklists are not required to be attached to the SWDR. The selection of Construction Site BMPs should be coordinated with the Construction Stormwater Coordinator and Construction field personnel. To further identify Construction Site BMPs that are appropriate for a project, refer to the following:

- *Storm Water Quality Handbook – Construction Site Best Management Practices Manual* (<http://www.dot.ca.gov/hq/construc/stormwater/>)
- Division of Construction – Stormwater Quality webpage (<http://www.dot.ca.gov/hq/construc/stormwater/>) contains links to resources for developing a SWPPP, a WPCP, and stormwater quality information that can be included in the Information Handout.
- *California Stormwater Quality Association (CASQA)– Stormwater Best Management Practice Handbook Portal: Construction*

The SWDR should provide estimate information:

- Provide an estimate (costs are for Caltrans internal use only) for Construction Site BMPs (see F.3 Estimating Methods) (required at all phases). Caltrans Construction BMP Cost Estimator may be used to prepare the Construction BMP Estimate, and can be downloaded from the following website:

<http://www.dot.ca.gov/hq/oppd/stormwtr/cost-estimating.htm>

If at planning phases, the following language could be used:

Project specific BMP measures will be specified and quantified during the design phase. Temporary construction BMPs have been estimated at (___%) of the total project cost (\$____) in accordance with the Project Initiation Cost Estimate Method, Appendix F.3.1, 2017 PPDG.

If at design phase, the Construction BMP Estimate is a required attachment and can be referenced in Section 3 of the SWDR.

- Identify existing features, structures, facilities, or practices that may be used by the Contractor during construction for stormwater quality purposes.
- Identify and quantify the expected stormwater run-on to the project site from off-site sources.
- Identify whether dewatering will be required during the construction of the project. Describe construction operations requiring dewatering.
- Describe non-standard BMPs necessary to protect water quality or as required by project-specific permits (e.g., an Active Treatment System (ATS), clear water diversion).

The BMPs identified in the SWDR should reflect the measures included in the plans and special provisions anticipated during the PS&E phase. The SWDR should describe the decisions or rationale behind the selection of BMPs, non-standard BMPs and specifications, or other specialty items related to stormwater compliance developed by the PE.

6.4.4.1 Construction Concurrence Documentation

Before requesting concurrence on the Construction Site BMP strategy, the PE should develop the SWDR and supporting documentation justifying BMP selection, quantities, locations, and monitoring requirements. Documentation may include maps showing upstream watersheds including calculations, design details, and BMP controls for site run-on, as applicable. This may be useful for determining Construction Site BMPs including those required to divert water around or through the project site. Consider using the Construction Site BMP Consideration Form when developing the BMP strategy.

6.4.4.2 CGP Coverage and Risk Level Determination

Generally, projects that disturb one acre or more of soil must apply for coverage under the CGP and will require a project risk level (RL) determination. The project RL determination should be summarized in Section 3 of the SWDR. Projects that disturb between 1 and less than 5 acres of soil may be exempt from the CGP through a Rainfall Erosivity Waiver. For projects that qualify for a Rainfall Erosivity Waiver, the PE must ensure the construction dates used to obtain the waiver are reflected in the project specifications and that the information is provided to the RE to enter into Stormwater Multiple Application Report Tracking system (SMARTS).

The R factor is calculated using the *EPA Rainfall Erosivity Calculator* at:

<http://water.epa.gov/polwaste/npdes/stormwater/Welcome-to-the-Rainfall-Erosivity-Factor-Calculator.cfm>

Although use of the EPA Rainfall Calculator to determine for Erosivity Waiver and the R Factor is required by the CGP, it is not always available. At such times, the California State Water Resources Control Board (SWRCB) suggests the use of RUSLE2 or the use of the manual tabular method as described in *EPA 833-F-00-014 Environmental Protection Agency Fact Sheet 3.1*.

Projects that do not discharge to a receiving water body do not need CGP coverage.

Bioassessment monitoring is required for all RL 3 projects that have 30 acres or more of disturbed area and directly discharge runoff to a freshwater wadeable stream or tributary stream that is either listed by the State Water Board of United States Environmental Protection Agency (USEPA) as sediment impaired and/or has the beneficial uses of SPWN, COLD, and MIGRATORY. See Appendix F for more information.

The Rainfall Erosivity Waiver and RL determination should be performed and refined at each subsequent phase of a project as the project schedule is developed and detailed information regarding the existing site characteristics become available.

Risk Level Determination

The CGP contains a risk-based permitting approach by establishing three levels of risk possible for a construction site. RL is calculated in two parts: 1) project sediment risk, and 2) receiving water risk. The PE is to determine the RL for a project when a SWPPP under the CGP is to be prepared during construction. The RL determination quantifies sediment and receiving water characteristics and uses these results to determine the overall site RL, defined as either Levels 1, 2, and 3. Level 3 is the highest RL and requires extensive monitoring and reporting. Projects with non-contiguous

construction areas (more than ¼ mile apart) may be required to perform RL determinations at each area. A complete methodology for determining the RL for a project is available at:

<http://www.dot.ca.gov/hq/oppd/stormwtr/risk-guidance.htm>

In addition to summarizing the RL determination in Section 3, the RL determination documentation is required as part of the Required Attachments of the SWDR.

6.4.4.3 Stormwater Pollution Prevention Plan (SWPPP) and Water Pollution Control Program (WPCP)

The Caltrans Permit requires a SWPPP for every project that meets the definition of Construction as outlined in the CGP. Specifically, a SWPPP is required when one of the following conditions exists:

- The project involves one (1) acre or more of contiguous (less than ¼ mile apart) soil disturbance; or
- The RWQCB designates in writing that the project requires a SWPPP based upon water quality concerns, even if the project does not meet the preceding requirement.

The following exceptions may apply:

- Projects that solely maintain the original line and grade, hydraulic capacity, and original purpose of the facility are defined as routine maintenance and excluded from coverage under the CGP;
- Projects that do not directly or indirectly discharge to a receiving water body;
- Projects that have land disturbance between 1 and less than 5 acres and an R factor less than 5 may qualify for a Rainfall Erosivity Waiver (See Sections 1.4.4.1 and 6.4.4.2);
- All projects within the Lake Tahoe Hydrologic Unit must adhere to the general construction permit issued by the Lahontan RWQCB;
- Projects within tribal lands or federal reserves must adhere to the USEPA CGP;
- Projects, or portions thereof, that discharge to ASBS must be granted an approved exception by the SWRCB; and
- Projects, or portions thereof, that discharge to a combined sewer system or in combination with municipal sewage.

Consult with the District/Regional Design Stormwater Coordinator to determine if any of these exceptions apply. All applicable exceptions should be documented in the SWDR.

Projects that do not require a SWPPP must have a WPCP. The purpose of both the SWPPP and the WPCP is to identify construction/contractor activities that could discharge pollutants in stormwater, and provide descriptions of measures or practices to control these pollutants. Both the SWPPP and the WPCP are the responsibility of the Contractor to prepare.

6.4.4.4 Active Treatment Systems (ATS)

An ATS may sometimes be necessary to meet the effluent limits of the CGP for turbidity and pH in stormwater. Under the CGP, an ATS is recommended for use at high risk work sites, including those



with limited space for sizing proper containment and detention facilities. Information on the use, selection, and cost estimating for ATS is provided in Appendices C and F.

If use of an ATS has been included in the design, summarize the evaluation of why additional Construction Site BMPs could not be used to comply with the CGP requirement in the SWDR narrative. Also, document the ATS design assumptions and include all design calculations as part of the Supplemental Attachments.

6.4.5 Section 4 – Maintenance BMPs

Section 4 of the SWDR, Maintenance BMPs, is required when Maintenance BMPs, independent of other treatment, are deployed on a project. These BMPs can be found in *Caltrans Stormwater Quality Handbook Maintenance Staff Guide* at the following website:

http://onramp.dot.ca.gov/hq/maint/manuals_ref/manuals.htm. If Maintenance BMPs are not deployed, then state “No Maintenance BMPs independent of other Treatment BMPs apply to this project”. The PE should coordinate with the Designated Maintenance Representative or Maintenance Area Manager to determine Maintenance BMP needs on a project.

A typical Maintenance BMP related to stormwater quality that could be considered are anti-litter signs based on public need. Caltrans conducts a signage program that warns against dumping and littering. Another example is storm drain stenciling. Stenciling messages at storm drain inlets located at highway facilities such as park and ride lots, rest areas and vista points assists the Department in educating the public about stormwater runoff pollution. PEs should contact the District Maintenance Stormwater Coordinator who can identify if the project should provide Maintenance BMPs such as Treatment BMP location signage (i.e., paddle marker), anti-litter signs, and storm drain stenciling including types, and specifications.

Maintenance BMPs ancillary to Treatment BMPs should be described as part of the strategy in the Treatment BMP section.

6.4.6 Section 5 - Other Water Quality Requirements and Agreements

Section 5 of the SWDR, Other Water Quality Requirements and Agreements, is only required if project-specific permits, licenses, agreements, certifications (PLACs), or other communication related to stormwater or water quality apply to the project. If no project-specific PLACs or other communication or coordination with the RWQCB apply to the project, then state “No project-specific PLACs, or other communication or coordination with the RWQCB apply to the project.”

The PE should consult with the District/Regional NPDES Coordinator regarding the complexity of the project and the need to consult with the RWQCB or other permitting agencies at the PID phase of the project. Consultation with the RWQCB and local regulatory agencies at this early phase is strongly recommended to coordinate project issues and develop consensus for controversial or complex stormwater quality issues. The number of coordination meetings is dependent upon the complexity of the stormwater quality issues, stormwater pollutants involved, and project site constraints. This section should be updated when permits are received; however, it is understood that some permits are received just before the Ready-to-List (RTL) date making it impractical to revise the SWDR.

Discussions that may take place to determine which permits and agreements are required include: identifying significant, unavoidable impacts to receiving waters; potential BMPs to meet a prescribed Waste Load Allocation (WLA) and TMDL for an impaired 303(d) listed water body; dewatering

requirements (some RWQCBs may require a separate dewatering permit); ADL Agreement for regulated soils; potential impacts associated with spills, especially near municipal or domestic water supply reservoirs or potable water recharge facilities; and potential impacts of unique maintenance activities or known discharges.

The required permits may include, but are not limited to, the following:

- U.S. Army Corps of Engineer Permit (404)
- U.S. Coast Guard Permit
- California Department of Fish & Wildlife (Fish and Game codes 1601/1603)
- Coastal Development Permit
- U.S. Fish and Wildlife Service approval
- National Marine Fisheries Services Permit
- RWQCB Permit (401)
- Industrial General Permit (for onsite batch plants)

401 conditions typically include requirements for additional sampling and monitoring during in-water work such as temporary clear water diversions, and restrictive work windows. The 401 summarizes impacts to waters, wetlands and other features under the RWQCB jurisdiction, and it presents the measures required to avoid, minimize, or mitigate these impacts. The conditions of the 401 are included in the Environmental Commitments Record and must be satisfied prior to acceptance of the Certificate of Environmental Compliance.

Local permits and agreements that may be required include:

- San Francisco Bay Conservation and Development Commission (BCDC) permit
- Tahoe Regional Planning Agency (TRPA) permit
- Flood control district permits
- Coastal development permit

Document relevant coordination efforts with any Municipal Separate Storm Sewer System (MS4) entities within the project limits. Reference appropriate information in the PLACs and summarize issues impacting permanent BMPs in the SWDR narrative.

6.4.7 Section 6 – Permanent BMPs

6.4.7.1 Introduction

Permanent BMPs consist of Design Pollution Prevention, Treatment, and other permanent measures that are considered or implemented to remain in place after construction is completed and must be maintained.

In some cases, these permanent BMPs will be designed to meet the requirements of other agencies, permit conditions, or other agreements. Any BMP to be included at the request of another agency should be discussed in the SWDR.

If DPP or Treatment BMPs are not deployed, then state “No [type] BMPs apply to this project.”

6.4.7.2 Design Pollution Prevention BMP Strategy

Permanent DPP BMP consideration is required for all projects with DSA and is described in Section 5. Discussion of DPP BMPs is recommended if any of the questions on Checklist DPP-1, Part 1 (Appendix A) is answered as yes. If all the questions on Checklist DPP-1, Part 1 are answered no, then discussion of DPP BMPs may not be necessary. While a discussion of DPP BMPs may not be required, all projects must incorporate certain minimum measures with respect to stormwater quality, which include the following:

- Minimize Impervious Surfaces: To reduce the volume of runoff.
- Prevent Downstream Erosion: Stormwater drainage systems will be designed to avoid downstream erosion.
- Stabilize DSA: DSA will be appropriately stabilized to prevent erosion.
- Maximize Vegetated Surfaces: To prevent erosion, promote infiltration (which reduces runoff), and remove pollutants from stormwater.

If a project includes new slopes steeper than 2:1 (h:v), then a Geotechnical Design Report should be prepared. Projects including slopes between 4:1 and 2:1 (h:v) should be coordinated with Division of Engineering Services (DES) Geotechnical Design unit.

At the PID phase, refer to Section 5 and Appendix A to consider whether DPP BMPs may be required for the project. A general discussion should be provided describing the overall DPP strategy that will be considered to protect stormwater quality and describe measures that will be further evaluated as information becomes available. The discussion should document project slopes that are steeper than 2:1 (h:v).

Desktop research or previous studies from other completed projects may be the only available information to verify slope stability concerns, drainage information, or environmentally sensitive issues that should be protected.

At the PA/ED phase, the DPP BMP strategy discussion should be developed to address stormwater quality impacts from the selected project alternative to meet permit requirements. The DPP strategy should consider downstream effects and slope protection efforts based on planned geometrics, including measures to address the finding of the RSA, if conducted. These efforts include working with the appropriate functional units, and if necessary, the PDT to consider DPP elements. A discussion of measures necessary for preservation of vegetation, soils, and ESAs should be included.

The PA/ED SWDR should be completed in consideration of and in coordination with the functional units preparing the following, applicable project-related reports:

- Water Quality Assessment Report (WQAR)
- Rapid Stability Assessment (RSA)
- Initial Site Assessment
- Technical documents to support National Environmental Policy Act (NEPA)/California Environmental Quality Act (CEQA)

At the PS&E phase, the PE is to prepare full, complete, and accurate plans, specifications, and estimates of cost for the selected DPP BMPs within the construction limits. Before starting detailed

design, the project data from the PA/ED phase should be reviewed as well as new information available from the following, applicable project-related reports:

- Drainage Report
- Rapid Stability Assessment (RSA), as applicable
- Geotechnical Design Report
- Materials Report
- Hazardous Waste Report
- Environmental Document (ED) (Completed during PA/ED process)

The PS&E documents and project-related reports must identify proposed engineering features, which includes DPP BMPs. DPP BMPs are not shown on stand-alone sheets, but are incorporated into other design elements, such as drainage or erosion control, so the discussion in the SWDR should summarize how these proposed efforts address stormwater quality concerns.

To assist with the preparation of the PS&E documents and the discussion in the SWDR, Checklists DPP-1, Parts 1-5 are provided in Appendix A. Consider using the sub-headings shown below for the type of information that could be described in the SWDR narrative. Coordination with DES Geotechnical Design unit on project slopes between 4:1 and 2:1 (h:v) should be documented at this phase.

Note that the bulleted information below may not be required or applicable to every project. Information to be included will depend on the nature of the project and the site conditions.

Downstream Effects Related to Potentially Increased Flow, Checklist DPP-1, Parts 1 and 2

- Identify any significant increase to velocity of downstream flow based on the design storm as defined in the *Highway Design Manual* (HDM) that will potentially increase scour and erosion.
- Describe Existing vs. Post Construction Conditions
- Describe channel condition and design (e.g., will the project discharge to unlined channels?)
- Identify hydraulic changes that may affect downstream channel stability (realignment, encroachment, etc.)
- Summarize RSA findings and measures proposed to address findings

Slope/Surface Protection Systems, Checklist DPP-1, Parts 1 and 3

- Describe existing and proposed slope conditions
- Describe cut and fill requirements
- Describe the permanent erosion control strategy (e.g., plants, soils, mulch, blankets, establishment periods)
- Comply with the Model Water Efficient Landscape Ordinance (MWELo) requirements per Section 6.4.7.5
- Describe how final soil stabilization will be achieved and which method will be used
- Summarize any hard surfaces (e.g., rock blankets, paving)

Concentrated Flow Conveyance Systems, Checklist DPP-1, Parts 1 and 4

- Briefly describe the Concentrated Conveyance Systems to be implemented for the project

Preservation of Existing Vegetation, Soils, and Stream Buffer Areas, Checklist DPP-1, Parts 1 and 5

- Describe area(s) of clearing and grubbing identified and defined in the contract plans
- Describe existing pre-construction practices, if any, which are already in place to reduce sediment and other pollutants in stormwater discharges. These permanent control practices may consist of rock slope protection, slope paving, engineered permanent erosion control features, including those used for post construction treatment and/or Compliance Units, and existing stormwater Treatment BMPs.
- Describe area(s) on the plans that will be placed off-limits to the contractor, if applicable (e.g., ESA areas, DPP Infiltration Areas, stream buffer areas)

The PE is to describe the DPP BMPs that are being used for TMDL CUs (stabilized areas only). Other DPP BMPs that are infiltrating stormwater and being used for post construction treatment, Alternative Compliance, or CUs will be documented under the Treatment BMP strategy section.

6.4.7.3 Treatment BMP Strategy

Discussion of Treatment BMPs is required when the Evaluation Documentation Form (EDF) concludes that treatment is required as described in Section 4. If the EDF concludes that Treatment BMPs are not required, then attach the EDF to the SWDR. However, even when treatment is not required, if DPP Infiltration Areas have been identified that could provide treatment to generate Alternative Compliance or CUs, then document this information after consultation with the District/Regional NPDES Coordinator.

If Treatment BMPs are required, Checklist T-1, Part 1 in Appendix E provides guidance on determining which Treatment BMPs to consider and should be attached to the SWDR at all phases. Once Checklist T-1, Part 1 is completed, the PE can refer to Checklist T-1, Parts 2 – 11 in Appendix B for feasibility and design considerations regarding the specific Treatment BMPs; only attach these checklists if requested.

At the PID phase, complete the EDF based on available information and anticipated project impacts. At this phase, limited information will be available related to determining if Treatment BMPs are required. The PE should review Checklist T-1, Part 1 with all available information and based on the findings of Checklist T-1, Part 1, review the Feasibility questions of Checklist T-1, Parts 2 – 11 for the BMPs considered for the project. Other considerations at the PID phase include:

- Performing a field review of area.
- Analyzing project alternatives to develop a general overview of the potential feasible BMPs for each alternative.
- A general discussion of each BMP alternative for each project alternative presented at PID. This may include the location of permanent BMPs and acquisition of RW, which is considered for funding allocation.
- The Geotechnical Design Report, Materials Report, and Drainage Report are initiated. Information from draft reports should be used when evaluating BMPs. A final report on

materials and geotechnical issues is not required at this phase, but a draft report would be appropriate.

- For projects in a TMDL watershed, the PE should project the total CUs that can potentially be generated by the project. CUs can be estimated and tracked at the PID phase and updated as the project progresses.
- BMPs must be considered as early as possible and costs developed at this phase will be used for programming purposes; consequently, the analysis should be of sufficient detail to identify all potential BMP costs to the extent necessary.

At the PA/ED phase, the PE must review and update the EDF for the selected project alternative. If Treatment BMPs are required, a discussion of the selected project alternative scope as it relates to Treatment BMPs should be included.

Decisions and actions at this phase related to Treatment BMPs include, but are not limited to, the following items:

- Determine if the scope has changed since the PID and if so, how stormwater quality issues are affected
- Evaluate potential stormwater quality impacts and options for avoiding or reducing these impacts
- Evaluate Treatment BMP applications based on the SWDR checklists and the WQAR
- Perform field review of the proposed BMP sites
- Develop calculations and supporting information for sizing Treatment BMPs and areas claiming CUs
- Identify any right of way needs for TBMP placement. Right of Way Data Sheets require preparing right of way cost estimates and cost estimate maps

The PE will coordinate with the appropriate PDT members to answer and complete Checklist T-1, Parts 1 – 11, and feasibility and design questions for the Treatment BMPs being considered for the project. These coordination efforts include:

- Providing information, such as soil types, groundwater information, side slope recommendations, slide locations, etc.; and
- Prepare base maps and plan sheets for PA&ED development and RW maps to identify areas needed for tentatively selected BMPs and their potential impacts.

If the project cannot treat the PCTA or ATA 1, then the PE, in consultation with the District/Regional NPDES Coordinator, will document a proposed alternative compliance strategy in the SWDR narrative.

At the PS&E phase, the EDF and T-1 checklists are reviewed and updated. Treatment BMPs that will be implemented as part of the project are designed. Site investigations and screening for Treatment BMPs are continued during the PS&E process as needed.

The PE is responsible for quantifying and reporting the impervious and pervious areas treated by the permanent BMPs. Projects that require Treatment BMPs must complete Tables E-1 and E-2. Districts may modify these tables based on their needs. If the District uses a modified Table E-2, the WQV or

WQF (%) Treated for each Treatment BMP must be reported since this data is not captured in the SWDR Summary Spreadsheets.

Decisions and actions at this phase related to Treatment BMPs include, but are not limited to, the following items:

- Determine if the project scope has changed since the PA/ED phase and, if so, how stormwater quality issues are affected
- Review stormwater regulations for any changes that may affect the project
- Evaluate BMP deployment strategy and design and siting criteria
- Update or revise Treatment BMP calculations and supporting information for sizing Treatment BMPs
- Perform a field review of the proposed BMP sites
- Finalize plans showing BMP deployment (e.g., Contour Grading, Drainage Plan, Erosion Control)
- Coordinate utilities - identify, pothole, protect, remove and/or relocate utility facilities as necessary to clear and certify RW for deployment of stormwater BMPs

Overall project compliance, and if applicable, Alternative Compliance (used or generated) must be documented in Section 6 of the SWDR for all projects using the E-1 and E-2 tables. Districts may modify these tables based on their needs. If the District uses a modified Table E-2, the WQV or WQF (%) treated for each Treatment BMP must be reported since this data is not captured in the SWDR Summary Spreadsheets.

The impervious and pervious areas treated within the Caltrans RW must be tracked separately from the areas treated outside of the Caltrans RW. The PE is responsible for completing the summary tables.

If it was determined during the PA/ED or PS&E phase that alternative compliance measures are required to treat the PCTA or ATA 1, then the PE shall coordinate with the District/Regional NPDES Coordinator to develop an Alternative Compliance strategy.

The PE is to develop an estimate (for internal Caltrans use only) for each individual Treatment BMP or each DPP BMP that is being used for post construction treatment or TMDL CUs. These costs will be included in the SWDR Summary Spreadsheets and/or Portal, at PS&E.

6.4.7.4 Validation of Final Soil Stabilization

Final soil stabilization of the construction site is a condition of the CGP. The CGP defines final stabilization (of soil disturbed by construction activity) to be the condition in which a project site does not pose any additional sediment discharge risk than it did prior to beginning project construction. The CGP presents three methods for demonstrating the final soil stabilization criteria stated in the CGP which are stand-alone and at the discretion of the permittee (Caltrans).

The SWDR must describe how final soil stabilization will be achieved and which method will be used. The methods are described in Section II.D3 of the CGP:

- a) "70% Final Cover Method, - no computational proof required."
- b) "RUSLE or RUSLE2 Method, - computational proof required."



- c) “Custom Method, the discharger (i.e., Caltrans) shall demonstrate in some other manner than (a) or (b), above, that the site will not pose any additional sediment risk than it did prior to the commencement of construction activity.”

To qualify for termination of permit coverage, all of the conditions listed in Conditions for Termination of Coverage in Section II.D1 of the CGP must be met. This includes the selected method, photographs, and supporting documentation.

The PE can reference the Department’s *Design Guidance for Final Soil Stabilization*, California Department of Transportation, which includes example SWDR text, at the following website:

http://www.caltrans.ca.gov/hq/oppd/stormwtr/ppdg/DG_Final-Soil-Stabilization_2016-03-18.pdf

6.4.7.5 Compliance with Model Water Efficient Landscape Ordinance (MWELo)

When MWELo applies to the project, the Landscape Architect (LA) will provide the necessary information and will use narrative to describe how the project complies with MWELo. For example, at PID and PA/ED LA may state: “The Maximum Applied Water Allowance (MAWA) and Estimated Total Water Use (ETWU) for this project will be provided at PS&E.” At PS&E LA may state: “This project complies with the Model Water Efficient Landscape Ordinance (MWELo) as it seeks to minimize erosion, limit soil compaction, minimize stormwater runoff, maximize infiltration, encourage healthy plant growth, and use irrigation water efficiently.” The MWELo Excel Worksheet, which includes all required calculations, is a Supplemental Attachment at PS&E:

<http://www.dot.ca.gov/design/lap/landscape-design/guidance.html>

For SWDRs at PS&E the LA should summarize and provide the following:

- The MWELo Excel Worksheet which includes all required calculations
- If the local water purveyor or permitting agency has requirements beyond what is required by the MWELo, describe coordination and the process to resolve any conflict

The following project conditions do not require compliance with MWELo:

- This project does not include irrigated landscape area;
- The new landscaped area is less than 500 square feet;
- The rehabilitated landscaped area is less than 2,500 square feet;
- It is an ecological restoration (habitat mitigation) project without a permanent irrigation system;
- It is an erosion control (slope repair) project without a permanent irrigation system; or
- It is a revegetation project with a temporary irrigation system.

6.4.8 Required Attachments

The required attachments of a SWDR vary upon the type and phase of project; the list of required attachments is shown in Appendix E. Required attachments that must be included for all SWDRs at all phases are a Vicinity Map, and the Evaluation Documentation Form. All other required

attachments are based on the water quality requirements of a given project. For example, in relation to the CGP, either a copy of the erosivity waiver or the risk level determination should be attached.

This section only discusses required SWDR attachments not already discussed in this Project Planning Design Guide (PPDG).

6.4.8.1 Vicinity Map of the Project Area

A vicinity map that clearly identifies the location and limits of a project should be attached to the SWDR. When available, the use of the title and location map (cover page) from the contract plans is recommended. If not shown on the cover page, or if an independent vicinity map is prepared, the following are recommended items that should be provided:

- Legend
- Begin and end work stations, and begin and end construction stations and post miles
- Project ID (EA)
- Name and flow directions of nearby creeks, streams, and rivers
- North arrow and scale
- Adjacent roads, routes or landmarks to assist in location of the project
- Name of the county, city or identification of nearest city

6.4.8.2 Stormwater Data Report (SWDR) Attachment for Stormwater Multiple Application Report Tracking System (SMARTS) Input

Projects that are required to comply with the CGP must attach the SWDR Attachment for SMARTS Input at PS&E. The information on this form will assist Department staff start the Notice of Intent (NOI) process on SMARTS. The information in this attachment summarizes the Permit Registration Documents (PRD) information in a format consistent with SMARTS; this information includes the location of the project, total DSA, changes in impervious area, risk level determination, and expected method to achieve final stabilization in compliance with the CGP. A copy of the attachment is included in Appendix E or can be downloaded from the Department's website.

6.4.9 Cost Estimating for BMPs

6.4.9.1 Project Planning Cost Estimates (PPCE) (PID and PA/ED)

The PE will typically use the Project Initiation Cost Estimate Method during the PID (and maybe the PA/ED) phase to estimate costs for stormwater related items. Depending upon the information available, the Project Design Cost Estimate Method (see 6.4.9.2) may be used at PA/ED. These costs will be used when developing the Project Planning Cost Estimate (PPCE). The project report (PR) cost estimate is prepared as part of the PA/ED process. The PR cost estimate is prepared using the same format as used to prepare the PID cost estimate; however, since the project alternative has been selected, the PPCE will be more refined. Appendix F of this document provides details on the methods for cost estimating stormwater BMPs as part of the overall project cost.

Topics to be discussed and considered during the preparation of the PPCE as it relates to stormwater related items include, but are not limited to, the following:

- Bid data from actual projects
- Sampling and Analysis Plans
- Temporary items listed and the costs for SWPPP or WPCP development and implementation
- Sensitive environments
- Highway planting contracts
- Supplemental funds
- Costs for potential stormwater BMPs
- Available cost options (see Appendix F)

The following functional units shall verify the completed PPCE: Stormwater Program Coordination, Landscape Architecture, Hydraulics, Environmental, Maintenance, and Right-of-Way.

6.4.9.2 Preliminary Engineer's Cost Estimates (PECE) (PS&E)

The PE will typically use the Project Design Cost Estimate Method during the PS&E phase to estimate costs for stormwater related items. These costs will be used when developing the Preliminary Engineer's Cost Estimates (PECE).

Preliminary Engineer's Cost Estimates (PECE) are initiated after the PR approval and are updated until completion of the PS&E process. These estimates are categorized as either preliminary or final. PECEs focus on the construction costs of the project, including stormwater BMPs, and are input into the Basic Engineering Estimating System (BEES). PECEs should be considerably more detailed than PPCEs due to the completion of engineering and other studies (environmental, geotechnical, etc.) and the availability of information, such as final contour mapping, materials and drainage information, etc. Appendix F of this document provides detail on the Project Design Cost Estimate Method to include stormwater BMPs as part of the overall project cost.

The PE and the appropriate functional units verify the completed PECE.

6.4.9.3 Incorporating Stormwater BMPs into Projects

Plans showing stormwater BMP deployment are a supplemental attachment to the SWDR. PEs are required to select and estimate stormwater BMPs when developing the PS&E package. At a minimum, designers must provide a quantity table on the Summary of Quantities sheet indicating locations or stationing of these BMPs, as part of the PS&E package. In addition, all permanent BMP used for post construction treatment or CUs shall be identified on the plans (e.g., Layout Sheets, Drainage Plans). The determination of the degree and level of detail of stormwater BMPs to be included in the contract documents should be discussed between district construction and design staff during all phases of the project. District maintenance should also be consulted when incorporating permanent BMPs.

Quantity summaries must be included in the project plans to aid in determining the location and quantities for items which are located throughout the plans. The intent of having a quantity summarized is to have one location in the plan which shows the total project quantity for an item and that total corresponds to the quantity shown in the Engineer's Estimate.

Based on the intent of the quantity summaries, items without a quantity or items which are not location specific do not need to be listed. An example of this would be a Portable Temporary Concrete Washout. Other examples would include stormwater lump sum items that are not location dependent and administrative bid items (e.g., Prepare SWPPP/WPCP, Prepare REAP, Sampling and Analysis Day, Job Site Management).

Items which represent an on-site facility (e.g., Temporary Concrete Washout, Temporary Clear Water Diversion, Temporary Active Treatment System, and Biofiltration Swale) should be included in the quantity sheets. Examples are available for Biofiltration Swales and Strips at the following website: <http://www.dot.ca.gov/hq/oppd/stormwtr/bmp-examples.htm> and demonstrate how to properly incorporate into a set of plans.

Consult the Office Engineer for additional questions regarding appropriate items for quantity sheets.

Pertinent information used to develop the stormwater BMP strategy and quantities must be provided in the Resident Engineer file and made available in the Information Handout.

6.5 Resident Engineer's (RE) File

Stormwater quality information necessary to assist the RE in understanding the design decisions for BMP use and stormwater quality related features should be readily available within the SWDR. Provide a final copy of the PS&E SWDR to Construction for inclusion in the RE File. Consult the District/Regional Design Stormwater Coordinator regarding additional information for the RE File. Provide the RE a copy of the SWDR attachment for SMARTS input form. Do not share the SWDR with the contractor.

6.6 SWDR Summary Spreadsheets

Caltrans Permit requires collecting new development and redevelopment project data at all project phases. Caltrans maintains a Portal database to track and report SWDR and Treatment BMP data as required by the Permit. The SWDR Summary Spreadsheets contain the data agreed to be collected for all Caltrans projects requiring a SWDR. Refer to the Caltrans SWDR Summary Spreadsheets User Guide¹ for additional information. See your District/Regional NPDES Coordinator to determine who is responsible to input the SWDR Summary Spreadsheets data into the Portal (refer to Implementation of Caltrans Stormwater Portal memo dated April 29, 2016).

The SWDR Summary Spreadsheets are not a required attachment to the SWDR. However, the data in the spreadsheets is required to be collected for Portal entry. Districts may use the spreadsheets to collect the data and attach to the SWDR or the District/Region may use alternate summary forms. Whatever method the District chooses the spreadsheet project data must be included in the SWDR. The District designated representative may then transfer the data to the Portal. PEs may opt to directly input the data into the Portal. If the district chooses this method, do not include the SWDR Summary Spreadsheets and include Tables E-1 and E-2 (unmodified) in the SWDR. See your District/Regional NPDES Coordinator or district policy for methodology to use. Whatever the method

¹ This document including SWDR Summary Spreadsheets can be found on the web at the following site: <http://www.dot.ca.gov/hq/oppd/stormwtr/spreadsheets.htm>

chosen, the District/Region will enter the project data into the Portal database. The data must be entered in a timely enough fashion that it is available for Annual Report and District Workplan reporting.

If Treatment BMPs are included in the project:

- It is understood that not all of the information related to Treatment BMPs can be documented at the planning phases. However, the Treatment BMP tables should be incorporated at the planning phases when data is available.
- During the PS&E phase the cost of each Treatment BMP must be included in the SWDR and entered into the Portal.
- Based upon information submitted by the PE in Tables E-1 and E-2, the District/Region, in accordance with its assigned policies, and in consultation with the PDT and project sponsor, is responsible for assigning and crediting areas treated by the project and is responsible for entering the SWDR Summary Spreadsheets project data into the Portal database².
- If a Treatment BMP is constructed in a TMDL watershed with multiple pollutants, input the Treatment BMP once on the TMT Tab of the SWDR Summary Spreadsheets and/or Portal. DEA will determine final Compliance Units.
- The PE is responsible for completing Tables E-1 and E-2, or their equivalent, and including them in the SWDR in accordance with district policy. If the district uses a modified Table E-2, the WQV or WQF (%) Treated for each Treatment BMP must be reported since this data is not captured in the SWDR Summary Spreadsheets.

² The Portal database is used for statewide treatment tracking.

**APPENDIX A: APPROVED DESIGN POLLUTION
PREVENTION BMPS AND CHECKLISTS**



THIS PAGE INTENTIONALLY LEFT BLANK.

A.1 Required Minimum Design Elements for Stormwater Control

The PE must consider, and as appropriate, incorporate certain Design Pollution Prevention (DPP) Best Management Practices (BMPs) into a project to minimize impacts to water quality. These BMPs were developed in response to the three following design objectives:

- *Prevent Downstream Erosion:* Stormwater drainage systems will be designed to avoid causing or contributing to downstream erosion;
- *Stabilize Disturbed Soil Areas (DSA):* DSA will be appropriately stabilized to prevent erosion after construction; and
- *Maximize Vegetated Surfaces Consistent with Existing Caltrans Policies:* Vegetated surfaces prevent erosion and promote infiltration (which reduces runoff).

The DPP BMP categories listed below and described in the following sections are designed to accomplish these objectives:

- Consideration of Downstream Effects Related to Potentially Increased Flow
- Preservation of Existing Vegetation
- Concentrated Flow Conveyance Systems
- Slope/Surface Protection Systems

If any project Design Pollution Prevention BMP creates concentrated flows, refer to Chapter 860 Roadside Channels of the Highway Design Manual (HDM). If velocities and shear stress exceed allowable limits for bare soil, the Project Engineer (PE) must consider channel lining (refer to Table 865.2 of the HDM). See Topics 864 and 865 of the HDM.

A.2 Consideration of Downstream Effects Related to Potentially Increased Flow

Description:

Changes in the velocity or volume of runoff, the sediment load, or other hydraulic changes from stream encroachments, crossings, or realignment may affect downstream channel stability. An estimate of the runoff coefficient based on the design storm for each watershed within the project site before and after construction should be considered (HDM, Section 800).

Caltrans will evaluate the effects of the potentially increased flow on the downstream channel stability using the Rapid Stability Assessment (RSA) approach developed (see Section 1.4.2.1). If the RSA indicates potential problems, more detailed engineering analyses are required to determine if countermeasures are needed to stabilize the crossing.

Appropriate Applications:

During the design of both new and reconstructed facilities, Caltrans may include new road surfaces or additional surface paving to enhance the operational safety and functionality of the facility. The PE must consider the effect of collecting and concentrating flows in roadside ditches, storm drain systems, or the effect of re-directing flows to Treatment BMPs. Diversions or overflows from large

storm events in these instances may create concentrated discharges in areas that have not historically received these flows.

Implementation:

If these changes result in an increased potential for downstream effects in channels, Caltrans will consider the following:

- Reduction of total paved area;
- Modifications to channel lining materials (refer to Table 865.2 of the HDM), including but not limited to vegetation, geotextile mats, and hard surfaces;
- Energy dissipation devices at culvert outlets;
- Smoothing the transition between culvert outlets/headwalls/wingwalls and channels to reduce turbulence and scour;
- Incorporating peak flow attenuation facilities into designs to reduce peak discharges;
- Modifications to site soils to improve infiltration; and
- Integration of site design principles and sustainable infrastructure, as defined in Section 5.2.

Caltrans will implement appropriate measures to ensure that runoff from Caltrans facilities will not significantly increase downstream effects.

A.3 Preservation of Existing Vegetation

Description:

Preservation of existing vegetation involves the identification and protection of desirable vegetation that provides erosion and sediment control benefits and infiltration benefits. This DPP BMP category can include existing, non-vegetated slopes that are stabilized and that provide infiltration benefits. When feasible these existing areas should be considered for use as a DPP Infiltration Area. If the area is identified as DPP Infiltration Area, it should be evaluated as treatment. See Appendix B.2.

Appropriate Applications:

Caltrans will preserve existing vegetation at areas on a site where no construction activity is planned or will occur at a later date. If the area preserved also promotes infiltration, it should be tracked and documented as treatment.

Implementation:

The following general steps should be taken to preserve existing vegetation:

- Identify and delineate in contract documents all vegetation to be retained;
- Delineate on plans the areas to be preserved in the field prior to the start of soil-disturbing activities;
- Minimize disturbed areas by locating temporary roadways to avoid stands of trees and shrubs and to follow existing contours to reduce cutting and filling;

- When removing vegetation, consider impacts (increased exposure or wind damage) to the adjacent vegetation that will be preserved: and
- Avoid grubbing when removing vegetation. Much of the native vegetation will resprout from the roots when left in place after clearing vegetation for site access.

If the preserved area promotes infiltration, track and document the area as treatment.

A.4 Concentrated Flow Conveyance Systems

Concentrated flow conveyance systems consist of permanent design measures that are used alone or in combination to intercept and divert surface flows, and convey and discharge concentrated flows with a minimum of soil erosion. Where channelized flow is required, follow the HDM.

Infiltration potential for concentrated flow conveyance systems should be considered. If the system promotes infiltration of highway runoff, it should be identified as a DPP Infiltration Area and evaluated as treatment. See Appendix B.2.

Ditches, Berms, Dikes, and Swales

Description:

These are permanent devices typically used to intercept and direct surface runoff to a drainage facility or stabilized watercourse.

Appropriate Applications:

Ditches, berms, dikes, and swales are typically implemented:

- At the top of slopes to divert run-on from adjacent slopes and areas;
- At bottom and mid-slope locations to intercept sheet flow;
- At other locations to convey concentrated flows to overside drains, stormwater drainage inlets (catch basins), pipes, stabilized watercourses, and channels;
- To intercept runoff from paved surfaces; or
- Along roadways and facilities subject to flooding.

Implementation:

- Design must be in accordance with Chapter 800 of the HDM;
- Review project conditions with the intent of removing any dike not required to meet project goals. Promote sheet flow from paved surfaces to stabilized slopes where feasible.
- Design BMPs based on careful evaluation of risks due to erosion, overtopping, and flow backups or washout;
- Consider outlet protection where localized scour is anticipated;
- Examine the site for run-on from off-site sources; and
- Consider installing and utilizing permanent dikes, swales, and ditches early in the construction process.

Ditches, berms, dikes, and swales are shown in Figure A-1.

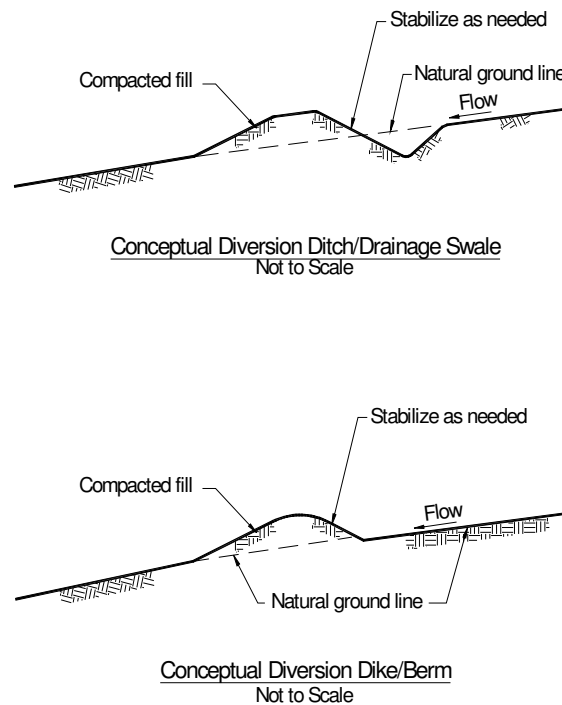

Figure A-1. Ditches, Berms, Dikes, and Swales

Note: Actual layout determined by design.

Overside Drains

Description:

Overside drains are conveyance systems used to protect slopes against erosion by collecting surface runoff from the roadbed, the tops of cuts or from benches in cut or fill slopes, and conveying it down the slope to a stabilized drainage ditch or area. Overside Drains may take the form of pipe downdrains, flumes, or paved spillways.

Appropriate Applications:

Overside drains are typically used at sites where slopes may be eroded by concentrated flows.

Implementation:

- Design must be in accordance with Chapter 830 of the HDM (see Topic 834.4);
- Paved spillways are recommended on side slopes flatter than 4:1 (h:v). On steeper slopes, pipe downdrains should be used;
- Pipe downdrains are metal pipes adaptable to any slope. They are recommended where side slopes are 4:1 (h:v) or steeper;
- Flume downdrains are rectangular corrugated metal flumes with a tapered entrance. They are best adapted for low flow rates on slopes that are 2:1 (h:v) or flatter;

- Pipe and flume downdrains shall be securely anchored to the slope; and
- Drainage from benches in cut and fill slopes should be removed at intervals ranging from 300 to 500 feet.

An overside drain is shown in the *Standard Plans*, Figure D87D.

Flared Culvert End Sections

Description:

These are devices typically placed at inlets and outlets of pipes and channels to improve the hydraulic operation, retain the embankment near pipe conveyances, and to help prevent scour and minimize erosion at these inlets and outlets.

Appropriate Applications:

Use flared culvert end sections at outlets and inlets of culverts.

Implementation:

- Design must be in accordance with Chapter 800 of the HDM (see Topics 823 through 827); and
- Use with other outlet protection/velocity dissipation devices as appropriate.

A flared culvert end section is shown in Figure A-2 (see *Standard Plans* Figures D94A and D94B); other options are shown in the *Standard Plans*.

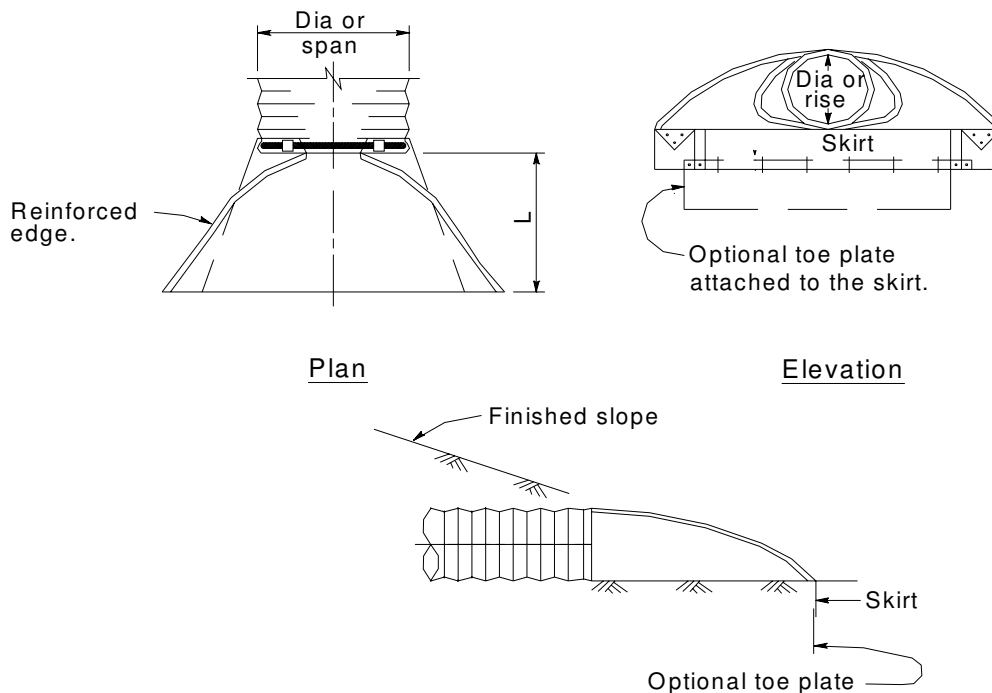

Figure A-2. Flared Culvert End Section

Outlet Protection/Velocity Dissipation Devices

Description:

These devices are typically placed at pipe outlets to reduce the velocity and/or energy of exiting stormwater flows to non-erosive levels prior to downstream discharge.

Appropriate Applications:

These devices are typically used at the outlets of pipes, drains, culverts, slope drains, diversion ditches, swales, conduits or channels, where localized scouring is anticipated.

Implementation:

- Design must be in accordance with Chapter 800 of the HDM (see Topic 827 and Chapter 870);
- Install rock slope protection, grouted rock slope protection, or concrete apron at selected outlet;
- Apron length (L) is related to outlet flow rate and tailwater level; and
- For proper operation of apron, align apron with receiving stream and keep straight throughout its length.

An example of an outlet protection/velocity dissipation device is shown in Figure A-3.

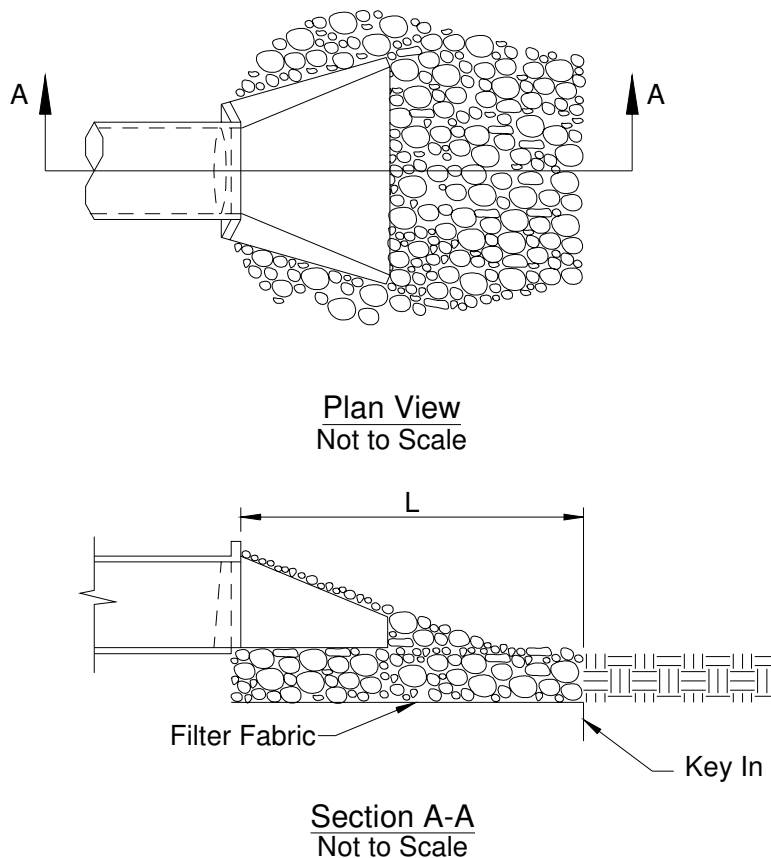

Figure A-3. Outlet Protection/Velocity Dissipation Device

A.5 Slope/Surface Protection Systems

Surface protection consists of permanent design measures that are used alone or in combination to minimize erosion from completed slopes. Vegetated surfaces may offer several advantages to paved surfaces, including lower runoff volumes and slower runoff velocities, increased times of concentration, and lower cost. However, where site or slope-specific conditions would prevent adequate establishment and maintenance of a vegetative cover, hard surfacing should be considered. When slopes are stabilized in a TMDL area, contact the District/Regional NPDES Coordinator as the stabilized area may qualify for CU credit.

Infiltration potential for project areas that incorporate vegetated surfaces, soil amendments, and hard surfaces (e.g., rock) for surface protection should be considered. If the protected area promotes infiltration of highway runoff, it may be identified as a DPP Infiltration Area and evaluated as treatment. See Appendix B.2.

Vegetated Surfaces

Description:

Vegetated surfaces should consist predominantly of established native grasses and mixed shrubs. The purpose of a vegetated surface (from a water quality perspective) is to prevent surface erosion

that can cause downstream pollution. Vegetated surfaces may additionally improve infiltration which removes sediment and may reduce pollutants in stormwater and non-stormwater runoff.

Bioengineering measures, such as soil wraps, willow planting poles, and willow fascines may be utilized as slope/surface protection measures. The measures should be coordinated with the District Landscape Architect (DLA) and District Hydraulics; applicable standard plans should also be reviewed.

Appropriate Applications:

Vegetated surfaces should be established on DSA after construction activities in that area are completed, and after the slope has been prepared. Vegetated surfaces should only be considered for areas that can support the selected vegetation long-term.

Implementation:

The following approach is typically implemented by the DLA unless otherwise noted:

- An evaluation of the site is done to determine the appropriate vegetation and planting strategy. In general, the site evaluation considers soil type and nutrient condition, site topography, climate and season, types of appropriate native and adapted vegetation suitable for the site, and maintenance;
- Vegetated surfaces are designed to provide short and long term protection of the DSA. Vegetation will minimize overland and concentrated flow depths and velocities, and maximize contact time between water and vegetated surfaces. This will enhance infiltration and pollutant removal opportunities. Shear stress and velocity calculations are the responsibility of the PE.;
- When determined feasible, existing topsoil, duff, and vegetation may be harvested and stockpiled during construction. Stockpiled materials are used to prepare DSA prior to seeding operations; and
- When topsoil and vegetation are not available, compost and mulch are a desired option. They promote seed germination and plant growth and provide surface protection.

Slope Roughening/Terracing/Rounding/Stepping:

Description:

A rough surface can be added to a slope by various methods all of which run parallel to the slope contour over the entire face of the slope. The purpose of slope roughening is to prevent surface erosion that can cause downstream pollution by reducing the velocity of surface runoff.

Appropriate Applications:

Slope roughening should be established on DSA after construction activities in that area are completed and prior to application of topsoil, where applicable. The method of slope roughening should be determined based on the steepness of the slope, the type of slope, soil characteristics, and future maintenance requirements.

APPENDIX A *Approved Design Pollution Prevention BMPs and Checklists*

Implementation:

- Roughening and terracing are techniques for creating furrows, terraces, serrations, stair-steps, or track-marks on the soil surface. These treatments increase adhesion of erosion control materials and improve vegetation establishment.
- Slope rounding is used to minimize the formation of concentrated flows; and
- Use on embankment or cut slopes, prior to the application of temporary or permanent erosion control.

Slope roughening, terracing, rounding, and stepping should be implemented as shown in Figure A-4; slope rounding is the default technique and slope roughening, terracing, and stepping can be used when slope rounding is not used.



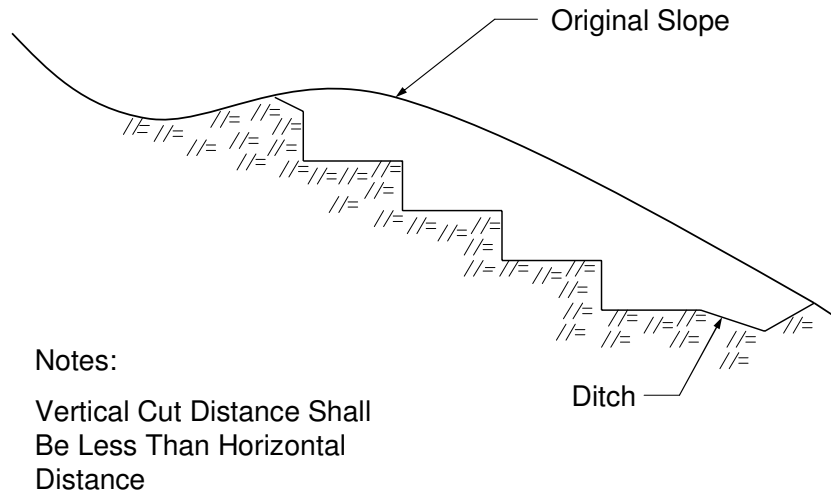

Stepped Slope (Not to Scale)

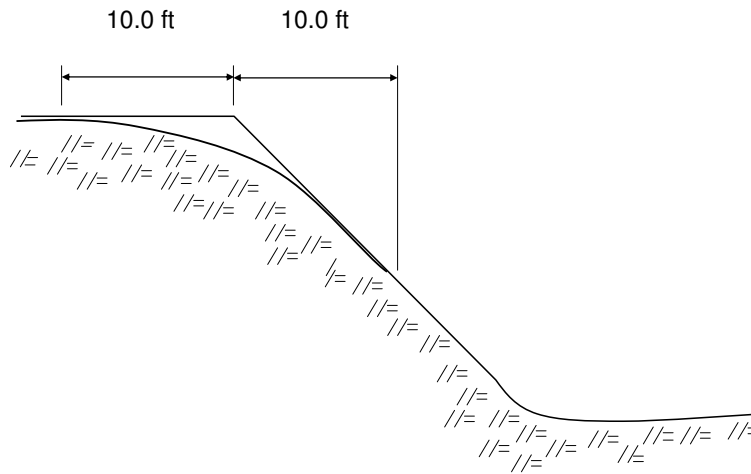

Slope Rounding

Figure A-4. Slope Rounding, Stepping, Terracing, and Contouring

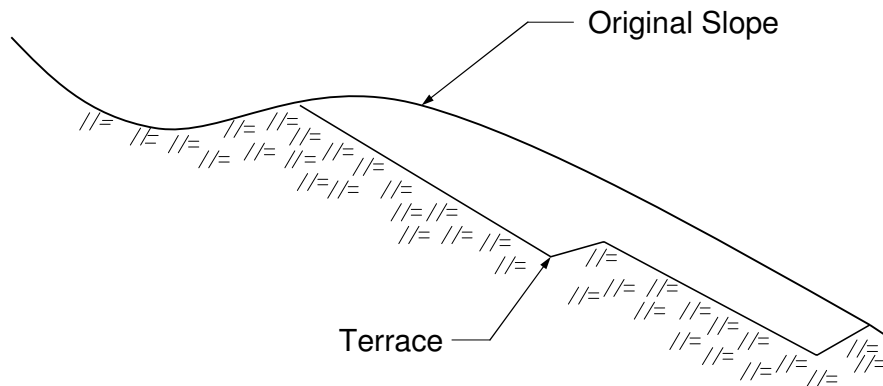

Terraced Slope (Not to Scale)



Furrow Detail

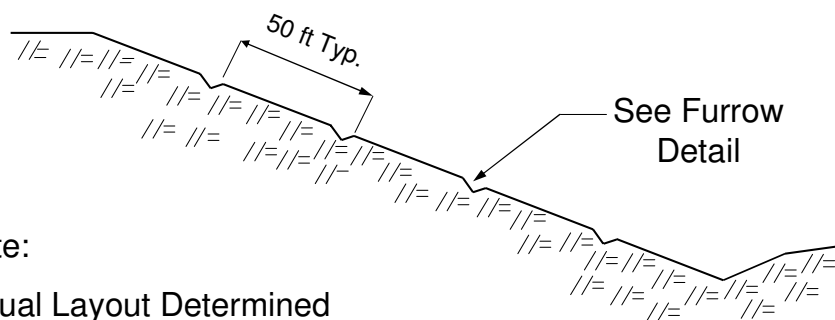

Note:
Actual Layout Determined
by Design

Contour Furrows (Not to Scale)

Figure A-4. Slope Rounding, Stepping, Terracing, and Contouring (Continued)

Hard Surfaces

Description:

Hard surfaces consist of placing concrete, rock, or rock and mortar slope protection. Vegetation may be used in conjunction with the protection system when feasible. The PE needs to consider the effects of increased runoff from impervious areas.

Appropriate Applications:

Apply on DSA where vegetation would not provide adequate erosion protection. Hard surfaces are also considered where it is difficult to maintain vegetation.

Implementation:

- Rock Slope Protection (RSP) (See the *HDM Section 870*.)
 - Angular rock of specified size is placed over fabric and used to armor slopes, streambanks, etc.;
 - RSP consists of placing revetment-type rock courses;
 - Remove loose, sharp, or extraneous material from the slope to be treated;
 - Place underlayment fabric loosely over the surface so that the fabric conforms to the surface without damage; there are fabric and other options to consider from DIB 87 to potentially promote infiltration and vegetative growth if desired. Equipment or vehicles should not be driven directly on the fabric;
 - Excavate a footing trench along the toe of the slope; and
 - Local surface irregularities should not vary from the planned slope by more than 1.0 feet (ft.) as measured at right angles to the slope.
 - Soil filled/vegetated RSP- Plant roots provide additional bio-technical reinforcement of the slope.
- Concreted RSP:
 - Angular rock of specified size is placed over fabric;
 - Concrete is placed into the rock interstices by gravity flow and a minimum of brushing and troweling; and
 - Used to armor streambanks.
- Rock Blanket:
 - Consists of round cobble rock placed as a landscape feature in areas often used for maintenance worker safety.
- Sacked Concrete Slope Protection:
 - Bags are filled with concrete mix and stacked against the slope to cure. Rebar can be driven into the wet mix and bags.
 - Used to create revetment or bank protection.

- Slope Paving:
 - Used almost exclusively below bridge decks at abutments.
 - Provides erosion control and soil stabilization in areas too dark for vegetation to establish.
 - May be constructed of finish poured Portland Cement Concrete (PCC), shotcrete, or masonry paving units.
- Articulated Revetments:
 - Mattresses composed of concrete units that are interlocked or interconnected with cables.
 - Used as channel lining or revetment.
- Gabions:
 - Wire cages filled with rock. These units are then constructed into structures of various configurations.
 - Used for channel linings and revetment.
- Turf Reinforcement Mats
 - Permanent rolled erosion control product composed of non-degradable synthetic fibers, filament, nets, wire mesh, and other materials processed into a three dimensional matrix filled with soil or rock.
 - Used for slope protection or channel lining.
- Cellular Confinement
 - Permanent rolled erosion control product composed of non-degradable, flexible honeycomb three-dimensional structure fabricated from light stabilized polyethylene plastic filled with rock.
 - Used for slope protection or channel lining.
- Vegetated Revetments

A.6 Design Pollution Prevention (DPP) BMP Checklists

Checklist DPP-1, Parts 1 – 5 are provided on the following pages to assist the PE in developing the DPP BMP strategy and completing the DPP section of the project SWDR. The checklists are provided as a tool for DPP BMP consideration purposes only. When used, the checklists should be kept in the project file, and not attached to the SWDR, unless requested by the District/Regional Design Stormwater Coordinator.

Design Pollution Prevention BMPs		
Checklist DPP-1, Part 1		
Prepared by: _____	Date: _____	District-Co-Route: _____
PM: _____	Project ID/EA: _____	RWQCB: _____

Consideration of Design Pollution Prevention BMPs

Consideration of Downstream Effects Related to Potentially Increased Flow [to streams or channels]

Will the project increase velocity or volume of downstream flow? Yes No NA

Will the project discharge to unlined channels? Yes No NA

Will the project encroach, cross, realign, or cause other hydraulic changes to a stream that may affect downstream channel stability? Yes No NA

If Yes was answered to any of the above questions, consider **Downstream Effects Related to Potentially Increased Flow**, complete the Checklist DPP-1, Part 2.

Slope/Surface Protection Systems

Will the project create new slopes or modify existing slopes? Yes No NA

If Yes was answered to the above question, consider **Slope/Surface Protection Systems**, complete the Checklist DPP-1, Part 3.

Concentrated Flow Conveyance Systems

Will the project create or modify ditches, dikes, berms, or swales? Yes No NA

Will project create new slopes or modify existing slopes? Yes No NA

Will it be necessary to direct or intercept surface runoff? Yes No NA

Will cross drains be modified? Yes No NA

If Yes was answered to any of the above questions, consider **Concentrated Flow Conveyance Systems**; complete the Checklist DPP-1, Part 4.

Preservation of Existing Vegetation, Soils, and Stream Buffer Areas

It is the goal of the Stormwater Program to maximize the protection of desirable existing vegetation, soils, and stream buffer areas to provide erosion and sediment control benefits on all projects. Complete

Consider **Preservation of Existing Vegetation, soils, and stream buffer areas**, complete the Checklist DPP-1, Part 5.

Design Pollution Prevention BMPs

Checklist DPP-1, Part 2

Prepared by: _____ Date: _____ District-Co-Route: _____

PM: _____ Project ID/EA: _____ RWQCB: _____

Downstream Effects Related to Potentially Increased Flow

1. Review total paved area and reduce to the maximum extent practicable. Complete
2. Review channel lining materials and design for stream bank erosion control. Complete
 - (a) See Chapters 860 and 870 of the HDM. Complete
 - (b) Consider channel erosion control measures within the construction limits as well as downstream. Consider scour velocity. If erosion control measures are required downstream of construction limits obtain the appropriate permits and right of way documents to include work within the construction limits. Complete
3. Include, where appropriate, energy dissipation devices at culvert outlets. Complete
4. Ensure all transitions between culvert outlets/headwalls/wingwalls and channels are smooth to reduce turbulence and scour. Complete
5. Include, if appropriate, peak flow attenuation basins or devices to reduce peak discharges. Complete
6. Calculate the water quality volume infiltrated within the project limits. These calculations will be used in the Checklist T-1, Part 1. Complete



Design Pollution Prevention BMPs		
Checklist DPP-1, Part 3		
Prepared by: _____	Date: _____	District-Co-Route: _____
PM: _____	Project ID/EA: _____	RWQCB: _____

Slope / Surface Protection Systems

1. What are the proposed areas of cut and fill? (attach plan or map) Complete
2. Were benches or terraces provided on high cut and fill slopes to shorten slope length? Yes No
3. Were concentrated flows collected in stabilized drains or channels? Yes No
4. Are new or disturbed slopes > 4:1 horizontal:vertical (h:v)? Yes No
 If Yes, District Landscape Architect is responsible for an erosion control strategy and may prepare an erosion control plan.
5. Are new or disturbed slopes > 2:1 (h:v)? Yes No
 If Yes, DES Geotechnical Design unit must prepare a Geotechnical Design Report, and the District Landscape Architect should prepare or approve an erosion control plan. Concurrence must be obtained from the District Maintenance Stormwater Coordinator for slopes steeper than 2:1 (h:v).

VEGETATED SURFACES

1. Identify existing vegetation. Complete
2. Evaluate site to determine soil types, appropriate vegetation and planting strategies. Complete
3. How long will it take for permanent vegetation to establish? Complete
4. Plan transition BMPs from construction to permanent establishment. Complete
5. Have vegetated areas and supporting permanent irrigation systems been designed to comply with the Model Water Efficient Landscape Ordinance (MWELO)? Yes No
6. Minimize overland and concentrated flow depths and velocities. Complete

HARD SURFACES

1. Are hard surfaces minimized? Yes No
 Review appropriate SSPs for Vegetated Surface and Hard Surface Protection Systems. Complete

Design Pollution Prevention BMPs

Checklist DPP-1, Part 4

Prepared by: _____ Date: _____ District-Co-Route: _____

PM: _____ Project ID/EA: _____ RWQCB: _____

Concentrated Flow Conveyance Systems

Ditches, Berms, Dikes and Swales

- 1. Consider Ditches, Berms, Dikes, and Swales as per Topics 813, 834.3, 835, and Chapter 860 of the HDM. Complete
- 2. Review existing and proposed conditions to remove any dike not required for slope stability, erosion control, and water conveyance. Complete
- 3. Evaluate risks due to erosion, overtopping, flow backups or washout. Complete
- 4. Consider outlet protection where localized scour is anticipated. Complete
- 5. Examine the site for run-on from off-site sources. Complete
- 6. Consider permissible shear and velocity when selecting lining material (See Table 865.2 in the HDM). Complete

Overside Drains

- 1. Consider downdrains, as per Index 834.4 of the HDM. Complete
- 2. Consider paved spillways for side slopes flatter than 4:1 h:v. Complete

Flared Culvert End Sections

- 1. Consider flared end sections on culvert inlets and outlets as per Chapter 827 of the HDM. Complete

Outlet Protection/Velocity Dissipation Devices

- 1. Consider outlet protection/velocity dissipation devices at outlets, including cross drains, as per Chapters 827 and 870 of the HDM. Complete

Review appropriate SSPs for Concentrated Flow Conveyance Systems. Complete

Design Pollution Prevention BMPs		
Checklist DPP-1, Part 5		
Prepared by:_____	Date:_____	District-Co-Route:_____
PM:_____	Project ID/EA:_____	RWQCB:_____

Preservation of Existing Vegetation, Soils, and Stream Buffer Areas

- 1. Review Preservation of Property, (Clearing and Grubbing) to reduce clearing and grubbing and maximize preservation of existing vegetation, soils, and stream buffer areas. Complete

- 2. Has all vegetation, soils, and stream buffer areas to be retained been coordinated with Environmental, and identified and defined in the contract plans? Yes No

- 3. Have steps been taken to minimize disturbed areas, such as locating temporary roadways to avoid stands of trees and shrubs and to follow existing contours to reduce cutting and filling? Complete

- 4. Have impacts to preserved vegetation, soils, and stream buffer areas been considered while work is occurring in disturbed areas? Yes No

- 5. Are all areas to be preserved delineated on the plans? Yes No



THIS PAGE INTENTIONALLY LEFT BLANK.

APPENDIX B: APPROVED TREATMENT BMPS AND CHECKLISTS



THIS PAGE INTENTIONALLY LEFT BLANK.

B.1 Treatment BMPs

This Appendix provides design guidelines for the Caltrans-approved Treatment Best Management Practices (BMPs) listed in Table 3-4. These BMPs have been approved for statewide use. The PE must incorporate Treatment BMPs to treat an impervious area equal to the PCTA as defined in Section 4.4 when a project has been determined by the EDF to require treatment. Treatment BMPs are considered for the project according to the following Caltrans Permit based priorities:

1. Infiltrate all runoff from impervious surfaces equivalent to the PCTA, then
2. Treat excess runoff using LID based flow-through BMPs, then
3. Treat excess runoff using Caltrans approved, or pilot, Treatment BMPs (use the Targeted Design Constituent (TDC) approach as described in Section B.1.2), then
4. If 100 percent treatment of the runoff is not achieved, develop an alternative compliance strategy.

B.1.1 Infiltration Requirements and Tools

Infiltration of runoff from impervious surfaces must be considered first. The Project Engineer (PE) is to maximize infiltration on the project unless infiltration is not recommended in the approved Geotechnical Design Report. The PE must clear site for hazardous contaminants prior to consideration of infiltration. Areas to be considered for infiltration should be identified by Project Approval/Environmental Document (PA/ED) for assessment of any environmental impacts.

The Caltrans Infiltration Tool can be used to estimate infiltration provided by specific BMPs during design. See link below for details.

<http://www.dot.ca.gov/hq/oppd/stormwtr/t1.htm>

B.1.2 Targeted Design Constituent (TDC)

A TDC is defined as a pollutant that has been identified during Departmental runoff characterization studies to be discharging with a load or concentration that commonly exceeds allowable standards and which is considered treatable by currently available Department-approved Treatment BMPs. The TDC approach is the Department's statewide design guidance to address the "Primary Pollutants of Concern." The TDC approach is used when designing Treatment BMPs.

TDCs are: phosphorus; nitrogen; total copper; dissolved copper; total lead; dissolved lead; total zinc; dissolved zinc; sediments; general metals [unspecified metals]. A project must consider treatment of identified TDCs when a water body affected by the project is 303(d) listed for one or more of these constituents. Consider using the Water Quality Planning Tool to determine these areas; this information should also be in the WOAR. Attachment IV of the Caltrans Permit includes more pollutants than are currently included as TDC's. If a pollutant of concern (POC) is not specifically listed in Section 3.2.5 or as a TDC, then when considering Treatment BMPs, use Matrix A for general purpose pollutant removal.

B.1.3 Incorporation of Existing Features as Treatment BMPs

Some existing features within the RW may be considered as Treatment BMPs even if they were not originally designed with that intent, provided that the existing features meet the criteria in these guidelines. These features (e.g., DPP Infiltration Areas, vegetated swales, detention basins) may perform the same functions as Treatment BMPs, but were not classified as Treatment BMPs at the time they were constructed. These features should be evaluated for possible classification as Treatment BMPs, considering the following:

- Determine the tributary area to the existing feature, and determine the associated water quality volume (WQV) or water quality flow (WQF);
- Verify that the Applications/Siting criteria for the Treatment BMP listed in Appendix B is met at the existing location; and
- Verify that the Design Factors of the Treatment BMP listed in Appendix B are met at the existing location.

Once these items are considered, the features that are under consideration for classification as Treatment BMPs should be discussed with the District/Regional Design Stormwater Coordinator and the entire Project Development Team (PDT). A final decision should be made after examining all the issues (e.g., water quality benefits versus changes in maintenance practices, future projects affecting the proposed Treatment BMP location).

If an existing feature is determined to be the functional equivalent of an approved Treatment BMP and classification as a Treatment BMP is accepted, then document the location in Section 6 of the Stormwater Data Report (SWDR) that this feature qualifies as a Treatment BMP and document area treated on Table E-2. Districts may use a modified table based upon their needs. See Section 6.6 for additional information.

B.1.4 Interaction with other Caltrans Functional Units

Besides Design, other functional units may play a significant role in the implementation of the various Treatment BMPs into a project. These units should be consulted during the selection and design of Treatment BMPs.

- District Landscape Architecture will select vegetative cover for many of the Treatment BMPs (e.g., biofiltration BMPs), and should be consulted on visual issues for all the Treatment BMPs.
- District Maintenance must be consulted to ensure that they can safely access and maintain the deployed Treatment BMPs.
- District Hydraulics must ensure proper hydraulic design as it is critical to the safe and efficient operation of all Treatment BMPs; this task is performed by either the PE or by District Hydraulics depending upon the district and level of complexity of the design.
- Geotechnical Services will conduct site investigations for Infiltration Devices and other Treatment BMPs.
- District Traffic Operations should be consulted when considering placement of Treatment BMPs in or near Clear Recovery Zones.
- The District Environmental Unit plays a significant role in the environmental assessment of the project and in the environmental clearance of sites for proposed Treatment BMPs.

- The District/Regional National Pollutant Discharge Elimination System (NPDES) Coordinator and/or the Design Stormwater Coordinator plays a significant role by assisting in the interpretation of the Project Planning Design Guide (PPDG), and by reviewing SWDRs produced for the Project Initiation Document (PID), Project Approval/Environmental Document (PA/ED), and Plans, Specifications, and Estimates (PS&E) phases of the project.
- District Construction will help to identify potential constructability issues with proposed Treatment BMPs.

Other units may have a role in developing appropriate Treatment BMP strategies; therefore, the PE must identify key project information and coordinate with other Functional Units throughout each project phase.

B.1.5 Hydraulic Issues Related to Treatment BMPs

Treatment BMPs are designed for water quality purposes, but they must also operate safely and effectively as part of the overall highway drainage system; because of this, hydraulic design issues must be carefully evaluated during the consideration and project development processes for Treatment BMPs, especially with regard to any upstream or downstream effects that would impact highway drainage. While some aspects of hydraulic engineering are presented in this handbook, those presented will focus on the site-specific design of a Treatment BMP, and not on all aspects of hydraulic or hydrologic engineering. Instead, the PE is referred to Section 800 of the *Highway Design Manual* (HDM), the HQ Office of Hydraulics and Stormwater Design (OHSD), and the District Hydraulics Unit (e.g., when a Treatment BMP is used for the dual purposes of peak flow attenuation and water quality treatment).

B.1.5.1 Treatment BMPs as a Component of the Drainage System

Several of the Treatment BMPs can be designed to work either online or offline.¹ There are potentially different impacts and design issues associated with online versus offline placement, and these should be discussed with District Hydraulics. Offline devices should be prioritized over online devices.

Those WQV- and WQF-based Treatment BMPs that are designed for online placement must also safely pass peak design flows. The release of larger events can be accomplished through use of a flow splitter or weir. The overflow event used in the design of the weir must be consistent with the intensity, duration, and frequency of the rainfall event used in the roadway drainage design as discussed in HDM – Topic 831.

Associated with the overflow event, a minimum freeboard of 12 inches should be provided between the surface water elevation during the overflow event and the lowest elevation of the confinement (e.g., the lowest elevation at the top of berm or vault) in order to provide assurance of the physical

¹ When placed 'online', the BMP would be located in the drainage flow path of the runoff and the BMP must convey runoff by passing all flows through the BMP itself. Flows up to the WQV (or WQF, depending upon the Treatment BMP selected) are treated by the BMP, while larger storm events are safely passed through the BMP without adversely impacting the upstream drainage systems, but without treatment. In contrast, 'offline' Treatment BMP systems primarily receive runoff from storm events up to and including the Water Quality event, while larger events are diverted around the Treatment BMP by an upstream flow splitter device.

integrity of the Treatment BMP and downstream facilities. This distance is referred to as the “freeboard” (see Topic 868 of the HDM).

B.1.5.2 Use of Peak Flow Attenuation Devices as WQV-Based Treatment BMPs

Peak attenuation devices are deployed on projects to meet the highway drainage requirements of the HDM. When deployed, they may be designed and evaluated as post construction treatment, Alternative Compliance, or CUs. Be sure to coordinate with the District Hydraulics Unit.

B.1.6 Caltrans Treatment BMP Website

For information related to all of the Caltrans approved Treatment BMPs, go to the following website:

http://www.dot.ca.gov/hq/oppd/storm1/caltrans_20090729.html

This site has guidance and tools for each Treatment BMP such as:

- Design Guidance
- Plans
- Specifications
- Animated Demonstration
- Illustrations
- Application/Siting Criteria
- Preliminary Design Factors
- BMP Capital
- Maintenance Costs
- Constituents Treated
- Effectiveness/Performance
- Design Spreadsheets
- Lessons Learned

B.2 DPP Infiltration Areas

DPP Infiltration Areas are vegetated and non-vegetated areas that have been designed or evaluated for infiltration capabilities. Pollutants are removed primarily through infiltration of surface discharge through the soil, sedimentation, and adsorption to soil particles. When vegetation is incorporated into the DPP Infiltration Area, additional pollutant removal is provided by filtration through the vegetation. If the DPP Infiltration Area includes stabilizing slopes within a TMDL area, contact the District/Regional NPDES Coordinator as the stabilized area may qualify for CU credit.

The following sections give a brief overview of DPP Infiltration Areas and a summary of design criteria.

B.2.1 Description

DPP Infiltration Areas are sized to capture the WQV, or a portion thereof, generated by the contributing drainage area. The area is calculated and used to either address the post construction treatment requirement or to generate either Alternative Compliance or Total Maximum Daily Load (TMDL) Compliance Units (CUs). A DPP Infiltration Area may be a new, modified, or existing slope, ditch, embankment, roadside area, or facility within the project limits that may be used to achieve treatment requirements. A schematic illustration of a DPP Infiltration Area is shown in Figure B-1.

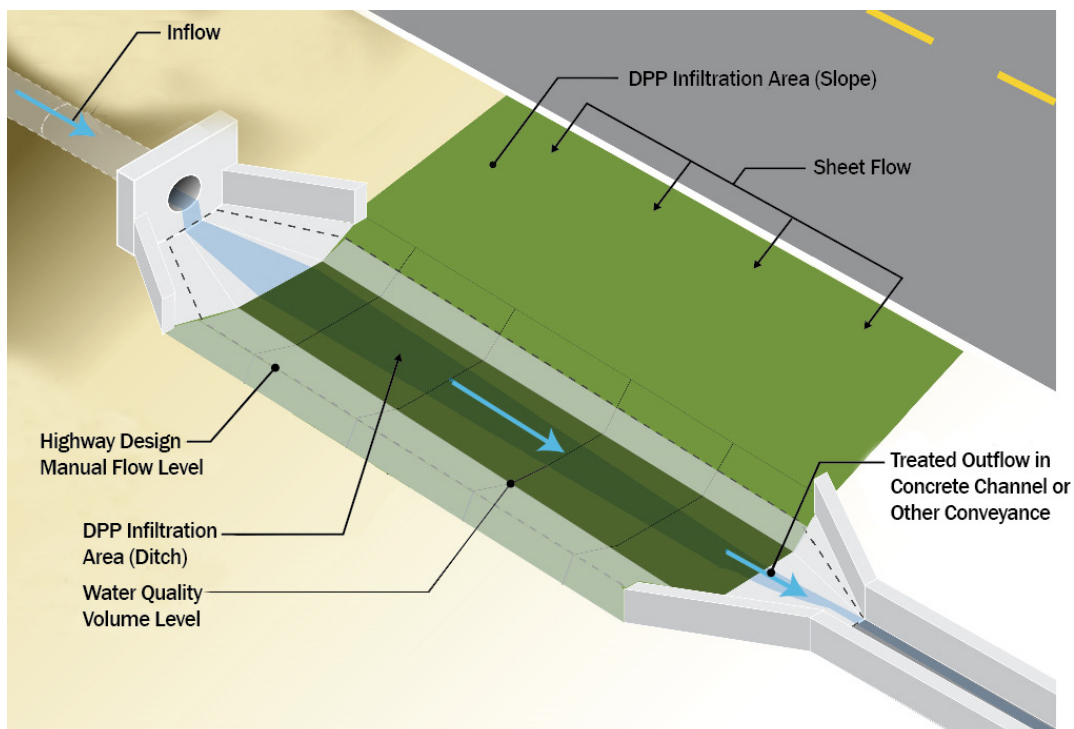

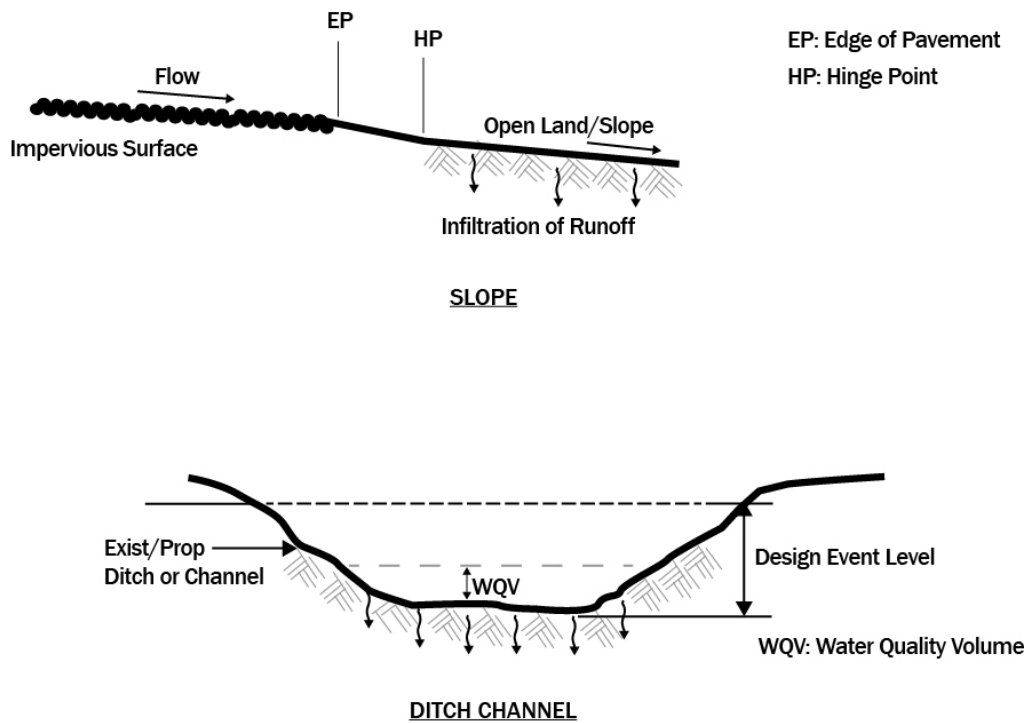

Figure B-1. Schematic of a DPP Infiltration Area

B.2.2 Appropriate Applications and Siting Criteria

DPP Infiltration Areas should be used to meet treatment objectives as described in Section 4.2 and maximize infiltration. These areas must be stabilized to prevent erosion, and are most commonly used within the pervious roadway embankment areas. DPP Infiltration Areas are not only used as a treatment mechanism for pollutants but are used to maximize infiltration and reduce discharges downstream.

B.2.3 Factors Affecting Preliminary Design

Siting and design criteria are summarized in Table B-1 below.

Table B 1. Summary of DPP Infiltration Areas Siting and Design Criteria		
Description	Applications/Siting	Preliminary Design Factors
<p>DPP Infiltration Areas are vegetated and non-vegetated land areas over which stormwater flows.</p> <p>DPP Infiltration Areas treat the WQV.</p> <p>Treatment Mechanisms:</p> <ul style="list-style-type: none"> Infiltration 	<ul style="list-style-type: none"> If proposed location is above contaminated soils or groundwater plumes, coordinate with District/Regional NPDES Coordinator and District Hazardous Waste Coordinator for direction. Sites where retention/infiltration might result in geotechnical or structural instability should be excluded 	<ul style="list-style-type: none"> Use representative infiltration or permeability rate to size the area. Design slope to prevent erosion where concentrated flows can create rills and gullies by providing appropriate protection. Consider incorporating amendments to enhance infiltration and/or climate appropriate vegetation. Consider using the Caltrans Infiltration Tool to appropriately size the BMP.

Table B 1. Summary of DPP Infiltration Areas Siting and Design Criteria		
Description	Applications/Siting	Preliminary Design Factors
Pollutants primarily removed: <ul style="list-style-type: none"> • Total Suspended Solids • Particulate Metals • Nutrients • Dissolved Metals • Turbidity 	<ul style="list-style-type: none"> • The DPP Infiltration Area should be designed to protect surface and ground water beneficial uses 	

B.2.4 Checklist

Checklist T-1, Part 11 is provided to assist the PE in evaluating the feasibility of DPP Infiltration Areas for a project, and the checklist identifies design elements that should be considered in the design of DPP Infiltration Areas. The checklist is provided as a tool and does not need to be attached to SWDR or submitted as part of the PID, PA/ED, or PS&E process.

Treatment BMPs		
Checklist T-1, Part 11		
Prepared by: _____	Date: _____	District-Co-Route: _____
PM: _____	Project ID/EA: _____	RWQCB: _____

DPP Infiltration Areas

Feasibility¹

1. Does local Basin Plan or other local ordinance provide influent limits on quality of water that can be infiltrated, and would infiltration pose a threat to groundwater quality? Yes No
2. Does infiltration at the site compromise the integrity of any slopes in the area? Yes No
 If "Yes" to any question above, DPP Infiltration Areas are not feasible; stop here and consider other approved Treatment BMPs.
3. Are DPP Infiltration Areas proposed at sites where known contaminated soils or groundwater plumes exist? Yes No
 If "Yes", consult with District/Regional NPDES Coordinator about how to proceed.
4. If adequate area cannot be obtained, document in Section 6 of the SWDR that the inability to obtain adequate area prevents the incorporation of these Treatment BMPs into the project. Complete

Design Elements

* **Required** Design Element – A "Yes" response to these questions is required to further the consideration of this BMP into the project design. Document a "No" response in Section 6 of the SWDR to describe why this Treatment BMP cannot be included into the project design.

** **Recommended** Design Element – A "Yes" response is preferred for these questions, but not required for incorporation into a project design.

1. Has native soil gradation and infiltration rate been determined (see Design Guidance for more detail)? (Must be completed for PS&E level design.) * Yes No
2. Has the infiltration rate of the DPP Infiltration Area been calculated and maximized through amendments where appropriate? ** Yes No
3. Is the DPP Infiltration Area capacity sufficient to capture the WQV, or portion thereof? ** Yes No
 If "No", document the percentage and amount of the WQV captured. Complete
4. Is a surface reinforcing material required? Yes No
 If "Yes", select material based on the permissible shear and velocity (refer to HDM Chapter 860 and Table 865.2).* Complete

¹ This feasibility evaluation is applicable to areas that are being modified for infiltration as part of the project treatment strategy. For existing areas within the project limits that are being delineated as DPP Infiltration Areas, proceed to the Design Elements section.

B.3 Infiltration Devices

An Infiltration Device is designed to remove pollutants from surface discharges by capturing the WQV, or a portion thereof, and infiltrating it directly to the soil rather than discharging it to surface waters. Infiltration devices may be configured as basins or trenches.

The following sections give a brief overview of infiltration devices and a summary of design criteria. The PE shall refer to *Caltrans Infiltration Basins Design Guidance* and *Caltrans Infiltration Trenches Design Guidance* for complete guidance on design criteria, site evaluation, and preliminary and final design.

B.3.1 Description

Infiltration Basins are a volume-based Treatment BMP that temporarily store runoff in bermed or excavated areas for infiltration over a limited period. During a storm, runoff enters the Infiltration Basin during which time the water level in the basin rises. During the rainfall, and for some time after it ends, the runoff infiltrates into the soil through the invert area, which is sized depending upon the design volume of runoff to be treated, the permeability of the soil below the invert, and the time period selected for infiltration (between 12 to 96 hours). It is preferred that events greater than the Water Quality event are bypassed around the BMP with an upstream flow splitter, but can also be passed through the BMP, typically over a spillway through the confining berm, or through an overflow riser.

Infiltration Basins may be configured in any shape to meet right-of-way (RW) restrictions, and should conform to the available space and topography, although ease of maintenance and construction should always be considered. A schematic illustration of an Infiltration Basin is shown in Figure B-2.

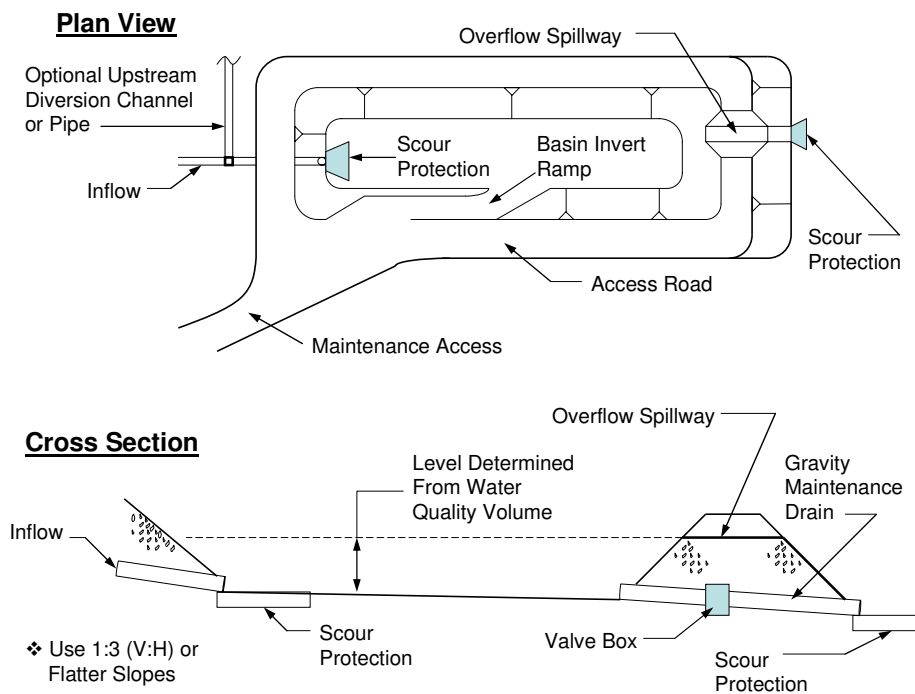

Figure B-2. Schematic of an Infiltration Basin

An Infiltration Trench utilizes relatively shallow excavations backfilled with gravel or other high porosity materials to create subsurface storage for runoff that will over a design period infiltrate into the surrounding soils. Infiltration Trenches are often elongated, allowing them to be used in constricted areas, but there is no shape restriction. A schematic illustration of an Infiltration Trench is shown in Figure B-3. While the schematic shows an installation at a non-highway facility, infiltration trenches can also be considered, as appropriate, along the highway (e.g., roadside, interchanges).

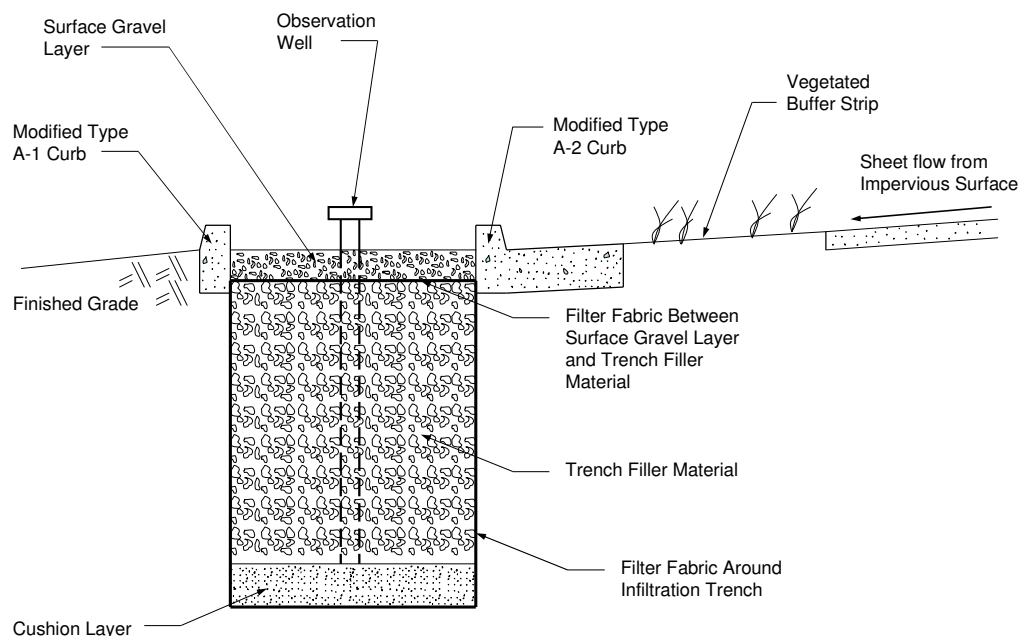

Figure B-3. Schematic of an Infiltration Trench

The WQV, or portion thereof, should be directed to the Infiltration Trench by gravity flow in an open channel or as sheet flow and the captured volume should flow downward within the trench by the action of gravity and without vertical piping for distribution to lower depths of the trench. An Infiltration Trench can also be designed to receive piped flows diverted from an underground drainage system. Flow splitters should be considered to facilitate the trench in an offline configuration.

Since infiltration trenches can be sited in circuitous alignments and sometimes implemented within a disconnected and distributed pattern, the BMP can also be considered a LID technique.

Infiltration Devices (including DPP Infiltration Areas) are considered the most effective Treatment BMP against all pollutants listed in Table 3-1. Due to the effectiveness of treatment, Infiltration is always a first choice to be considered when selecting Treatment BMPs for a Caltrans project.

B.3.2 Appropriate Applications and Siting Criteria

Infiltration Devices should be considered wherever site conditions allow. Appropriate sites for Infiltration Devices should have:

- Sufficient soil permeability;
- A sufficiently low water table;
- The influent would not present a threat to local groundwater quality; and
- Sufficient elevation to allow gravity drainage of the device when needed for maintenance purposes (Infiltration Basin only).

B.3.3 Factors Affecting Preliminary Design

Siting and design criteria are summarized in Table B-2 below.

Table B 2. Summary of Infiltration Device Siting and Design Criteria		
(Applicable to both Infiltration Basins and Infiltration Trenches unless noted)		
Description	Applications/Siting	Preliminary Design Factors
<p>Infiltration Basins are bermed or excavated areas that temporarily store runoff for infiltration.</p> <p>Infiltration Trenches utilize shallow excavations to create subsurface storage of runoff for infiltration.</p> <p>Infiltration Devices treat the WQV.</p> <p>Treatment Mechanisms:</p> <ul style="list-style-type: none"> Infiltration <p>Pollutants primarily removed:</p> <ul style="list-style-type: none"> Total Suspended Solids Particulate metals Nutrients Dissolved Metals Turbidity Mercury 	<ul style="list-style-type: none"> Runoff quality must meet or exceed standards for infiltration to local groundwater. Infiltration Devices should not be sited in locations over previously identified contaminated groundwater plumes. Separation from seasonally high water table > 5 ft., or less as justified by adequate groundwater information or RWQCB concurrence. Soil having an infiltration rate ≥ 0.5 in/hr; maximum infiltration rate is 2.5 in/hr. or greater when justified by adequate groundwater information. If significantly higher, consider the impacts to groundwater quality based on depth to seasonally high groundwater. Contact the District/Regional NPDES Coordinator to determine if consultation with the RWQCB is needed. For slower infiltrating soils, assure vector controls meet CDPH requirements. For preliminary estimates of soil infiltration rate, consult the Design Guidance. Site should not be located in areas containing fractured rock within 10 ft of invert. Locate where sloping ground < 15 percent, and where infiltrated water is unlikely to affect the stability down gradient of structures, slopes, or embankments. Locate at least 1,000 ft from any municipal water supply well; at least 100 ft from any private well, septic tank or drain field; and at least 200 ft from a Holocene fault zone. Locate > 10 ft down gradient and 100 ft up gradient from structural foundations, when infiltrating to near surface groundwater. Infiltration Trenches: installed down gradient from the highway structural section, and should not be placed closer horizontally than the Trench depth to the roadway if in a location subject to frost. 	<ul style="list-style-type: none"> Infiltration Basins and Infiltration Trenches: Infiltrate WQV, or portion thereof within a maximum of 96 hours. Longer drawdown times may be allowable if vector controls have been implemented (e.g., underground, flap gates) When considering longer drawdown times, coordinate with the District/Regional Design Stormwater Coordinator. Use representative infiltration or permeability rate to size the device Provide maintenance access: For an Infiltration Basin, provide a road entirely around the basin or at least to the overflow spillway and a ramp to the basin invert. Provide an access road to an Infiltration Trench. Infiltration Devices should not be placed in service within a construction contract until all upstream runoff is stabilized, or shall be protected from sediment-laden runoff. Infiltration Basins: Provide an upstream diversion channel or pipe for storm events > WQV, if feasible, as part of the Basin flow control device sized to pass the peak drainage facility design event (see HDM Chapter 830). If upstream diversion is not feasible, a downstream overflow outlet must be sized to pass the peak drainage facility design event. Overflow outlet can be either an outlet riser, spillway, or overflow weir. See design guidance for minimum sizing. Infiltration Basins: Provide a minimum 12 inch freeboard (the difference between the surface water elevation during the overflow event and the lowest elevation of the confinement) Infiltration Basin: Scour protection on inflow and overflow outlet Infiltration Basins: Use as flat an invert as possible (3 percent maximum); Infiltration Trenches: flat invert (no slope) Infiltration Basins: Provide maintenance gravity drain, minimum 8-inch, if practicable Infiltration Basins: Use 4:1 (H:V) side slope ratios or flatter for interior side slopes, unless approved by District Maintenance, with 3:1 (H:V) maximum Infiltration Basins: Provide vegetation, typically grasses at invert and side slopes. Infiltration Trenches: Provide one observation well in the Trench, minimum diameter of 4 inches, with weatherproof cap; may be used to drain the trench if necessary. Infiltration Trenches: Maximum depth of trench is 13 feet and WQV should be directed to trench as surface flow or underground drainage system, and allowed to gravity-flow downward to the invert of the trench. Pretreatment to capture sediment in the runoff (such as with vegetation, a flow splitter with sump, forebay, etc.): required

Table B 2. Summary of Infiltration Device Siting and Design Criteria		
(Applicable to both Infiltration Basins and Infiltration Trenches unless noted)		
Description	Applications/Siting	Preliminary Design Factors
	<ul style="list-style-type: none"> • Infiltration Trenches: would likely be considered inappropriate for placement in close proximity to a Drinking Water Reservoir and/or Recharge Facility due to the difficulty in cleaning in the event of a spill; consult District/Regional NPDES Coordinator if an Infiltration Trench is being considered in close proximity to a Drinking Water Reservoir and/or Recharge Facility. • Locate outside the Clear Recovery Zone (HDM Topic 309.1), or design to be traversable, or consult with Traffic Operations to determine if guard railing is required. 	<ul style="list-style-type: none"> • for Infiltration Trenches, and recommended for Infiltration Basins. • Infiltration Trenches located in non highway facilities often have a perimeter curb for delineation, and to limit vehicle wheel loads from encroaching upon the trench.

Specifications for permeable material to be used in Infiltration Trenches can be downloaded from the OHSD Treatment BMPs guidance website.

B.3.4 Checklist

Checklist T-1, Part 2 is provided to assist the PE in evaluating the feasibility of infiltration devices for a project, and the checklist identifies design elements that should be considered in the design of infiltration devices. The checklist is provided as a tool and does not need to be attached to SWDR or submitted as part of the PID, PA/ED, or PS&E process.

Treatment BMPs		
Checklist T-1, Part 2		
Prepared by: _____	Date: _____	District-Co-Route: _____
PM: _____	Project ID/EA: _____	RWQCB: _____

Infiltration Devices

Feasibility

1. Does local Basin Plan or other local ordinance provide influent limits on quality of water that can be infiltrated, and would infiltration pose a threat to groundwater quality? Yes No
2. Does infiltration at the site compromise the integrity of any slopes in the area? Yes No
3. Is site located over a previously identified contaminated groundwater plume? Yes No

If “Yes” to any question above, Infiltration Devices are not feasible; stop here and consider other approved Treatment BMPs.
4. At the invert, does the soil type classify as NRCS Hydrologic Soil Group (HSG) D, or does the soil have an infiltration rate < 0.5 inches/hr? Yes No

If “Yes”, the location can only be considered if vector control has been addressed (e.g., underground).
5. (a) Does site have groundwater within 5 ft of basin invert? Yes No
 (b) Does site investigation indicate that the infiltration rate is significantly greater than 2.5 inches/hr? Yes No

If “Yes” to either part of Question 5, adequate groundwater information must be available or contact RWQCB for concurrence before approving the site for infiltration.
6. Does adequate area exist within the RW to place Infiltration Device(s)? Yes No

If “Yes”, continue to Design Elements sections. If “No”, continue to Question 7.
7. If adequate area does not exist within RW, can suitable, additional RW be acquired to site Infiltration Devices and how much RW would be needed to treat WQV, or a portion thereof? _____ acres Yes No

If Yes, continue to Design Elements section.
 If No, continue to Question 8.
8. If adequate area cannot be obtained, document in Section 6 of the SWDR that the inability to obtain adequate area prevents the incorporation of this Treatment BMP into the project. Complete

Design Elements – Infiltration Basin

* **Required** Design Element – A “Yes” response to these questions is required to further the consideration of this BMP into the project design. Document a “No” response in Section 6 of the SWDR to describe why this Treatment BMP cannot be included into the project design.

** **Recommended** Design Element – A “Yes” response is preferred for these questions, but not required for incorporation into a project design.

- 1. Has an investigation been conducted, including subsurface soil investigation, in-hole conductivity testing and groundwater elevation determination? (This report must be completed for PS&E level design.) * Yes No
- 2. Has an upstream bypass or overflow spillway with scour protection been provided? * Yes No
- 3. Is the Infiltration Basin size sufficient to capture the WQV, or portion thereof, with a maximum 96-hour drawdown time? Longer drawdown times may be allowable if vector controls have been implemented (e.g., underground chamber with flap gates) and coordinated with the District/Regional Design Stormwater Coordinator.* Yes No
- 4. Can access be provided to the invert of the Infiltration Basin? * Yes No
- 5. Can the Infiltration Basin accommodate the freeboard above the overflow event elevation (reference Appendix B.1.5.1)? * Yes No
- 6. Can the Infiltration Basin be designed with interior side slopes no steeper than 4:1 (h:v) (may be 3:1 [h:v] with approval by District Maintenance)? * Yes No
- 7. Can vegetation be established in an earthen basin at the invert and on the side slopes for erosion control and to minimize re-suspension? If No, consider rock or similar protective system. Note: Infiltration Basins may be lined, in which case no vegetation would be required for lined areas.** Yes No
- 8. Can diversion be designed, constructed, and maintained to bypass flows exceeding the WQV? ** Yes No
- 9. Can a gravity-fed maintenance drain be placed? ** Yes No

Design Elements – Infiltration Trench

- 1. Has an investigation been conducted, including subsurface soil investigation, in-hole conductivity testing and groundwater elevation determination? (This report must be completed for PS&E level design.) * Yes No
- 2. Is the surrounding soil within Hydrologic Soil Groups (HSG) Types A, B, and C while preserving an acceptable infiltration rate? * Yes No
- 3. Is the Infiltration Trench size sufficient to capture the WQV, or portion thereof, with a maximum 96-hour drawdown time? Longer drawdown times may be allowable, coordinate with the District/Regional Design Stormwater Coordinator.* Yes No
- 4. Is the depth of the Infiltration Trench ≤ 13 ft? * Yes No
- 5. Can an observation well be placed in the trench? ** Yes No
- 6. Can access be provided to the Infiltration Trench? * Yes No
- 7. Can pretreatment be provided to capture sediment in the runoff (such as using vegetation or a flow splitter with a sump)? ** Yes No
- 8. Can flow diversion be designed, constructed, and maintained to bypass flows exceeding the Water Quality event? ** Yes No
- 9. Does a perimeter curb or similar device need to be provided (to limit wheel loads upon the trench)? ** Yes No

B.4 Biofiltration Strips and Swales (Vegetated Treatment Systems)

Biofiltration Strips are vegetated land areas, over which stormwater flows as sheet flow. Biofiltration Swales are vegetated channels, typically configured as trapezoidal or v-shaped channels that receive and convey stormwater flows while meeting water quality criteria and other flow criteria.

Pollutants are removed by filtration through the vegetation, sedimentation, adsorption to soil particles, and infiltration through the soil. Strips and swales are most effective at reducing Total Suspended Solids (soil particles) and particulate metals. In most cases, biofiltration swales and strips can also be considered a LID technique.

The following sections give a brief overview of biofiltration devices and a summary of design criteria. The PE shall refer to *Caltrans Biofiltration Swale Design Guidance* and *Caltrans Biofiltration Strips Design Guidance* for complete guidance on design criteria, site evaluation, and preliminary and final design.

B.4.1 Description

Biofiltration Strips are sloped vegetated land areas located adjacent to impervious areas, over which stormwater runoff flows as sheet flow. Pollutants are removed by filtration through the vegetation, uptake by plant biomass, sedimentation, adsorption to soil particles, and infiltration through the soil. Biofiltration Swales are vegetated, typically trapezoidal channels, which receive and convey stormwater flows while meeting water quality criteria and other flow criteria. Pollutants are removed by filtration through the vegetation, uptake by plant biomass, sedimentation, adsorption to soil particles, and infiltration through the soil.

When properly implemented, biofiltration strips and swales are aesthetically pleasing.

B.4.2 Appropriate Applications and Siting Criteria

Biofiltration Strips and Swales should be considered wherever site conditions and climate allow vegetation to be established and where flow velocities will not cause scour. A minimum vegetative cover of approximately 65 percent is required for treatment to occur. Biofiltration Strips and Swales are one of several BMPs for treatment of stormwater runoff from project areas that are anticipated to produce pollutants of concern (e.g., roadways, parking lots, maintenance facilities).

These devices are well suited to be part of a treatment-train system of BMPs and should be considered whenever siting other BMPs that could benefit from pretreatment, especially Infiltration Basins and Infiltration Trenches. When used as pretreatment, the amount of runoff infiltrated by Biofiltration Devices should be calculated and documented.

B.4.3 Factors Affecting Design

Table B-3 summarizes preliminary design factors for Biofiltration Strips and Swales.

Table B 3. Summary of Biofiltration Strips and Swales Siting and Design Factors		
Description	Applications/Siting	Preliminary Design Factors
<p>Biofiltration Strips are vegetated land areas over which stormwater flows as sheet flow.</p> <p>Biofiltration Swales are vegetated channels that receive and convey stormwater as a concentrated flow.</p> <p>Biofiltration treats the WQF.</p> <p>Treatment Mechanisms:</p> <ul style="list-style-type: none"> • Filtration through the vegetation • Sedimentation • Adsorption to soil particles • Infiltration <p>Pollutants primarily removed:</p> <ul style="list-style-type: none"> • Total Suspended Solids • Particulate metals • Nutrients • Dissolved Metals • Turbidity 	<ul style="list-style-type: none"> • Site conditions and climate allow vegetation to be established – approximate 65 percent vegetation coverage will allow treatment, with better effects at higher coverage • Consider locations for swales where flow velocities will not cause scour • If proposed location is above contaminated soils or groundwater plumes, coordinate with District/Regional NPDES Coordinator and District Hazardous Waste Coordinator for clear direction 	<ul style="list-style-type: none"> • Strips and Swales: vegetation mix appropriate for climates and location • Strips and Swales: Use the Rational Method to determine the WQF and the peak discharge from the highway drainage design storm event. • Strips and Swales: select lining material based on HDM Chapter 860. Refer to Table 865.2. • Swales: design as a conveyance system for the peak drainage facility design event per HDM Chapters 800 to 890. • Swales: after designing to convey flows from the peak drainage facility design event, check swale against biofiltration criteria at WQF. • Swales: design criteria under WQF: Hydraulic Residence Time of 5 minutes or more; maximum velocity of 1.0 ft/s; and maximum depth of flow of 0.5 ft. • Swales: slope in direction of flow: minimum 0.25 percent, maximum 6 percent, with 1 to 2 percent preferred; • Swales: A minimum width (in the direction of flow) at the invert of a trapezoidal biofiltration swale typically 2.0 ft; maximum bottom typically up to 10 ft; side slope ratio should be 4:1 (H:V) or flatter; discuss bottom width and side slope ratio with District Maintenance. Non trapezoidal swales are allowed, consult Hydraulics and Maintenance. • Swales: freeboard: Refer to HDM Topic 868 to determine if freeboard is required. • Strips: sized as long (in direction of flow) and flat as the site will reasonably allow up to sheet flow boundaries (maximum length of Biofiltration Strip is approximately 100 ft); a Hydraulic Residence Time is not required. • Strips: slope in the direction of flow: minimum must grade to drain, maximum must support required vegetation. 4H:1V or flatter is preferred, however strip slopes up to 2H:1V have shown pollutant removal. • Strips: should be free of gullies or rills

B.4.4 Checklist

Checklist T-1, Part 3 is provided to assist the PE in evaluating the feasibility of biofiltration devices for a project, and the checklist identifies design elements that should be considered in the design of biofiltration devices. The checklist is provided as a tool and does not need to be attached to SWDR or submitted as part of the PID, PA/ED, or PS&E process.

Treatment BMPs		
Checklist T-1, Part 3		
Prepared by: _____	Date: _____	District-Co-Route: _____
PM: _____	Project ID/EA: _____	RWQCB: _____

Biofiltration Swales / Biofiltration Strips

Feasibility

1. Do the climate and site conditions allow vegetation to be established? Yes No
 If "No", evaluate other BMPs.

2. Can biofiltration swale be designed with a slope between 0.25 and 6 percent (with 1 to 2 percent preferred)? Yes No
 If "No", Biofiltration Swales are not feasible.

3. Can biofiltration strips be designed with a maximum slope of 2H:1V (with 4H:1V or flatter preferred)? Yes No
 If "No", Biofiltration Strips are not feasible.

4. Are Biofiltration device(s) proposed at sites where known contaminated soils exist? Yes No
 If "Yes", consult with District/Regional NPDES Coordinator about how to proceed.

5. Does adequate area exist within the RW to place Biofiltration device(s)? Yes No
 If "Yes", continue to Design Elements section. If "No", continue to Question 6.

6. If adequate area does not exist within RW, can suitable, additional RW be acquired to site Biofiltration devices and how much RW would be needed to treat WQF?
 _____ acres Yes No
 If "Yes", continue to Design Elements section. If "No", continue to Question 7.

7. If adequate area cannot be obtained, document in Section 6 of the SWDR that the inability to obtain adequate area prevents the incorporation of these Treatment BMPs into the project. Complete

Design Elements

* **Required** Design Element – A “Yes” response to these questions is required to further the consideration of this BMP into the project design. Document a “No” response in Section 6 of the SWDR to describe why this Treatment BMP cannot be included into the project design.

** **Recommended** Design Element – A “Yes” response is preferred for these questions, but not required for incorporation into a project design.

- | | | | |
|----|--|------------------------------|-----------------------------|
| 1. | Has the District Landscape Architect provided vegetation mixes appropriate for climate and location? * | <input type="checkbox"/> Yes | <input type="checkbox"/> No |
| 2. | Can the biofiltration swale be designed as a conveyance system under any expected flows > the WQF event, as per HDM Chapter 800? * (e.g., freeboard, minimum slope) | <input type="checkbox"/> Yes | <input type="checkbox"/> No |
| 3. | Can the biofiltration swale be designed as a water quality treatment device under the WQF while meeting the required HRT, depth, and velocity criteria? (Reference Appendix B, Section B.4.3)* | <input type="checkbox"/> Yes | <input type="checkbox"/> No |
| 4. | Is the maximum length of a biofiltration strip ≤ 100 ft? Strips > 100 ft. may still be considered as long as potential erosion issues have been addressed. ** | <input type="checkbox"/> Yes | <input type="checkbox"/> No |
| 5. | Has the minimum width (perpendicular to flow) of the invert of the biofiltration swale received the concurrence of District Maintenance? * | <input type="checkbox"/> Yes | <input type="checkbox"/> No |
| 6. | Can biofiltration swales be located in natural or low cut sections to reduce maintenance problems caused by animals burrowing through the berm of the swale? * | <input type="checkbox"/> Yes | <input type="checkbox"/> No |
| 7. | Has the infiltration rate of the bio-filtration device been calculated and maximized through amendments where appropriate? ** | <input type="checkbox"/> Yes | <input type="checkbox"/> No |
| 8. | Have Biofiltration Systems been considered for locations upstream of other Treatment BMPs, as part of a treatment train or pretreatment? ** | <input type="checkbox"/> Yes | <input type="checkbox"/> No |
| | If “Yes”, document the amount of runoff treated (WQV/WQF). | | |
| 9. | Has the lining material been selected based on the permissible shear and velocity (refer to HDM Chapter 860 and Table 865.2)?* | <input type="checkbox"/> Yes | <input type="checkbox"/> No |

B.5 Detention Devices

A Detention Device is a volume-based permanent Treatment BMP designed to reduce the sediment and particulate loading in runoff from the water quality design storm. While the WQV, or portion thereof, is temporarily detained in the device sediment and particulates settle out under the quiescent conditions prior to the runoff being discharged. A Detention Device is typically configured as a basin.

Detention Basins can remove litter, settleable solids, total suspended solids, particulate metals, and sorbed pollutants such as heavy metals, oil, and grease by capturing, temporarily detaining, and gradually releasing stormwater runoff.

The following sections give a brief overview of detention devices and a summary of design criteria. The PE shall refer to *Caltrans Detention Basins Design Guidance* for complete guidance on design criteria, site evaluation, and preliminary and final design.

B.5.1 Description

Detention Basins operate by intercepting runoff and detaining it long enough for the sediment and particulates to settle out under quiescent conditions prior to the runoff being discharged. Detention Basins are typically designed to completely drain after a storm event, and are normally dry between rain events. Detention Basins are designed for water quality purposes but they must also operate safely and effectively as part of the overall highway drainage system. Detention Basins must safely pass the peak drainage facility design event in accordance with the HDM.

In addition, Detention Basins should be able to operate by gravity flow while limiting clogging of the water quality outlet and providing a proper overflow spillway or overflow riser for larger runoff volumes. The basins should only require occasional maintenance and cleaning. Entering flows should be distributed uniformly at low velocity to prevent re-suspension of settled materials and to encourage quiescent conditions. Low flow channels are often used to ensure conveyance to the outlet and to limit erosion. Basin shape and/or configuration should result in as natural an appearance as possible.

B.5.2 Appropriate Applications and Siting Criteria

Detention Devices and other approved Treatment BMPs should be considered for implementation wherever Infiltration Devices are not feasible. Refer to Checklist T-1, Part 1. See Table B-4 for siting and design criteria.

Sufficient hydraulic head should be available so that water stored in the device does not cause an objectionable backwater condition in the upstream storm drain system. The seasonally high groundwater should be at least 5 ft below the invert of the Detention Basin (less with approval from RWQCB) unless a liner is used.

B.5.3 Factors Affecting Preliminary Design

Preliminary design factors for Detention Devices are summarized in Table B-4. A Detention Device designed for dual purposes of water quality and attenuation of peak flows requires additional design considerations not included in this table.

Table B 4. Summary of Detention Device Siting and Design Criteria

Description	Applications/Siting	Preliminary Design Factors
<p>Impoundments where the WQV is temporarily detained during treatment</p> <p>Treatment Mechanisms:</p> <ul style="list-style-type: none"> • Sedimentation • Infiltration (if basin unlined) <p>Pollutants primarily removed:</p> <ul style="list-style-type: none"> • Sediment (TSS) • Particulate metals • Litter • Sorbed pollutants (heavy metals, oil and grease [O&G]) to some degree 	<ul style="list-style-type: none"> • Sufficient head to prevent objectionable backwater condition in the storm drain system • Separation from seasonally high water table > 5 ft, or less as justified by adequate groundwater information or RWQCB concurrence (if liner not used) • Use liner if basin is located over a known contaminated groundwater plume unless approved by the local RWQCB due to the presence of low permeability soils (Hydrologic Soil Groups C or D) • If significant sediment is expected (e.g., from erosion-prone cut slopes) consider increasing the volume of the Detention Device an amount equivalent to the annual loading (or more, if less frequent cleanout is expected); consult with District Maintenance. Consider a sediment trap or forebay. Refer to <i>Caltrans Traction Sand Traps Design Guidance</i> (Section 1.2.2 Loading Dock and 1.2.3 Earthen Berm) • Locate outside the Clear Recovery Zone (HDM Topic 309.1), design to be traversable, or consult with Traffic Operations to determine if guard railing is required 	<ul style="list-style-type: none"> • Size to capture the WQV, or portion thereof, according to Section 5.3.3 • Outlet designed to empty device within a maximum of 96 hrs. (consistent with device sizing method), with 40 to 48-hrs recommended, using debris screen (or equivalent) • Minimum water quality outlet orifice size of 0.5 in. • Flow-path-to-width ratio of at least 2:1 recommended. • Maintenance access (road around device and ramp to basin invert) • Provide an upstream diversion channel or pipe for storm events > WQV, if feasible, as part of the Basin flow control device sized to pass the peak drainage facility design event (see HDM Chapter 830). If upstream diversion is not feasible, a downstream overflow outlet must be sized to pass the peak drainage facility design event. Overflow outlet can be either an outlet riser, spillway, or overflow weir. See design guidance for minimum sizing. • Provide freeboard ≥ 12 inches (distance between the elevation of water in the basin when passing the design storm and the elevation at the top of the confinement). • Provide a maintenance gravity drain. Use 8-inch diameter pipe for gravity drain; connect gravity drain to base of outlet riser • Flows should enter at low velocity. Use scour protection on inflow, outfall and spillway if necessary • If a vegetated invert is used, consider adding a low-flow channel between the influent pipe and the outlet device, to reduce erosion. • Use 4:1 (H:V) slope ratios or flatter for interior slopes, unless approved by District Maintenance, with 3:1 (h:v) maximum • Provide vegetation on (earthen) invert and on non-paved side slopes.

B.5.4 Checklist

Checklist T-1, Part 4 is provided to assist the PE in evaluating the feasibility of detention devices for a project, and the checklist identifies design elements that should be considered in the design of detention devices. The checklist is provided as a tool and does not need to be attached to SWDR or submitted as part of the PID, PA/ED, or PS&E process.

Treatment BMPs		
Checklist T-1, Part 4		
Prepared by: _____	Date: _____	District-Co-Route: _____
PM: _____	Project ID/EA: _____	RWQCB: _____

Detention Devices

Feasibility

1. Is there sufficient head to prevent objectionable backwater conditions in the upstream drainage systems? Yes No

2. Is basin invert \geq 5 ft above seasonally high groundwater or can it be designed with an impermeable liner? (Note: If an impermeable liner is used, the seasonally high groundwater elevation must not encroach within 12 inches of the invert.) Yes No
 If No to any question above, then Detention Devices are not feasible.

3. If the Detention Device is being used to capture traction sand, is the total volume of the device at least equal to the WQV designed to be treated plus the anticipated volume of traction sand, while maintaining a minimum 12-inch freeboard (1 ft)? Yes No
 If No, then Detention Devices are not feasible.

4. Does adequate area exist within the RW to place Detention Device? Yes No
 If Yes, continue to the Design Elements section. If No, continue to Question 5.

5. If adequate area does not exist within RW, can suitable, additional RW be acquired to site Detention Device and how much RW would be needed to treat WQV? _____ acres Yes No
 If Yes, continue to the Design Elements section. If No, continue to Question 6.

6. If adequate area cannot be obtained, document in Section 6 of the SWDR that the inability to obtain adequate area prevents the incorporation of this Treatment BMP into the project. Complete

Design Elements

* **Required** Design Element – A “Yes” response to these questions is required to further the consideration of this BMP into the project design. Document a “No” response in Section 6 of the SWDR to describe why this Treatment BMP cannot be included into the project design.

** **Recommended** Design Element – A “Yes” response is preferred for these questions, but not required for incorporation into a project design.

- | | | |
|---|------------------------------|-----------------------------|
| 1. Has the location of the Detention Device been evaluated for any effects to the adjacent roadway and subgrade? * | <input type="checkbox"/> Yes | <input type="checkbox"/> No |
| 2. Can a minimum freeboard of 12 inches be provided above the overflow event elevation? * | <input type="checkbox"/> Yes | <input type="checkbox"/> No |
| 3. Is an upstream bypass or overflow outlet provided? * | <input type="checkbox"/> Yes | <input type="checkbox"/> No |
| 4. Is the drawdown time of the Detention Device a maximum of 96 hours? * | <input type="checkbox"/> Yes | <input type="checkbox"/> No |
| 5. Is the basin outlet designed to minimize clogging (minimum outlet orifice diameter of 0.5 inches)? * | <input type="checkbox"/> Yes | <input type="checkbox"/> No |
| 6. Are the inlet and outlet structures designed to prevent scour and re-suspension of settled materials, and to enhance quiescent conditions? * | <input type="checkbox"/> Yes | <input type="checkbox"/> No |
| 7. Can vegetation be established in an earthen basin at the invert and on the side slopes for erosion control and to minimize re-suspension? Otherwise include rock or similar protective system. Note: Detention Basins may be lined, in which case no vegetation would be required for lined areas. * | <input type="checkbox"/> Yes | <input type="checkbox"/> No |
| 8. Has sufficient access for maintenance been provided? * | <input type="checkbox"/> Yes | <input type="checkbox"/> No |
| 9. Is the side slope 4:1 (h:v) or flatter for interior slopes? **
(Note: Side slopes up to 3:1 (h:v) allowed with approval by District Maintenance.) | <input type="checkbox"/> Yes | <input type="checkbox"/> No |
| 10. If significant sediment is expected from nearby slopes, can the Detention Device be designed with additional volume equal to the expected annual loading? ** | <input type="checkbox"/> Yes | <input type="checkbox"/> No |
| 11. Is flow path as long as possible (> 2:1 length to width ratio at WQV elevation is recommended)? ** | <input type="checkbox"/> Yes | <input type="checkbox"/> No |

B.6 Traction Sand Traps (TST)

Traction Sand Traps (TST) are sedimentation devices that are used to capture traction sand or abrasives from stormwater runoff. These traps may take the form of basins, modified drainage inlets, or vaults.

The following sections give a brief overview of TST devices and a summary of design criteria. The PE shall refer to *Caltrans Traction Sand Traps Design Guidance* for schematics and complete guidance on design criteria, site evaluation, and preliminary and final design.

B.6.1 Description

There are four basic types of TSTs:

1. Modified Drainage Inlet;
2. Loading Docks;
3. Earthen Berm; and
4. Sand Vault.

The Modified Drainage Inlet TSTs can be modified standard drainage inlets (cast-in-place, precast, or pipe (steel or concrete)) with an outflow pipe offset from the invert of the trap to capture sand and sediment. Inlets can also function as a standard catch basin and multiple inlets can be placed in-line to increase sand storage. Sites that have small traction sand volumes and/or limited space are the most suitable for Modified Drainage Inlet traps. Weep holes are required to eliminate standing water.

The Loading Dock TST is designed as a sedimentation basin used to settle and store the anticipated traction sand volume. A Loading Dock TST is most appropriate when a large amount of recovered traction sand is estimated and right of way and visual impacts are not a concern.

The Earthen Berm type TST is similar to the Loading Dock type TST, but uses earthen berms to stabilize basin walls. The Earthen Berm type TST may be used in series with Infiltration Devices or other Treatment BMPs as a pre-treatment device. In this configuration, the Earthen Berm type TST acts as a sedimentation basin, and is separated from the Infiltration or other Treatment BMP by a partially buried Temporary Railing (Type-K) that acts as a sediment weir. The traction sand settles in the Earthen Berm type TST and the water flows over the sediment weir into the Infiltration Device or other Treatment BMP. This type of TST is most appropriate when a large amount of recovered traction sand is estimated, visual impacts are a concern, and right of way is not limited.

The Sand Vault TST consists of one or more underground structures placed in-line or side-by-side within storm drain systems to capture traction sand. The vault has a sedimentation chamber to slow flow velocities and settle sand. This type of TST is most appropriate when a large amount of recovered traction sand is estimated and limited right of way is a concern.

B.6.2 Appropriate Applications and Siting Constraints

TSTs should be used at sites where traction sand or abrasives are applied to the roadway at least twice a year. When it snows, abrasives are commonly applied to the roadway for traction. As the snow melts, or during subsequent storm events, the stormwater has the potential to transport sand to the storm drain system and ultimately to a receiving water body. This can result in sediment and other pollutants entering the storm water. TSTs are deployed to collect the sand and prevent sediment discharges while decreasing the potential for clogging. A typical TST is a sedimentation device that temporarily detains runoff and allows traction sand to settle out, while accommodating peak hydraulic flows.

B.6.3 Factors Affecting Preliminary Design

Siting and design criteria are summarized in Table B-5 below.

Table B 5. Summary of Traction Sand Trap Siting and Design Criteria		
Description	Applications/Siting	Preliminary Design Factors
<p>Sedimentation devices that temporarily detain runoff and allow traction sand to settle out. May be basins, modified drainage inlets, or vaults. Designed for peak hydraulic flow.</p> <p>Treatment Mechanisms:</p> <ul style="list-style-type: none"> • Sedimentation <p>Pollutants removed:</p> <ul style="list-style-type: none"> • Sand or other traction-enhancing substances 	<ul style="list-style-type: none"> • Sites where sand or other traction-enhancing substances are commonly applied to the roadway • Not considered where sand is used only rarely (less than twice a year) • Use Detention Basins or forebays as TST whenever feasible; if they are not feasible, then consider modified drainage inlets or vaults • Locate device so water is not introduced above the roadway subgrade in case of blockage 	<ul style="list-style-type: none"> • Design for anticipated sand recovery and cleanout interval • To the extent possible, stabilize areas within the tributary area to control sediment loads • Divert peak hydraulic flow if practical • Design to avoid or minimize scour • Provide, if possible, temporary storage volume (for sedimentation) using a minimum of 0.5 ft between top of sand (just prior to scheduled cleanout) and outlet pipe • Sufficient hydraulic head for gravity flow • Inlet and outlet arrangement to minimize short-circuiting of the flow • Weep holes to allow proper drainage • Invert minimum of 3ft above seasonally high groundwater if drainage is allowed through base (drainage inlet or vault type) • Maximum depth of inlet or vault of 10 ft below ground surface (varies with equipment – consult District Maintenance) • Maintenance space and/or access ramps for large equipment (a maintenance vehicle access shoulder of up to 16 ft may be required; consult with District Maintenance)

B.6.4 Checklist

Checklist T-1, Part 5 is provided to assist the PE in evaluating the feasibility of TSTs for a project, and the checklist identifies design elements that should be considered in the design of traction sand traps. The checklist is provided as a tool and does not need to be attached to SWDR or submitted as part of the PID, PA/ED, or PS&E process.

Treatment BMPs		
Checklist T-1, Part 5		
Prepared by: _____	Date: _____	District-Co-Route: _____
PM: _____	Project ID/EA: _____	RWQCB: _____

Traction Sand Traps

Feasibility

1. Can a Detention Device be sized to capture the estimated traction sand and the WQV, or portion thereof, from the tributary area? Yes No
 If Yes, then a separate Traction Sand Trap may not be necessary. Coordinate with the District/Regional Design Stormwater Coordinator and also complete Checklist T-1, Part 5.

2. Is the Traction Sand Trap proposed for a site where sand or other traction enhancing substances are applied to the roadway at least twice per year? Yes No

3. Is adequate space provided for maintenance staff and equipment access for annual cleanout? Yes No

- If the answer to any one of Questions 2 or 3 is No, then a Traction Sand Trap is not feasible. Yes No

4. Does adequate area exist within the RW to place Traction Sand Traps? Yes No
 If Yes, continue to Design Elements section. If No, continue to Question 5.

5. If adequate area does not exist within RW, can suitable, additional RW be acquired to site Traction Sand Traps and how much RW would be needed? _____ acres Yes No
 If Yes, continue to the Design Elements section. If No, continue to Question 6.

6. If adequate area cannot be obtained, document in Section 6 of the SWDR that the inability to obtain adequate area prevents the incorporation of this Treatment BMP into the project. Complete



Design Elements

* **Required** Design Element – A “Yes” response to these questions is required to further the consideration of this BMP into the project design. Document a “No” response in Section 5 of the SWDR to describe why this Treatment BMP cannot be included into the project design.

** **Recommended** Design Element – A “Yes” response is preferred for these questions, but not required for incorporation into a project design.

1. Was the local Caltrans Maintenance Station contacted to provide the amount of traction sand used annually at the location? *
List application rate reported. _____ yd³ Yes No

2. Does the Traction Sand Trap have enough volume to store settled sand over the winter (see Section 3.2 of *Caltrans TST Design Guidance*)? * Yes No

3. If the Traction Sand Trap has either an open bottom or weep holes, is the invert a minimum of 3 ft above seasonally high groundwater? * * Yes No

4. Is the maximum depth of the storage within 10 ft of the ground surface, or another depth as required by District Maintenance? * (Inlet or vault type) Yes No

5. Can peak flow be diverted around the device? * * (Inlet or vault type) Yes No

6. Is a 6-inch separation provided between the top of the captured traction sand and the outlet from the device, in order to minimize re-suspension of the solids? * * (Inlet or vault type) Yes No

B.7 Dry Weather Flow Diversion

Dry Weather Flow Diversion devices provide permanent treatment by directing non-stormwater flow through a pipe or channel to a municipal sanitary sewer system (publicly owned treatment works [POTWs]) during the dry season or dry weather. This flow must be generated by Caltrans activities or from Caltrans facilities. The following sections give a brief overview of dry weather flow diversion devices and a summary of design criteria.

B.7.1 Description

Typically, dry weather flow diversions are constructed across the dry weather flow drainage channel so the dry weather flows are diverted to a pipe or channel leading to the sanitary sewer. A gate, weir, or valve should be installed to stop the diversion during the wet season or during storms during the wet season (if the diversion will be made year-round). Accordingly, the conveyance to the sanitary sewer should be sized for the dry weather (non-storm) flows only. Wet weather flow is diverted (or remain undiverted, depending upon the design) back to the stormwater conveyance system.

If possible, a screen or trash rack should be installed at the diversion to reduce the likelihood of clogging the diversion pipe or channel. Maintenance vehicle access should be provided, especially if a screen is installed.

B.7.2 Appropriate Applications and Siting Criteria

Dry Weather Flow Diversions should only be considered when all of the following conditions apply:

- Dry weather flow is the result of Caltrans activities
- Dry weather flow is persistent (i.e., present over a significant length of time at a relatively consistent flow rate, or having significant quantities that are periodically developed on-site), and contains pollutants;
- An opportunity for connecting to a sanitary sewer is reasonably close and would not involve extraordinary plumbing, features or construction practices to implement (e.g., jacking under a freeway);
- The Publicly Owned Treatment Works (POTW) is willing to accept the flow during the dry season or dry weather.

An example of dry weather flow that could be considered for diversion is the runoff from a Caltrans tunnel generated during cleaning using water spray and scrubbing.

B.7.3 Factors Affecting Preliminary Design

Siting and design criteria are summarized in Table B-6 below.

Table B 6. Summary of Dry Weather Flow Diversion Siting and Design Criteria		
Description	Applications/Siting	Preliminary Design Factors
Direct flow during dry weather (or non-storm periods) to a POTW. Treatment flow rate determined on a site-specific basis (not the WQF). Treatment Mechanisms: <ul style="list-style-type: none"> • Wastewater treatment plant Pollutants removed: <ul style="list-style-type: none"> • All constituents 	Only when the conditions below apply: <ul style="list-style-type: none"> • Dry weather flow is persistent (consistent flow rate and significant length of time) • Connection would not involve extraordinary plumbing, features or construction practices to implement • POTW willing to accept dry weather flow 	<ul style="list-style-type: none"> • Berm or wall across channel to divert dry weather flow to the sanitary sewer • Gate, weir, or valve to stop diversion during wet season • Conveyance to sanitary sewer sized only for dry weather flow • Consider a screen or trash rack to limit debris conveyed to the POTW • Maintenance vehicle access

B.7.4 Checklist

Checklist T-1, Part 6 is provided to assist the PE in evaluating the feasibility of dry weather flow diversion devices for a project, and the checklist identifies design elements that should be considered in the design of dry weather flow diversion devices. The checklist is provided as a tool and does not need to be attached to SWDR or submitted as part of the PID, PA/ED, or PS&E process.

Treatment BMPs		
Checklist T-1, Part 6		
Prepared by: _____	Date: _____	District-Co-Route: _____
PM: _____	Project ID/EA: _____	RWQCB: _____

Dry Weather Flow Diversion

Feasibility

1. Is a Dry-Weather Flow Diversion acceptable to a Publicly Owned Treatment Works (POTW)? Yes No
2. Would a connection require ordinary (i.e., not extraordinary) plumbing, features or construction methods to implement? Yes No
 If "No" to either question above, Dry Weather Flow Diversion is not feasible.
3. Does adequate area exist within the RW to place Dry Weather Flow Diversion devices? Yes No
 If "Yes", continue to Design Elements sections. If "No", continue to Question 4.
4. If adequate area does not exist within RW, can suitable, additional RW be acquired to site Dry Weather Flow Diversion devices and how much RW would be needed? _____ (acres) Yes No
 If "Yes", continue to the Design Elements section.
 If "No", continue to Question 5.
5. If adequate area cannot be obtained, document in Section 6 of the SWDR that the inability to obtain adequate area prevents the incorporation of this Treatment BMP into the project. Complete

Design Elements

* **Required** Design Element – A "Yes" response to these questions is required to further the consideration of this BMP into the project design. Document a "No" response in Section 6 of the SWDR to describe why this Treatment BMP cannot be included into the project design.

** **Recommended** Design Element – A "Yes" response is preferred for these questions, but not required for incorporation into a project design.

1. Does the existing sanitary sewer pipeline have adequate capacity to accept project dry weather flows, or can an upgrade be implemented to handle the anticipated dry weather flows within the project's budget and objectives? * Yes No
2. Can the connection be designed to allow for maintenance vehicle access? * Yes No
3. Can gate, weir, or valve be designed to stop diversion during storm events? * Yes No
4. Can the inlet be designed to reduce chances of clogging the diversion pipe or channel? * Yes No
5. Can a back flow prevention device be designed to prevent sanitary sewage from entering storm drain? * Yes No

B.8 Gross Solids Removal Devices (GSRDs): Linear Radial and Inclined Screen

Gross Solids Removal Devices (GSRDs) include physical or mechanical methods to remove litter and solids 0.20 inch nominal¹ and larger from the stormwater runoff, usually done using various screening technologies. There are two approved GSRD types that were specifically designed for 100 percent gross solids removal from stormwater runoff, and with the capacity to retain one year's worth of solids loading to facilitate annual cleaning; the Linear Radial and the Inclined Screen.

The following sections give a brief overview of GSRDs and a summary of design criteria. The PE shall refer to *Caltrans Gross Solids Removal Devices Design Guidance* for complete guidance on design criteria, site evaluation, preliminary, and final design.

B.8.1 Description

The Linear Radial Device has two configurations. One type (referred to as "Linear Radial") is used for influent runoff velocities up to 8.2 feet per second; as shown in Figure B-4, the first 2.8 feet of the Linear Radial well casing is non-louvered with an open top to allow for influent bypass should the device become clogged with litter. The other type (referred to as "Linear Radial (HV)") is for influent velocities greater than 8.2 feet per second, and is shown in Figure B-5. The Linear Radial (HV) has an energy dissipation vault separate from the main vault, and overflows occur by overtopping the initial vault into the second chamber.

Rendered images of the Linear Radial types are presented in Figures B-4 and B-5. Figure B-6 shows a Linear Radial Device partially full of debris.

¹ The 0.20-inch dimension is based on requirements set forth in trash TMDLs applicable to certain watersheds.

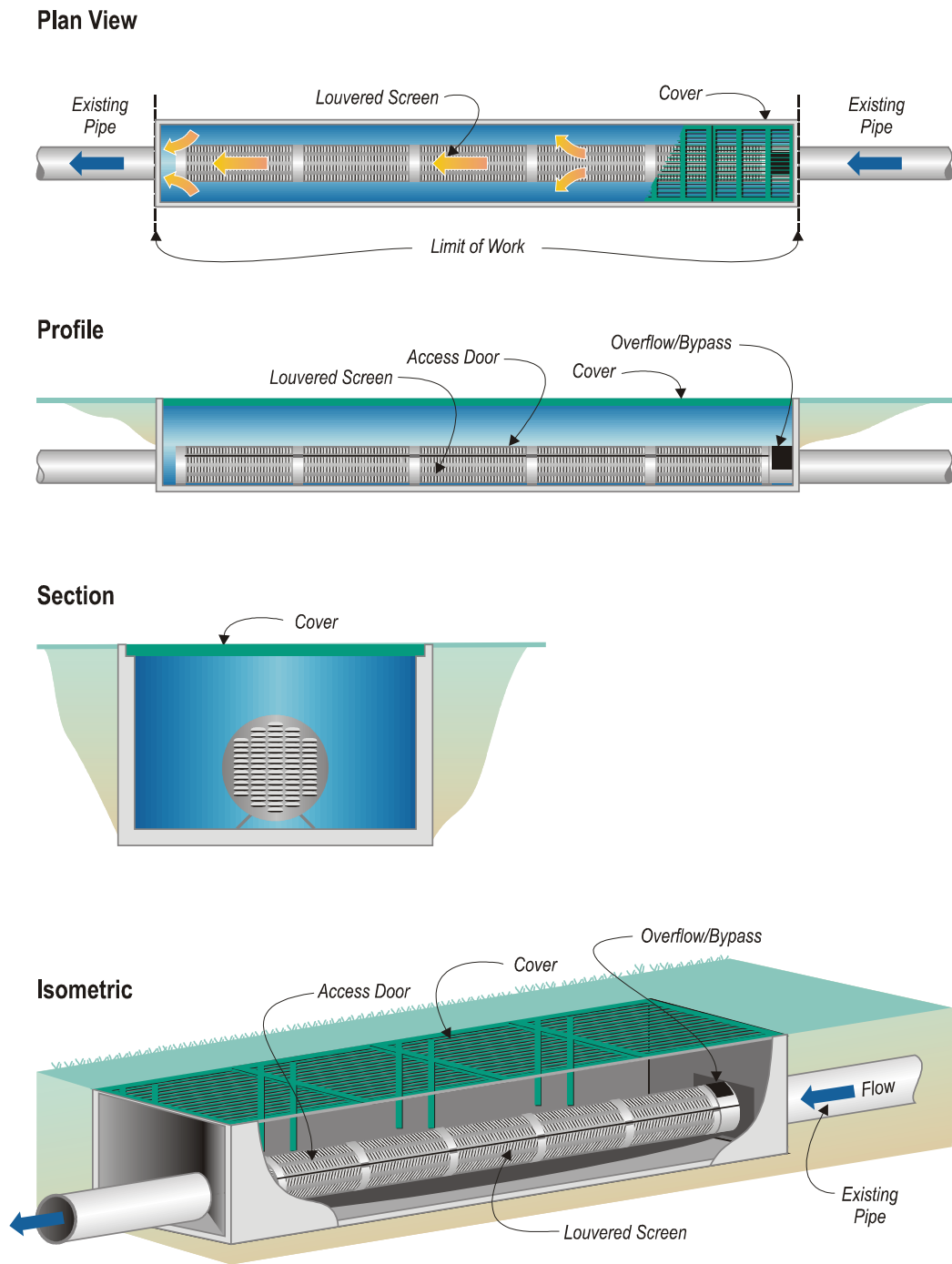

Figure B-4. Schematic of Linear Radial Device

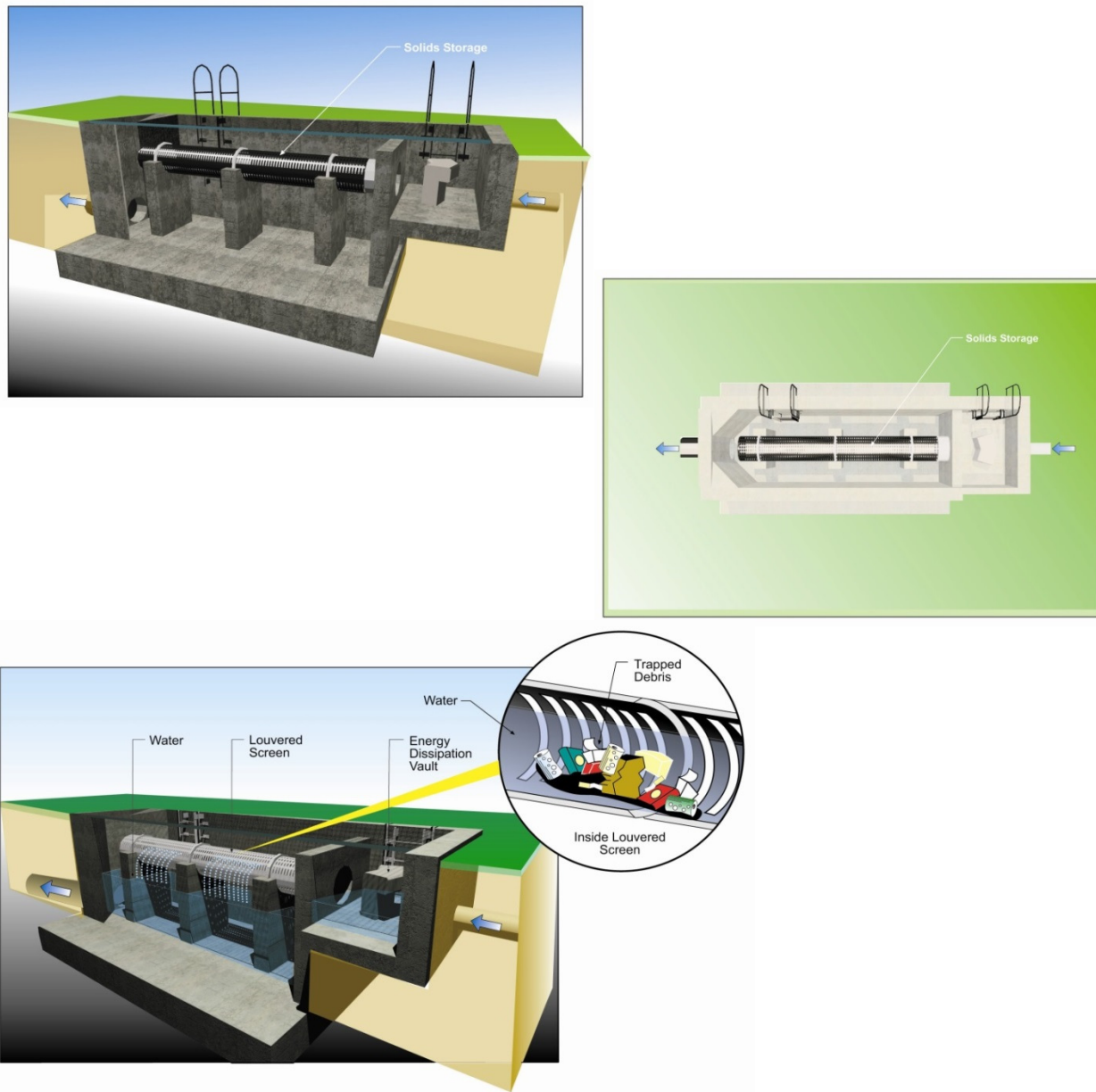

Figure B-5. Schematic of Linear Radial Device (HV)



Figure B-6. Linear Radial Device (partially full)

The Inclined Screen Device is designed for flows up to 20.39 cfs. This device uses a wedge-wire screen to remove litter, debris, and gross solids. With this GSRD the stormwater runoff enters at the top of the device and flows down the screen. The runoff passes through the screen while the litter, debris, and gross solids are pushed down the screen and retained in a confined storage area at the bottom of the device. This device uses flow deflectors and dispersion plate to increase the self-cleaning efficiency of the device which will decrease maintenance efforts. A curved section aids in flow separation between the dissipation slab and top of screen.

Rendered images of the Inclined Screen are presented in Figure B-7.

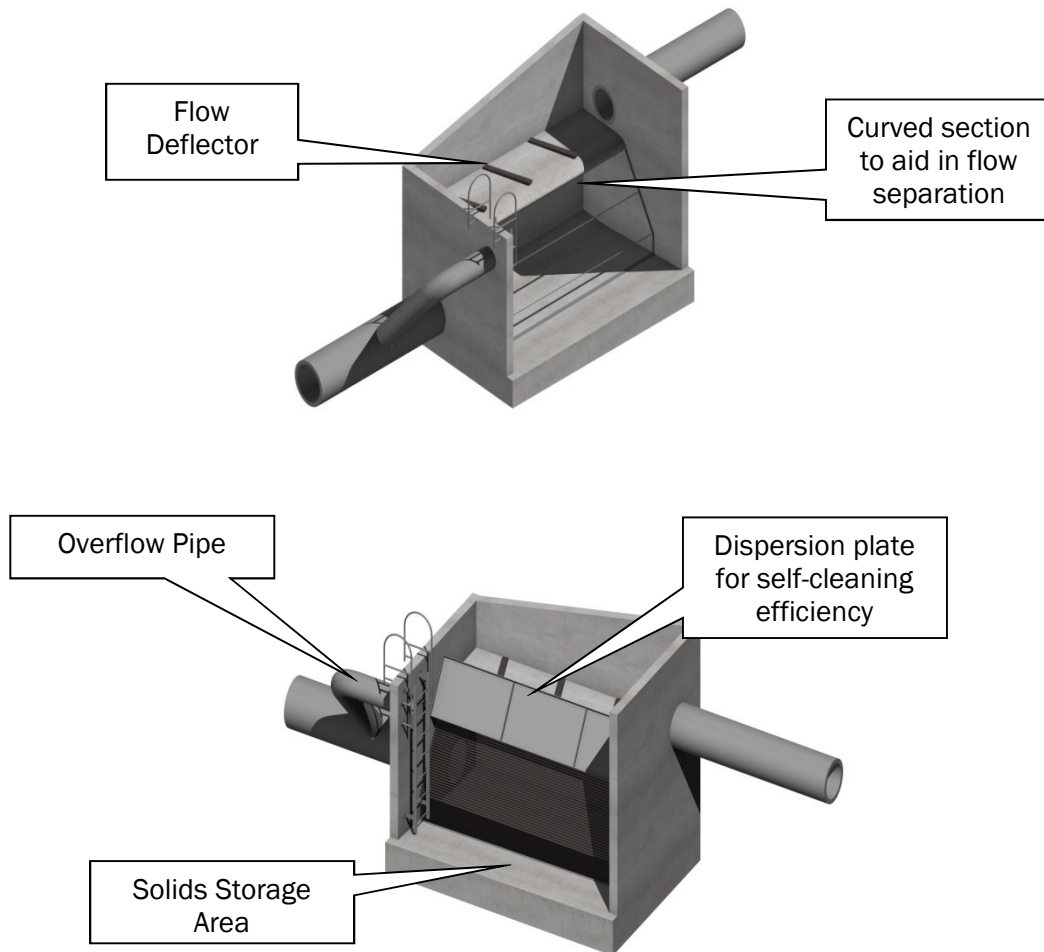

Figure B-7. Inclined Screen Device

B.8.2 Appropriate Applications and Siting Criteria

GSRDs should be considered for projects in watersheds where a TMDL allocation or 303(d) listing for litter has been made. The Linear Radial device requires very little head to operate and is well suited for narrow and relatively flat RW. The Inclined Screen device requires about 5.5 ft of head and is better suited for fill sections of highways. All GSRDs require sufficient space and/or access ramps for maintenance and inspection including the use of vacuum trucks or other large equipment to remove accumulated trash. Consider using fiberglass reinforced plastic frame and grate in high vandalism areas. Consult District/Regional Design Stormwater Coordinator and District Maintenance when considering these alternative materials.

B.8.3 Factors Affecting Preliminary Design

Siting and design criteria are summarized in Table B-7 below.

Table B 7. Summary of Gross Solids Removal Devices (Linear Radial and Inclined Screen)		
Description	Applications/Siting	Preliminary Design Factors
<p>Devices to capture and remove litter from the stormwater runoff.</p> <ul style="list-style-type: none"> Designed to handle up to the design storm event (reference HDM Chapter 830) unless placed in an offline configuration <p>Treatment Mechanisms:</p> <ul style="list-style-type: none"> Filtration through screens <p>Pollutants removed:</p> <ul style="list-style-type: none"> Litter and solid particles removed 0.20 inch nominal and larger 	<ul style="list-style-type: none"> Site conditions must have adequate space for device and maintenance activities Sites that drain to litter sensitive receiving waters on 303(d) list for trash or areas where TMDLs require trash removal The Linear Radial Device requires little head to operate and is well suited for flat sections of highway The Inclined Screen requires 66 inches of elevation drop between inlet and outlet pipe flow lines; it is well suited for fill sections Locate outside the Clear Recovery Zone (HDM Topic 309.1), or consult with Traffic Operations to determine if guard railing is required 	<ul style="list-style-type: none"> Design using regional litter accumulation data if available, otherwise use 10 ft³/acre/yr Devices must be sized for peak design flow (1-year, 1-hour storm event) while holding design (typically annual) gross solids load Overflow release device is based upon the design storm event (typically the 25-year, 24-hour event) The standard Linear Radial Device well casing is 24-inch diameter Standard designs for the Linear Radial GSRD have been evaluated for flows up to 22 cfs. If design flows exceed 22 cfs, then consider incorporating a flow-splitter device upstream of the GSRD to divert peak flows Structure and grate do not support traffic load. Traffic-rated GSRD would require special design Determine location and depth of device for maintenance access (coordinate with District Maintenance)

B.8.4 Checklist

Checklist T-1, Part 7 is provided to assist the PE in evaluating the feasibility of GSRDs for a project, and the checklist identifies design elements that should be considered in the design of GSRDs. The checklist is provided as a tool and does not need to be attached to SWDR or submitted as part of the PID, PA/ED, or PS&E process.

Treatment BMPs		
Checklist T-1, Part 7		
Prepared by: _____	Date: _____	District-Co-Route: _____
PM: _____	Project ID/EA: _____	RWQCB: _____

Gross Solids Removal Devices (GSRDs)

Feasibility

1. Is the receiving water body downstream of the tributary area to the proposed GSRD on a 303(d) list or has a TMDL for litter been established? Yes No

2. Are the devices sized for flows generated by the peak drainage facility design event (1-year, 1-hour) or can peak flow be diverted? Yes No

3. Are the devices sized to contain gross solids (litter and vegetation) for a period of one year? Yes No

4. Is there sufficient access for maintenance and large equipment (vacuum truck)? Yes No

If “No” to any question above, then Gross Solids Removal Devices are not feasible. Note that Biofiltration Systems, Infiltration Devices, Detention Devices, Dry Weather Flow Diversion, and Media Filters may be considered for litter capture, but consult with District/Regional NPDES Coordinator if proposed to meet a TMDL for litter.

5. Does adequate area exist within the RW to place Gross Solids Removal Devices? Yes No

If “Yes”, continue to Design Elements section. If “No”, continue to Question 6.

6. If adequate area does not exist within RW, can suitable, additional RW be acquired to site Gross Solids Removal Devices and how much RW would be needed? _____ acres Yes No

If “Yes”, continue to Design Elements section. If “No”, continue to Question 7.

7. If adequate area cannot be obtained, document in Section 6 of the SWDR that the inability to obtain adequate area prevents the incorporation of this Treatment BMP into the project. Complete

Design Elements – Linear Radial Device

* **Required** Design Element – A “Yes” response to these questions is required to further the consideration of this BMP into the project design. Document a “No” response in Section 6 of the SWDR to describe why this Treatment BMP cannot be included into the project design.

** **Recommended** Design Element – A “Yes” response is preferred for these questions, but not required for incorporation into a project design.

- 1. Does sufficient hydraulic head exist to place the Linear Radial GSRD? * Yes No
- 2. Is a fiberglass reinforced plastic frame and grate being considered for high vandalism areas? Consult District Maintenance. ** Yes No
- 3. Was the litter accumulation rate of 10 ft³/ac/yr (or a different rate recommended by District Maintenance) used to size the device? * Yes No
- 4. Was the overflow release device sized for the design storm event? * Yes No
- 5. Were the standard detail sheets used for the layout of the devices? ** Yes No
If No, consult with OHSD and District/Regional Design Stormwater Coordinator.
- 6. Is the maximum depth of the storage within 10 ft of the ground surface, or another depth as required by District Maintenance? * Yes No

Design Elements – Inclined Screen

* **Required** Design Element – A “Yes” response to these questions is required to further the consideration of this BMP into the project design. Document a “No” response in Section 6 of the SWDR to describe why this Treatment BMP cannot be included into the project design.

** **Recommended** Design Element – A “Yes” response is preferred for these questions, but not required for incorporation into a project design.

- 1. Does sufficient hydraulic head exist to place the Inclined Screen GSRD? * Yes No
- 2. Was the litter accumulation rate of 10 ft³/ac/yr (or a different rate recommended by District Maintenance) used to size the device? * Yes No
- 3. Is a fiberglass reinforced plastic frame and grate being considered for high vandalism areas? Consult District Maintenance. ** Yes No
- 4. Was the overflow release device sized for the design storm event? * Yes No
- 5. Were the standard details sheets used for the layout of the devices? ** Yes No
If No, consult with OHSD and District/Regional Design Stormwater Coordinator.
- 6. Is the maximum depth of the storage within 10 ft of the ground surface, or another depth as required by District Maintenance? * Yes No



B.9 Media Filters

A Media Filter Treatment BMP device primarily removes TSS pollutants (sediments and metals) from runoff by sedimentation and filtering, and also is effective for dissolved metals, litter and potentially some nutrients (depending upon type of Media Filter selected).

The following sections give a brief overview of media filters and a summary of design criteria. The PE shall refer to *Caltrans Austin Sand Filter – Earthen Type Design Guidance*, *Caltrans Partial Sedimentation Austin Vault Sand Filters Design Guidance*, and *Caltrans Delaware Sand Filters Design Guidance* for complete guidance on design criteria, site evaluation, and preliminary and final design.

B.9.1 Description

There are two types of approved Media Filter devices: The Austin Sand Filter and the Delaware Sand Filter; each is configured using two chambers. An Austin Sand Filter is usually open and at grade and has no permanent water pool; a Delaware Sand Filter is always configured with closed chambers and below grade and has a permanent pool of water. An Austin Sand Filter may be configured with earthen or concrete sides and invert; a Delaware Sand Filter is always made using concrete sides and invert.

In both types of Media Filters, stormwater is directed into the first chamber where the larger sediments and particulates settle out, and the partially treated effluent is metered into the second chamber to be filtered through a media. In the Austin Sand Filter, the first chamber may be sized for the entire WQV ('full sedimentation') (see Figure B-9) or as a 'partial sedimentation' chamber, holding only about 20 percent of the WQV (see Figure B-10); the Delaware Sand Filter holds the entire WQV in the initial chamber, and is designed to pass the WQV from the second chamber (see Figure B-11).

The treated effluent (filtered water) is captured by perforated underdrains (collector pipes) for release downstream. There is a drop in elevation of 3 ft to 6 ft between the invert of the inlet pipe and the invert of the device outflow pipe depending on device type, size and configuration. A lower drop in elevation may be considered; modifications to the standard may be required.

The filter media typically consists of clean sand, which is effective for removal of coarse and fine sediments and particulate metals. Other materials¹, such as topsoil or inorganic/organic materials may be added to the sand to increase the treatment capacity for some pollutants (for example, dissolved metals) but these additives often increase the nitrogen and phosphorus concentration levels in the effluent. Any variation to the media used in the design of a Media Filter must be coordinated through the HQ Division of Environmental Analysis – Policy, Planning and Permitting, and OHSD. When media filters are used to encourage infiltration or subsurface storage and mimic natural hydrology within small applications, then the media filters may be considered a LID

¹ The use of alternative media such as activated alumina was tentatively approved in June 2017. Alternative media may be used if requested by the PE and District/Regional NPDES Coordinator.

technique. For this application, the Austin Vault Sand Filter – Partial Sedimentation (Earthen Type) is used.



Figure B-8. Caltrans Pilot Media Filters (Austin Sand Filter [left], Delaware Sand Filter [right])

B.9.2 Appropriate Applications and Siting Criteria

Media Filters will perform better if the tributary area has a relatively high percentage of impervious area, and low sediment loading.

Sites proposed for Media Filters must have sufficient hydraulic head to operate by gravity; generally, between 3 to 6 ft of elevation drop is needed between the inflow to the initial chamber and effluent outflow from the second chamber.

Standard details for a vector-proof Delaware Sand Filter have been developed when vector control is an issue.

For earthen-type Media Filters, at least 5 ft separation from seasonally high groundwater should be provided. For vault-type Media Filters, the level of the concrete base of the vault must be above seasonally high groundwater unless by special design.

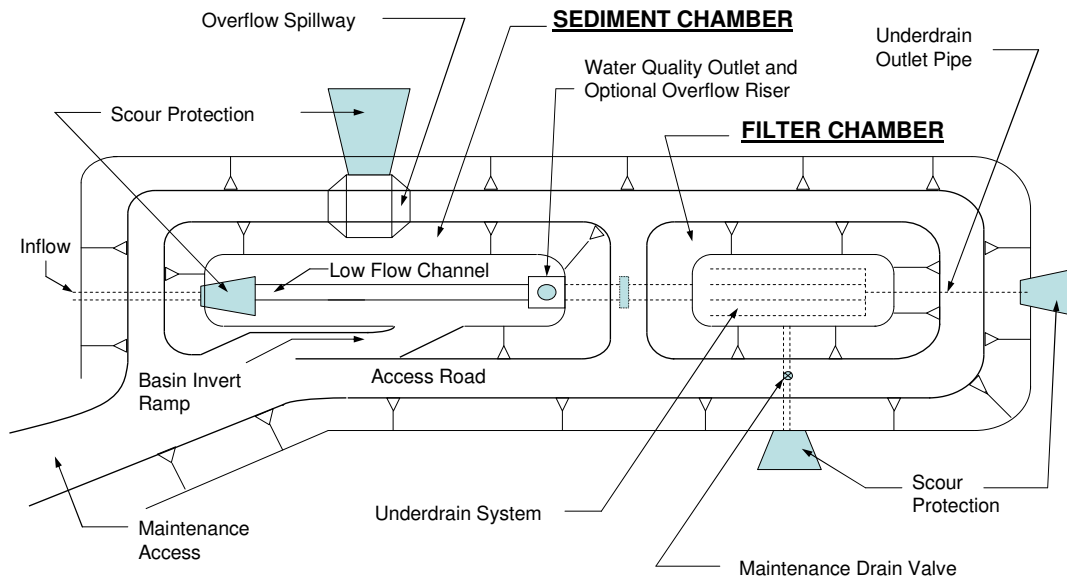

Plan View

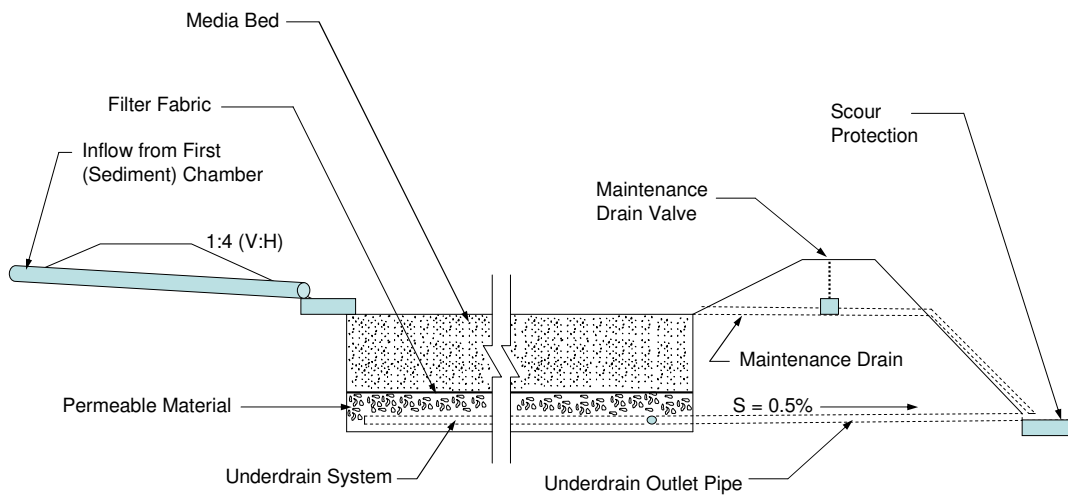

Second (Filter) Chamber Cross Section

NOT TO SCALE

Figure B-9. Schematic of an Austin Sand Filter - Full Sedimentation (Earthen Type)

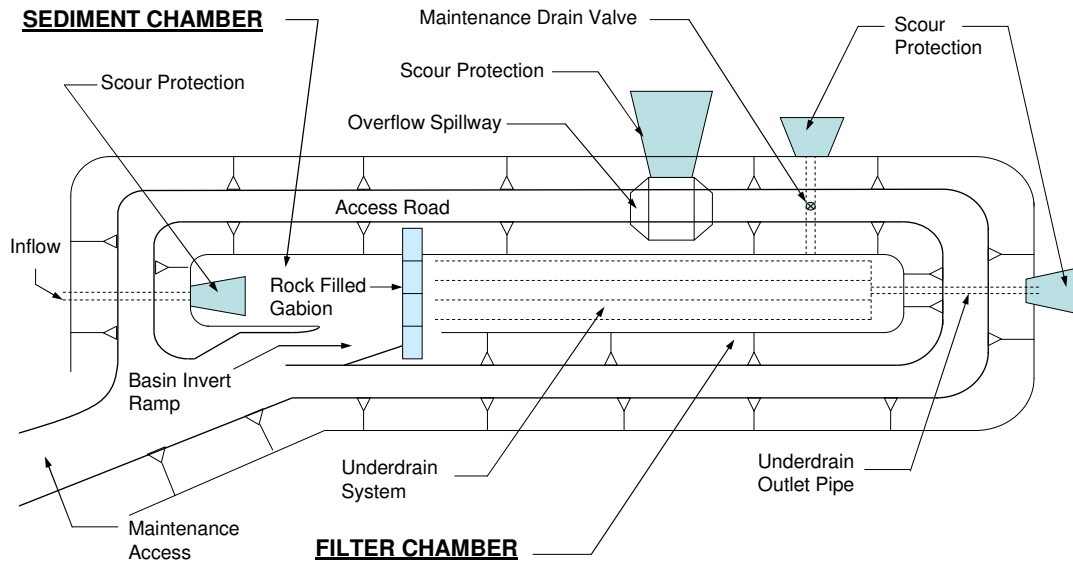

Plan View

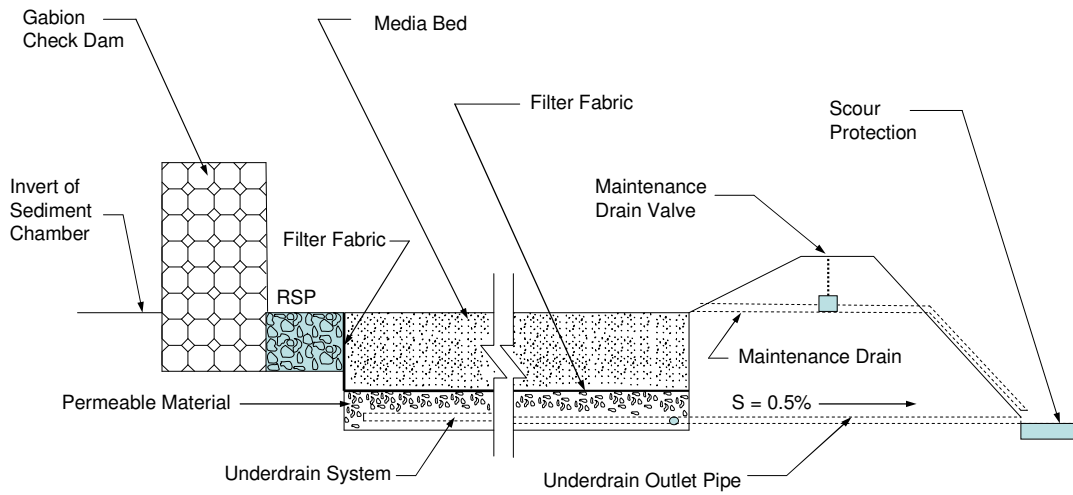

Second (Filter) Chamber Cross Section

NOT TO SCALE

Figure B-10. Schematic of an Austin Sand Filter - Partial Sedimentation (Earthen Type)

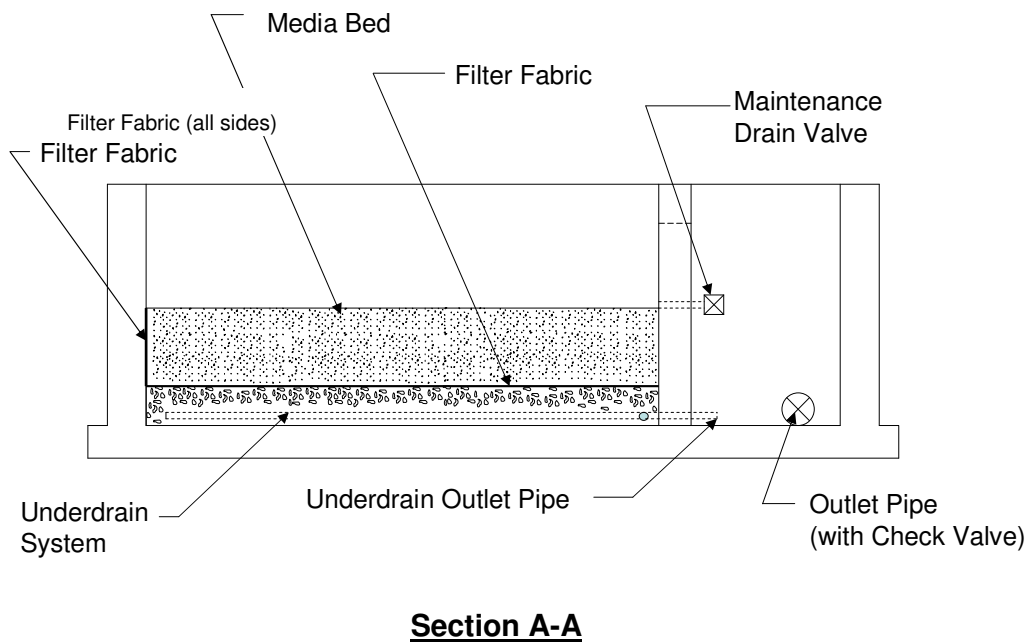
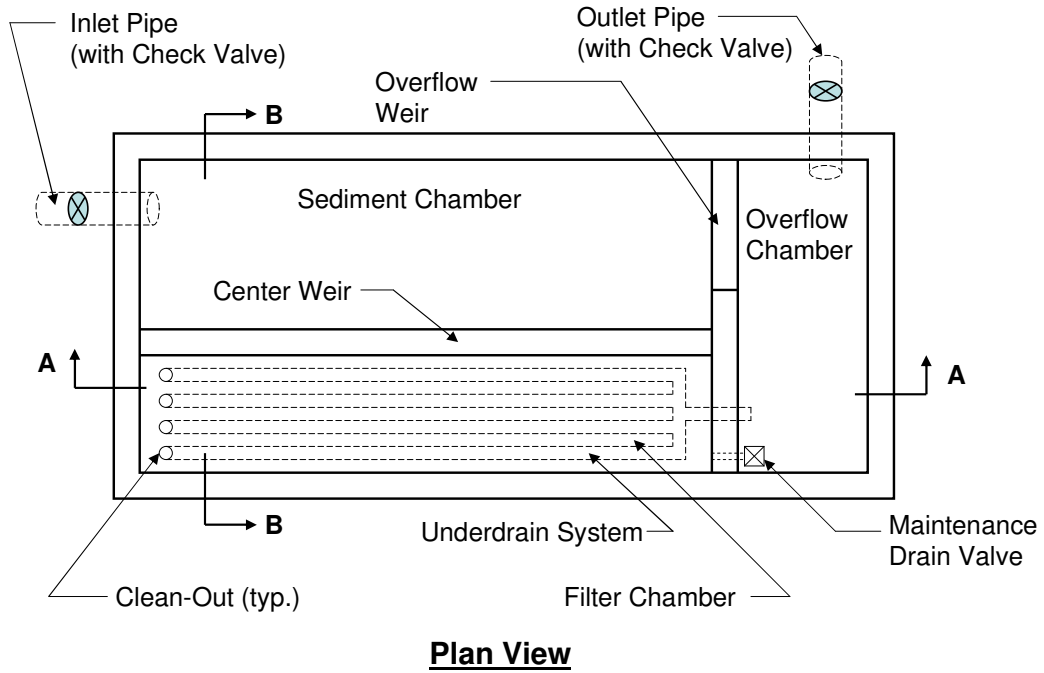

Figure B-11. Schematic of a Delaware Sand Filter

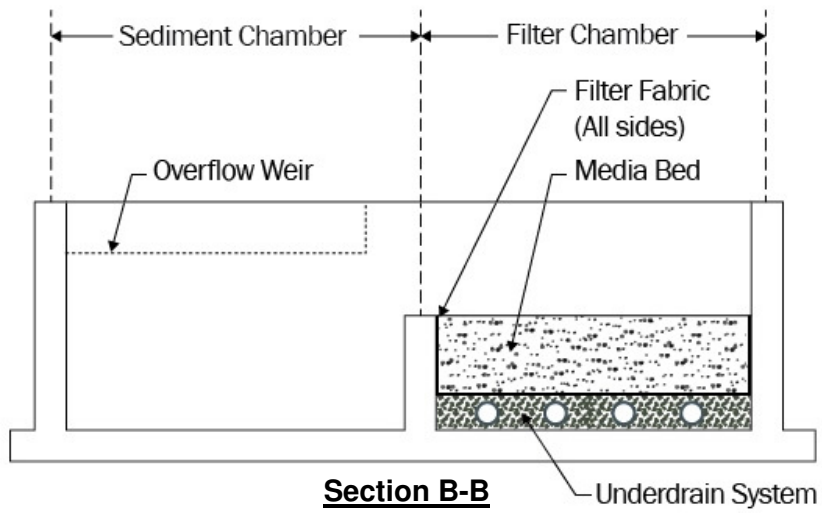

Figure B-11. Schematic of a Delaware Sand Filter (Continued).

B.9.3 Factors Affecting Preliminary Design

Siting and design criteria are summarized in Table B-8 below.

Table B 8. Summary of Media Device Siting and Design Criteria		
(Applicable to both Austin Sand Filter and Delaware Filter unless noted)		
Description	Applications/Siting	Preliminary Design Factors
<p>Two-chambered treatment devices designed to treat the WQV.</p> <p>Treatment Mechanisms</p> <ul style="list-style-type: none"> • Sedimentation • Filtration <p>Pollutants removed</p> <ul style="list-style-type: none"> • Suspended solids • Particulate metals • Dissolved metals • Litter (although preferred capture is upstream of the device) • Nutrients (depending on type of Media Filter selected) 	<ul style="list-style-type: none"> • Site must have sufficient hydraulic head to operate by gravity between inflow to the initial chamber and effluent outflow from the second chamber, about 3.0 to 6.0 ft • Delaware Media Filters should avoid locations where there are concerns about vectors because they maintain a permanent pool of water unless concurrence for its use can be obtained from the local vector control agency or use check valves and vector proof lid as shown on standard detail sheets • For earthen-type Media Filters, at least 5 ft separation from seasonally high groundwater should be provided, or less as justified by adequate groundwater information or RWQCB concurrence. For vault-type Media Filters, the level of the concrete base of the vault must be above seasonally high groundwater unless by special design • Will perform better if the tributary area has a relatively high percentage of impervious area, and low sediment loading • Maintenance must have access to both chambers • Locate outside the Clear Recovery Zone (HDM Topic 309.1), or design to be traversable, or consult with Traffic Operations to determine if guard railing is required 	<ul style="list-style-type: none"> • Maximum depth: 13 feet below ground surface; verify with District Maintenance • Upstream bypass for larger storms is preferred otherwise bypass storms > WQV through the device, typically using weirs from the initial chamber • Provide if possible, pretreatment to capture sediment in the runoff (such as with vegetation, flow splitter with sump, forebay, etc.) • Collector & lateral pipes: minimum 6-inch diameter • Filter materials: refer to specifications listed on the OHSD Treatment BMPs design guidance website • Austin, full sedimentation design: design the initial chamber to hold the entire WQV and use a 24-hour release time if site constraints allow, release to the second chamber using a perforated riser, and a length to width ratio of 2:1 should be provided for the sedimentation chamber* • For partial sedimentation designs, the initial chamber should be sized to hold ≥ 20 percent WQV. The filtration chamber should hold the remaining volume, which includes volume of the filtration chamber above the media to the flow line of the outfall pipe plus 35 percent of the total volume of the filtration chamber media (available storage volume of filtration chamber media is based upon 35 percent porosity of filter rock); provide a rock-filled gabion wall separating the chambers* • Design drain time for Austin Sand Filter is 24 hours. While the Delaware Sand Filter is between 40 to 48-hrs* • Austin Sand Filter: no permanent vegetation is desired in the second chamber* • Austin Sand Filter with earthen base and sides, full or partial: side slopes should be 3:1 (h:v) or flatter, and should be stabilized by vegetation. Consult the District Landscape Architect for types of vegetation that can function effectively

* Variations to certain Design Criteria are being considered and will be included in the Design Guidance for each type of media filter.

B.9.4 Checklist

Checklist T-1, Part 8 is provided to assist the PE in evaluating the feasibility of media filters for a project, and the checklist identifies design elements that should be considered in the design of media filters. The checklist is provided as a tool and does not need to be attached to SWDR or submitted as part of the PID, PA/ED, or PS&E process.

<p>Treatment BMPs</p> <p>Checklist T-1, Part 8</p>		
Prepared by: _____	Date: _____	District-Co-Route: _____
PM: _____	Project ID/EA: _____	RWQCB: _____

Media Filters

Caltrans has approved two types of Media Filters: Austin Sand Filter and Delaware Filter. An Austin Sand filter is typically designed for a larger contributing drainage area, while a Delaware Filter is typically designed for a smaller contributing drainage area. The Austin Sand Filter is constructed with an open top and may have a concrete or earthen invert, while the Delaware is always constructed as a vault.

Feasibility – Austin Sand Filter

1. Is the volume of the Austin Sand Filter equal to the WQV, or portion thereof, using a 24-hour drawdown? ¹ Yes No

2. Is there sufficient hydraulic head to operate the device (minimum 2 ft between the inflow and outflow chambers)? Yes No

3. If device has an earthen bottom, is the invert ≥ 5 ft above seasonally high groundwater? Yes No

4. If a vault is used for either chamber, is the level of the concrete base of the vault above seasonally high groundwater or is a special design provided?
If No to any question above, then an Austin Sand Filter is not feasible. Yes No

5. Does adequate area exist within the RW to place an Austin Sand Filter?
If Yes, continue to Design Elements sections. If No, continue to Question 6. Yes No

6. If adequate area does not exist within RW, can suitable, additional RW be acquired to site the device and how much RW would be needed to treat WQV, or portion thereof? _____ acres Yes No
If Yes, continue to the Design Elements section.
If No, continue to Question 7.

7. If adequate area cannot be obtained, document in Section 6 of the SWDR that the inability to obtain adequate area prevents the incorporation of this Treatment BMP into the project. Complete

If an Austin Sand Filter meets these feasibility requirements, continue to the Design Elements – Austin Sand Filter below.

¹Longer drawdown times being considered. Refer to the Austin Media Filter Design Guidance.

Feasibility- Delaware Filter

- 1. Is the volume of the Delaware Filter equal to the WQV, or portion thereof, using a 40 to 48-hour drawdown? ¹ Yes No

- 2. Is there sufficient hydraulic head to operate the device (minimum 2 ft between the inflow and outflow chambers)? Yes No

- 3. Would a permanent pool of water be allowed by the local vector control agency? Confirm that check valves and vector proof lid as shown on standard detail sheets will be allowed, and used. Yes No

- 4. Does the project discharge to a water body that has been placed on the 303(d) or has had a TMDL adopted for bacteria, mercury, sulfides, or low dissolved oxygen? Yes No
 If Yes, contact the District/Regional NPDES Coordinator to determine if standing water in this Treatment BMP would be a risk to downstream water quality. If standing water is a potential issue, consider use of another Treatment BMP.

 If No to any question, then a Delaware Filter is not feasible

- 5. Does adequate area exist within the RW to place a Delaware Filter? Yes No
 If Yes, continue to Design Elements section. If No, continue to Question 6.

- 6. If adequate area does not exist within RW, can suitable, additional RW be acquired to site the device and how much RW would be needed to treat WQV, or portion thereof? _____ acres Yes No
 If Yes, continue to the Design Elements section. If No, continue to Question 7.

- 7. If adequate area cannot be obtained, document in Section 6 of the SWDR that the inability to obtain adequate area prevents the incorporation of this Treatment BMP into the project. Complete

¹Longer drawdown times being considered. Refer to the Delaware Media Filter Design Guidance.

Design Elements – Austin Sand Filter

* **Required** Design Element – A “Yes” response to these questions is required to further the consideration of this BMP into the project design. Document a “No” response in Section 6 of the SWDR to describe why this Treatment BMP cannot be included into the project design.

** **Recommended** Design Element – A “Yes” response is preferred for these questions, but not required for incorporation into a project design.

- | | | | |
|-----|--|------------------------------|-----------------------------|
| 1. | Is the drawdown time of the device 24 hours? (Longer drawdown times being considered, refer to the <i>Austin Media Filter Design Guidance</i>)* | <input type="checkbox"/> Yes | <input type="checkbox"/> No |
| 2. | Is access for maintenance vehicles provided to the Austin Sand Filter? * | <input type="checkbox"/> Yes | <input type="checkbox"/> No |
| 3. | Is a bypass/overflow provided for storms > WQV? * | <input type="checkbox"/> Yes | <input type="checkbox"/> No |
| 4. | Is the flow path length to width ratio for the sedimentation chamber of the “full” Austin Sand Filter $\geq 2:1$? ** | <input type="checkbox"/> Yes | <input type="checkbox"/> No |
| 5. | Can pretreatment be provided to capture sediment and litter in the runoff (such as using vegetation)? ** | <input type="checkbox"/> Yes | <input type="checkbox"/> No |
| 6. | Can the Austin Sand Filter be placed using an earthen configuration? **
If No, go to Question 10. | <input type="checkbox"/> Yes | <input type="checkbox"/> No |
| 7. | Is the Austin Sand Filter invert separated from the seasonally high groundwater table by ≥ 5 ft)? * (If AVSF, see Table B-8 3 rd bullet in Application/Siting column.)
If No, design with an impermeable liner. | <input type="checkbox"/> Yes | <input type="checkbox"/> No |
| 8. | Are side slopes of the earthen chamber 3:1 (h:v) or flatter? * | <input type="checkbox"/> Yes | <input type="checkbox"/> No |
| 9. | Can vegetation be established at the invert and on the side slopes for erosion control and to minimize re-suspension? If No, include rock or similar protective system.
Note: Austin Sand Filters may be lined, in which case no vegetation would be required for lined areas.* | <input type="checkbox"/> Yes | <input type="checkbox"/> No |
| 10. | Is maximum depth of sedimentation chamber ≤ 13 ft below ground surface? * If greater than 13 feet, a special design is required. | <input type="checkbox"/> Yes | <input type="checkbox"/> No |
| 11. | Can the Austin Sand Filter be placed in an offline configuration? **
If No, go to Question 12. | <input type="checkbox"/> Yes | <input type="checkbox"/> No |
| 12. | Is the flow line elevation of the over flow pipe set at the same elevation as the top of gabion wall elevation? ** | <input type="checkbox"/> Yes | <input type="checkbox"/> No |

Typically, the flow line should match the top of gabion wall elevation. However, the pipe may require adjustment to fit site condition requirements such as grading and pipe cover conflicts and utility conflicts. Additional overflow designs may be considered (see the *Partial Sedimentation Austin Vault Sand Filter Design Guidance*).

Design Elements – Delaware Filter

* **Required** Design Element – A “Yes” response to these questions is required to further the consideration of this BMP into the project design. Document a “No” response in Section 6 of the SWDR to describe why this Treatment BMP cannot be included into the project design.

** **Recommended** Design Element – A “Yes” response is preferred for these questions, but not required for incorporation into a project design.

- | | | |
|--|------------------------------|-----------------------------|
| 1. Is the drawdown time of the device between 40 and 48 hours, typically 40-hrs?
(Longer drawdown times being considered, refer to the <i>Delaware Media Filter Design Guidance</i>) * | <input type="checkbox"/> Yes | <input type="checkbox"/> No |
| 2. Is access for maintenance vehicles provided to the Delaware Filter? * | <input type="checkbox"/> Yes | <input type="checkbox"/> No |
| 3. Is a bypass/overflow provided for storms > WQV? * | <input type="checkbox"/> Yes | <input type="checkbox"/> No |
| 4. Can pretreatment be provided to capture sediment and litter in the runoff (such as using vegetation)? ** | <input type="checkbox"/> Yes | <input type="checkbox"/> No |
| 5. Is maximum depth of sedimentation chamber ≤ 13 ft below ground surface? * | <input type="checkbox"/> Yes | <input type="checkbox"/> No |

B.10 Multi-Chamber Treatment Train (MCTT)

This device is rarely used and is not recommended, except in unique circumstances, such as non-highway facilities (parking lots, maintenance stations, etc.). Design information will continue to be supported on the OHSD website. Refer to B.1.6 Caltrans Treatment BMP Website for information available. Use Checklist T-1, Part 9 in the *Caltrans MCTT Design Guidance* when considering an MCTT. If device is being considered, incorporate into the SWDR.

A MCTT device primarily removes TSS pollutants (sediments and metals) from runoff by sedimentation and filtering and may also be effective for some dissolved metals and litter. The MCTT was developed for treatment of stormwater at critical source areas such as vehicle service facilities, parking areas, paved storage areas, and fueling stations.

B.11 Wet Basin

This device is rarely used and is not recommended, except in unique circumstances. Design information will continue to be supported on the OHSD website. Refer to B.1.6 Caltrans Treatment BMP Website for information available. Use Checklist T-1, Part 10 in the *Caltrans Wet Basin Design Guidance* when considering a Wet Basin. If device is being considered, incorporate into the SWDR.

Wet Basins are detention systems comprised of a permanent pool of water, a temporary storage volume above the permanent pool, and a shoreline zone planted with aquatic vegetation. Wet Basins are designed to remove pollutants from surface discharges by temporarily capturing and detaining the WQV, or portion thereof, in order to allow settling and biological uptake to occur. Wet Basins are recommended for the following pollutants: TSS; nutrients; particulate metals; pathogens; litter; and temperature.

B.12 Pervious Pavement

While pervious pavement has become very popular in the area of stormwater management, the true applicability to the highway environment is still unclear. The treatment function is infiltration. Pervious pavement is better suited for non-highway applications such as: landscaped areas, sidewalks, bike paths, miscellaneous pavement to accept run-on from adjacent impervious areas (e.g., roofs), parking lots, park-and-ride areas, maintenance access roads, rest areas, and maintenance stations. The only highway application accepted at this time is for a maintenance vehicle pullout. With pervious pavement, runoff infiltrates through the pavement and underlying soil in a manner similar to the infiltration devices described in Section B.3. Until more information is determined related to safety, maintainability, constructability, and improved water quality benefit over other approved BMPs, the inclusion of pervious pavement into Caltrans projects needs to be coordinated with the District/Regional Design Stormwater Coordinator.

Projects may consider pervious concrete pavement, pervious asphalt pavement, and permeable interlocking concrete pavement. There are limited locations where pervious pavement may be used. Refer to *Caltrans Pervious Pavement Design Guidance*:
<http://www.dot.ca.gov/hq/oppd/stormwtr/bmps.htm>



B.13 Open Graded Friction Course

Open Graded Friction Course (OGFC) has been used as an effective paving material for the reduction of noise and to reduce the spray from rainfall on the highway surface for better visibility during rain events. Further studies from other transportation agencies has shown significant reduction in pollutants from open graded highways than from traditional highways (ASCE 2012). The pollutant load reduction from open graded lanes in comparison to traditional highway runoff characterization for pollutants, would suggest that they are as effective at pollutant removal as many of the Caltrans approved Treatment BMPs. Caltrans already uses open graded AC for noise and spray reduction, so using for the dual purpose of water quality improvement is a sustainable way to provide pollutant removal and treatment of storm water runoff.

B.13.1 Description

An OGFC is a sacrificial wearing course consisting of an aggregate with relatively uniform grading and little or no fine aggregate and mineral filler. It is designed to have a large number of void spaces in the compacted mix.

OGFC would be considered a flow-through treatment device as it would not infiltrate stormwater, though some stormwater would be captured in the OGFC voids. For this reason, designers should first use the Caltrans PPDG T-1, Part 1 checklist for the selection of appropriate BMPs. OGFC can provide treatment from the highway runoff and meet the NPDES permit requirements for maximum extent practicable.

Where roadway project conditions would benefit from the use on OGFC as described in “Open Graded Friction Course Usage Guide”, February 8, 2006, credit for stormwater treatment should be calculated and claimed.

The Open Graded Friction Course Usage Guide is available at:
<http://www.dot.ca.gov/hq/esc/Translab/ormt/pdf/FrictionCourseGuide.pdf>

For additional details on design, see the *Caltrans Open Graded Friction Course Treatment BMP Design Guidance* on the OHSD website.

B.13.2 Appropriate Applications and Siting Criteria

Appropriate locations for OGFC are as described in the Caltrans Open Graded Friction Course Usage Guide, February 2006 and where:

- Lower elevation highways where traction sand is not applied and freezing temperatures are rare;
- Highway sections that do not receive runoff from cut sections;
- Highway section that do not receive offsite sediment laden stormwater flows; and
- Drainage areas that are entirely made up of impervious surfaces.

OGFC should not be used as a Treatment BMP if there is a conflict with the Caltrans Open Graded Friction Course Usage Guide.



OGFC pollutant removal treatment mechanism is filtration through the void space of the OGFC layer and reduction of water splashing on the vehicle undercarriage. A portion of the calculated treatment can be attributed to the reduction of water splashed up from the pavement and to the under body of vehicles. The treatment area generated by the BMP is the total area of the OGFC.

Porous pavement overlays are an existing Caltrans practice. No additional maintenance requirements beyond what is described in the Caltrans Open Graded Friction Course Usage Guide are anticipated.

B.14 Bioretention

Detailed design guidance for bioretention is currently under development. Until this effort is completed, the provisional guidance contained in this section will provide general direction for Bioretention Treatment BMP design. In addition to design guidance, construction details and specifications for Bioretention Treatment BMPs are under development. Non-standard special provisions (nSSPs) should be submitted in the interim for Treatment BMP design to the Office of Hydraulics and Stormwater Design (OHSD).

Bioretention is a low impact development (LID), vegetation and soil-based practice utilizing chemical and biological properties of soil to reduce pollutants, as well as its physical characteristics to attenuate stormwater flows. The main treatment mechanisms of bioretention include filtration, absorption, microbiological actions, chemical reactions, and typically infiltration into the underlying soil. Configurations and components that comprise a bioretention treatment device can vary, including basin shapes and sizes, types of vegetation, soil and subsurface layer composition, and outlet drains. Caltrans supports innovative design alternatives with consideration of the *Highway Design Manual* (HDM) standards.

B.14.1 Description

Bioretention Treatment BMPs are part of the highway drainage system and can be designed to attenuate peak flows and infiltrate the water quality volume. The amount of volume reduction and flow attenuation varies with drainage design. Bioretention Treatment BMPs commonly have the following three components:

- 1) A temporary volume of pooled or flowing stormwater runoff.
- 2) A layer of biologically active soil and vegetation appropriate for the location, usually grasses and perennials.
- 3) A sub-surface retention layer to temporarily detain stormwater runoff within gravel or other high void space material.

Bioretention TBMPs are categorized as two types:

- 1) The infiltration type is designed to remove pollutants from surface discharges by capturing and retaining the WQV, or a portion thereof, and infiltrating it directly into the soil.
- 2) The flow-through type is designed to remove pollutants by filtering the WQF through the soil and retention layers before discharging to surface waters. This type includes a perforated drain to collect the treated effluent from the subsurface layer.

Variations in designs appropriate for specific site conditions may be required.

B.14.2 Appropriate Applications, Siting, and Design Criteria

Bioretention Treatment BMPs should be considered for implementation in areas that receive flow from impervious surfaces. Bioretention meets the NPDES permit prioritization for treatment using soil based LID BMPs and infiltration of the WQV event when siting conditions allow. Other variations of Bioretention Treatment BMPs can be used, but may be less effective when infiltration does not occur. Liners should be used when siting BMPs where infiltration may cause stability issues or where infiltration may cause negative groundwater effects.

Bioretention Treatment BMPs should be sized to meet the Caltrans NPDES permit requirements in Section E.2.d.2.b), *Numeric Sizing Criteria for Storm Water Treatment Control BMPs*.

B.14.3 Factors Affecting Preliminary Design

Siting and design criteria are summarized in Table B-9 below.

Table B 9. Summary of Bioretention Siting and Design Criteria		
Description	Applications/Siting	Preliminary Design Factors
<p>Treatment devices designed to treat the WQV.</p> <p>Treatment Mechanisms</p> <ul style="list-style-type: none"> • Filtration through the vegetation • Sedimentation • Adsorption to soil particles • Infiltration <p>Pollutants removed</p> <ul style="list-style-type: none"> • Suspended solids • Particulate metals • Dissolved metals • Litter • Nutrients 	<ul style="list-style-type: none"> • Site must have sufficient hydraulic head to operate by gravity between the inflow and the outflow without objectionable backwater in the drainage system. • Protection of groundwater must be considered in design of Treatment BMPs. Coordinate with District/Regional NPDES Coordinator and RWQCB to identify groundwater protection areas and when high infiltration rates and high groundwater depths are present. • Separation from seasonally high water table > 5 ft., or less as justified by adequate groundwater information or RWQCB concurrence. • Bioretention device will have improved performance when its tributary area has a relatively high percentage of impervious area and low sediment loading. • Locate the bioretention device outside of the Clear Recovery Zone (<i>HDM</i> Topic 309.1), or consult with Traffic Operations for appropriate siting conditions. • Geotechnical soils investigations, such as percolation and slope stability tests, should be requested to aid in siting. • Steep slopes should be avoided unless approved by Geotechnical Design Unit. • Siting above highway fills and structures should be avoided unless Geotechnical Design Unit approval is obtained and appropriate drainage is included. 	<ul style="list-style-type: none"> • Drainage inlets and outlets, including bypass, must be designed in accordance with hydrology and hydraulics sections of the <i>HDM</i> using appropriate flood conveyance design criteria. • Bypass of flows more than the WQV is preferred to prevent scour of soil media and pollutants. Flow-through devices may also be designed. • Scour and erosion control must follow <i>HDM</i> Sections 860 and 870 criteria. • Pretreatment facilities to capture sediment in the runoff (such as with vegetation, a flow splitter with sump, forebay, etc.) are recommended. • Infiltrate WQV, or portion thereof within a maximum of 96 hours. Longer drawdown times may be allowable if vector controls meeting CDPH requirements have been implemented (e.g., underground, flap gates). When considering longer drawdown times, coordinate with the District/Regional Design Stormwater Coordinator. • Use appropriate vegetation for the site conditions (native vegetation preferred). Temporary irrigation may be needed. Consult District Landscape Architect. • Side slopes should be appropriate for soils and site conditions to prevent erosion and stability issues. • Safety of maintenance workers and maintainability of bioretention facility, as well as its buildability must all be considered. Provide maintenance access to the basin invert. Consult District Maintenance and Construction. • Bioretention BMPs can be sized for the WQV similar to Media Filters, by using continuous simulation routing, or by other appropriate civil engineering methodologies.

THIS PAGE INTENTIONALLY LEFT BLANK.

APPENDIX C: CONSTRUCTION SITE BMPS AND CHECKLISTS



THIS PAGE INTENTIONALLY LEFT BLANK.

C.1 Construction Site Best Management Practices (BMPs)

Construction Site Best Management Practices (BMPs) are applied during construction activities to reduce the pollutants in stormwater discharges throughout construction. These Construction Site BMPs provide both temporary erosion and sediment control, as well as control for potential pollutants other than sediment. There are six categories of BMPs suitable for controlling potential pollutants on construction sites. They are:

- Soil Stabilization Practices;
- Sediment Control Practices;
- Tracking Control Practices;
- Wind Erosion Control;
- Non-Stormwater Controls; and
- Waste Management and Material Pollution Controls.

To meet regulatory requirements and protect the site resources, every project must include an effective combination of Construction Site BMPs. These BMPs must be appropriately selected to meet project specific conditions and will usually represent the six categories.

Guidance and details on the use of Construction Site BMPs is available at:

- *Caltrans Construction Site Best Management Practices (BMPs) Reference Manual*;
<http://www.dot.ca.gov/hq/construc/stormwater/>

Additional description and guidance on the use of Construction Site BMPs is available at:

- *Caltrans Stormwater Pollution Prevention Plan (SWPPP) and Water Pollution Control Program (WPCP) Preparation Manual*;
<http://www.dot.ca.gov/hq/construc/stormwater/>
- *California Stormwater Quality Association (CASQA) Construction BMP Online Handbook*;
www.casqa.org/resources/bmp-handbooks
- Construction Site Best Management Practices (CS) Checklists;

Caltrans Construction Contract Standards capture most of the stormwater and water pollution control requirements in Section 13 and Section 21 of the *Standard Specifications*. The *Standard Plans* include several sheets on Construction Site BMPs. These are available at:

http://www.dot.ca.gov/hq/esc/oe/construction_standards.html

The Construction Site BMP Consideration Form on the next page is a resource for developing a Construction Site BMP strategy. Checklists for individual BMPs identified in the form can be found in this appendix.

DATE: _____

Project ID / EA: _____

Project Evaluation Process for the Consideration of Construction Site BMPs

No.	Criteria	Yes ✓	No ✓	Supplemental Information
1.	Will construction of the project result in areas of disturbed soil as defined by the Project Planning and Design Guide (PPDG)?			If Yes, Construction Site BMPs for Soil Stabilization (SS) will be required. Review CS-1, Part 1. Continue to 2. If No, Continue to 3.
2.	Is there a potential for disturbed soil areas within the project to discharge to storm drain inlets, drainage ditches, areas outside the RW, etc.?			If Yes, Construction Site BMPs for Sediment Control (SC) will be required. Review CS-1, Part 2. Continue to 3.
3.	Is there a potential for sediment or construction related materials and wastes to be tracked offsite and deposited on private or public paved roads by construction vehicles and equipment?			If Yes, Construction Site BMPs for Tracking Control (TC) will be required. Review CS-1, Part 3. Continue to 4.
4.	Is there a potential for wind to transport soil and dust offsite during the period of construction?			If Yes, Construction Site BMPs for Wind Erosion Control (WE) will be required. Review CS-1, Part 4. Continue to 5.
5.	Is dewatering anticipated or will construction activities occur within or adjacent to a live channel or stream?			If Yes, Construction Site BMPs for Non-Stormwater Management (NS) will be required. Review CS-1, Part 5. Continue to 6.
6.	Will construction include saw-cutting, grinding, drilling, concrete or mortar mixing, hydro-demolition, blasting, sandblasting, painting, paving, or other activities that produce residues?			If Yes, Construction Site BMPs for Non-Stormwater Management (NS) will be required. Review CS-1, Parts 5 & 6. Continue to 7.
7.	Are stockpiles of soil, construction related materials, and/or wastes anticipated?			If Yes, Construction Site BMPs for Waste Management and Materials Pollution Control (WM) will be required. Review CS-1, Part 6. Continue to 8.
8.	Is there a potential for construction related materials and wastes to have direct contact with stormwater; be dispersed by wind; be dumped and/or spilled into storm drain systems?			If Yes, Construction Site BMPs for Waste Management and Materials Pollution Control (WM) will be required. Review CS-1, Part 6.

C.1.1 Temporary Soil Stabilization BMPs

Temporary soil stabilization BMPs include:

- Scheduling;
- Preservation of Existing Vegetation;
- Temporary Hydraulic Mulch;
- Temporary Hydroseed;
- Temporary Soil Binder;
- Straw Mulch;
- Temporary Cover and Rolled Erosion Control Products (RECP);
- Wood Mulching;
- Earth Dikes/Drainage Swales and Lined Ditches;
- Outlet Protection/Velocity Dissipation Devices;
- Slope Drains; and
- Streambank Stabilization.

Provided in Table C-1 are selection criteria, information, and ratings for temporary soil stabilization BMPs. The BMPs are described in detail following Table C-1.

Table C 1. Temporary Soil Stabilization Criteria Matrix

Class	Type	Temporary Soil Stabilization Control Criteria											
		Antecedent Moisture	Availability	Ease of Clean-Up	EC Effectiveness (%)	Degradability	Length of Drying Time (hrs.)	Time to Effectiveness (days)	Longevity	Mode of Application	Residual Impact	Native	Runoff Effect
CATEGORY: STANDARD BIODEGRADABLE MULCHES (SBM)													
Straw Mulch	Wheat Straw	D	S	H	90-95	B	0	1	M	L/M	M		+
	Rice Straw	D	S	H	90-95	B	0	1	M	L/M	M		+
Wood Fiber Mulch	Wood Fiber	D	S	H	50-60	B	0-4	1	M	H	L		+
Recycled Paper Mulch	Cellulose Fiber	D	S	H	50-60	B	0-4	1	S	H	L		+
Bonded Fiber Matrix	Biodegradable	D	S	H	90-95	B	12-18	1	M	H	M		+
CATEGORY: ROLLED EROSION CONTROL PRODUCTS (RECP)													
Biodegradable	Jute Mesh	D	S	H	65-70	B		1	M	L	M		+
	Curled Wood Fiber	D	S	H	85-90	P/B		1	M	L	M		+
	Straw	D	S	H	85-90	P/B		1	M	L	M		+
	Wood Fiber	D	S	H	85-90	P/B		1	M	L	M		+
	Coconut Fiber	D	S	H	90-95	P/B		1	L	L	M		+
	Coconut Fiber Mesh	D	S	H	85-90	B		1	L	L	M		+
	Straw Coconut Fiber	D	S	H	90-95	P/B		1	L	L	M		+
Non-Biodegradable	Synthetic Fiber with Netting	D	M	H	90-95	P		1	L	L	H		+
	Bonded Synthetic Fibers	D	M	H	90-95	P		1	L	L	H		+
	Combination with Biodegradable	D	M	H	85-90	P		1	L	L	H		+
CATEGORY: TEMPORARY SEEDING (TS)													
High-Density	Ornamentals		S-M	H	50-60			28	M-L	H	L-M	N/E	+
	Turf species		S	H	50-60			28	L	H	M-H	N/E	+
	Bunch grasses		S-M	H	50-60			28	L	H	L-M	N	+
Fast-Growing	Annual		S	H	50-60			28	L	H	L-H	N/E	+
	Perennial		S	H	50-60			28	L	H	M	N/E	+
Non-Competing	Native		S-M	H	50-60			28	L	H	L-M	N	+
	Non-Native		S-M	H	50-60			28	L	H	L-H	E	+
Sterile	Cereal Grain		S	H	50-60			28	L	H	L	E	+
CATEGORY: IMPERVIOUS COVERS (IC)													
Plastic	Rolled Plastic Sheeting		S		100	P		1	M	L	H		-
	Geotextile (Woven)		S		90-95	P		1	M	L	H		-
CATEGORY: HYDRAULIC SOIL STABILIZERS (HSS)¹													
(PBS) Plant Material Based- Short Lived	Guar	D	S	H	80-85	B	12-18	Same as Length of Drying Time.	S	B	L		0/+
	Psyllium	P	S	H	25-35	B	12-18		M	B	L		0
	Starches	D	S	H	25-30	B	9-12		S	H	L		0
(PBL) Plant Material Based- Long Lived	Pitch/ Rosin Emulsion	D	S	M	60-75	B	19-24		M	B	M		-
	(PEB) Polymeric Emulsion Blends	Acrylic polymers and copolymers	D	S	M	35-70	P/C		19-24	L	B	M	
Methacrylates and acrylates		D	M	M	35-40	P/C	12-18		S	W	L		0/+
Sodium acrylates and acrylamides		D	M	M	20-70	P/C	12-18		S	H	L		+/-
Polyacrylamide		D	M	M	55-65	P/C	4-8		M	H	L		0/+
(PRB) Petroleum/Resin-Based Emulsions	Emulsified Petroleum Resin	D	M	L	10-50	P/C	0-4		M	H	L		0/+
		(CBB) Cementitious Based Binders	Gypsum	D	S	M	75-85		P/C	4-8	M	H	L
Follow procedures in Appendix F and use Table F-3 for cost estimates of line item BMPs													
	= not applicable for category, class, or type												
¹	= Some RWQCBs have restrictions on the use of these items.												
UNK	= unknown												
See next page for Legend													

Table C 2. Temporary Soil Stabilization Criteria Matrix (continued)

Antecedent Moisture	D P	Soil should be relatively dry before application Soil should be pre-wetted before application
Availability	S M	A short turn-around time between order and delivery, usually 3-5 days A moderate turnaround time, between 1-2 weeks
Ease of Clean-Up	L M H	Require pressure washing, a strong alkali solution, or solvent to clean up Requires cleanup with water while wet; more difficult to clean up once dry May be easily removed from equipment and overspray areas by a strong stream of water
Installed Cost		Dollars per acre
Degradability	C P B	Chemically degradable Photodegradable Biodegradable
Length of Drying Time		Estimated hours
Time to Effectiveness		Estimated days
Erosion Control Effectiveness		Percent reduction in soil loss over bare soil condition.
Longevity	S M L	1 - 3 months 3 - 12 months > than 12 months
Application Mode	L W H B M	Applied by hand labor Applied by water truck Applied by hydraulic mulcher Applied by either water truck or hydraulic mulcher Applied by a mechanical method other than those listed above (e.g., straw blower)
Residual Impact	L M H	Projected to have a low impact on future construction activities Projected to have a moderate impact on future construction activities Projected to have a significant impact on future construction activities
Native	N E	Plant or plant material native to the State of California Exotic plant not native to the State of California
Runoff Effect	+ 0 -	Runoff is decreased over baseline (bare soil) No change in runoff from baseline Runoff is increased over baseline

C.1.1.1 Scheduling

This BMP involves developing, for every project, a schedule that includes sequencing of construction activities with the implementation of Construction Site BMPs. The purpose is to reduce the amount and duration of soil exposed to erosion by wind, rain, runoff and vehicle tracking, and to perform the construction activities and control practices in accordance with the planned schedule. The Construction Contract Standards require this as part of the Contractor’s SWPPP or WPCP.

C.1.1.2 Preservation of Existing Vegetation

Preservation of existing vegetation is the identification and protection of desirable vegetation that provides erosion and sediment control benefits. Whenever practical, existing vegetation should be preserved. Plants and trees act as effective soil stabilization and sediment control devices, particularly around the perimeter of construction sites. Areas that will not be disturbed as part of construction activities should be clearly marked on plans and protected in the field with fencing. Access limitations should also be shown on the plans.

Items to consider when preserving existing vegetation include:

- Preserve existing vegetation to provide effective erosion control;
- Consider the age, life expectancy, health, aesthetic value, and habitat benefits of vegetation to be preserved;
- Areas containing vegetation to be preserved must be shown on the plans; and
- Preserve native plants on the site wherever possible.

C.1.1.3 Hydraulic Mulch

Hydraulic mulch consists of applying a water-based mixture of wood or paper fiber and stabilizing emulsion with hydro-mulching equipment. This will protect disturbed soil from erosion by raindrop impact or wind.

C.1.1.4 Hydroseed

Hydroseeding consists of applying a water-based mixture of wood or paper fiber, stabilizing emulsion, and seed with hydro-mulching equipment. Often fertilizer and compost are added to the hydraulic mixture. This will protect disturbed soil from erosion by raindrop impact or wind.

C.1.1.5 Soil Binder

Soil binders, also known as tackifiers or soil stabilizers, are adhesives that stabilize soil by binding soil particles together. This will protect disturbed soil from erosion by raindrop impact or wind. Soil binders used in combination with hydraulic mulches are called tackifiers.

There are five types of tackifiers (soil binders)¹:

- Plant Material-Based (Short-Term);
- Plant Material-Based (Long-Term);
- Polymeric Emulsion Blends;
- Petroleum or Resin-Based Emulsions; and
- Cementitious-Based Binders.

C.1.1.6 Straw Mulch

Straw mulch consists of placing a uniform layer of straw and incorporating it into the soil with a studded roller, or anchoring it with a tackifier. Straw mulch is used for temporary soil stabilization, as a temporary surface cover, on disturbed areas until soils can be prepared for re-vegetation. It is also used in combination with temporary and/or permanent seeding strategies to enhance plant establishment.

Loose straw is the most common mulch material used in conjunction with direct seeding of soil. Straw mulching is generally the second part of multi-step process where seed and fertilizer is first

¹ Some RWQCBs have restrictions on the use of these items.

applied, then straw mulch applied as the second step. The final step of the process involves holding the loose straw in place by a) using netting, b) applying a liquid tackifier, or c) punching it into the soil by a process known as “crimping” or “incorporating.”

C.1.1.7 Temporary Cover and Rolled Erosion Control Products (RECP)

This BMP involves the placement of geosynthetic fabrics (geotextiles), plastic covers, or erosion control blankets/mats to stabilize disturbed soil area (DSA) and protect soil from erosion by wind or water.

C.1.1.8 Wood Mulch

Wood mulching consists of applying shredded wood, bark, or green material. The primary function of wood mulching is to reduce erosion by protecting bare soil from raindrop impact and reducing runoff. The material is typically spread by hand, although pneumatic methods are available.

C.1.1.9 Earth Dikes/Drainage Swales and Lined Ditches

Earth dikes, drainage swales and lined ditches are structures that intercept, divert, and convey surface runoff in a controlled, non-erosive manner. Top, toe, and mid-slope diversion ditches, berms, dikes, and swales should be used to intercept runoff and direct it away from critical slopes without allowing it to reach the roadway.

Design guidelines include:

- Select design flow and safety factor based on careful evaluation of the risk due to erosion of the measure, over topping, flow backups, or wash out;
- Examine the site for run-on from off-site sources. These off-site flows shall be diverted from or passed through the construction site without contact with disturbed soils;
- Select flow velocity limit of unlined conveyance systems based on soil types and drainage flow patterns for each project site. Establish a maximum flow velocity for using earth dikes and swales, above which a lined ditch must be used (see HDM Table 862.2). Consider use of rip-rap, engineering fabric, vegetation or concrete lining;
- Consider outlet protection where localized scour is anticipated;
- Consider order of work provisions early in the construction process to effectively install and use the permanent ditches, berms, dikes, and swales; and
- A sediment-trapping device should be used in conjunction with conveyances where sediment-laden water is expected.

C.1.1.10 Outlet Protection/Velocity Dissipation Devices

Outlet protection/velocity dissipation devices are rock slope protection or other materials placed at pipe outlets to reduce flow velocity and the energy of exiting stormwater flows and to prevent scour. They are used where localized scouring is anticipated, such as outlets of pipes, drains, culverts, slope drains, diversion ditches, swales, conduits, or channels. They are also used where lined channels or ditches discharge to unlined conveyances.

Appropriate applications include:

- Outlets of pipes, drains, culverts, slope drains, diversion ditches, swales, conduits, or channels;
- Outlets located at the bottom of mild to steep slopes;
- Outlets that carry continuous flow;
- Outlets subject to short, intense flows of water, such as from flash floods; and
- Where lined conveyances discharge to unlined conveyances.

C.1.1.11 Slope Drains

A slope drain is a pipe used to intercept and direct surface runoff or groundwater into a stabilized watercourse, trapping device, or stabilized area. Slope drains should be sized to convey the applicable storm event for the construction period down or around the slope (see HDM for additional information).

C.1.1.12 Streambank Stabilization

Drainage systems including the stream channel, streambank, and associated riparian areas, are dynamic and sensitive ecosystems that respond to changes in land use activity. Streambank and channel disturbance resulting from construction activities can increase the stream's sediment load, which can cause channel erosion or sedimentation and have adverse effects on the biotic system. Reference the *HDM Section 870* and *DIB-87, Vegetated Rock Slope Protection* from HQ Office of Hydraulics and Stormwater Design (OHSD).

C.1.2 Sediment Control Practices

Sediment control is required along the site perimeter at all operational internal inlets.

Sediment control devices function by:

- Slowing water velocities, thereby allowing soil particles to settle out; and
- Attenuating the flood peak by detaining flow and releasing water at a slower rate.

All sediment control devices require continued maintenance to function properly. Excess sediment not removed reduces capacity and efficiency.

Sediment control practices include, but are not limited to:

- Silt Fence
- Sediment/Desilting Basin
- Sediment Trap/Curb Cutback
- Check Dam
- Fiber Rolls/Large Sediment Barrier
- Gravel Bag/Earthen Berm
- Street Sweeping and Vacuuming
- Sand Bag Barrier
- Straw Bale Barrier
- Drainage Inlet Protection
- Compost Sock
- Flexible Sediment Barrier

C.1.2.1 Silt Fence

A silt fence is a temporary linear sediment barrier of permeable fabric designed to intercept and slow the flow of sediment-laden sheet flow runoff. Silt fences allow sediment to settle from runoff before water leaves the construction site.

Silt fences are placed below the toe of exposed and erodible slopes, downslope of exposed soil areas, around temporary stockpiles and along streams and channels. Silt fences should not be used to divert flow or in streams, channels or anywhere flow is concentrated.

C.1.2.2 Sediment/Desilting Basin

A de-silting basin is a temporary basin formed by excavation and/or an embankment where sediment-laden runoff is temporarily detained under quiescent conditions allowing sediment to settle out before the runoff is discharged.

De-silting basins shall be considered for use:

- On construction projects with disturbed areas during the rainy season;
- Where sediment-laden water may enter the drainage system or water courses; and
- At outlets of disturbed soil areas between 5 and 10 acres.

C.1.2.3 Sediment Trap/Curb Cutback

A sediment trap is a temporary basin with a controlled release structure formed by excavating or constructing an earthen embankment across a waterway or low drainage area. As a supplemental control sediment traps provide additional protection for a water body or for reducing sediment before it enters a drainage system. A curb cutback is a temporary containment area created when the project utilizes the depression of the curb from a removed section of pavement as temporary containment to collect sediment.

Sediment traps may be used on construction projects during the rainy season when the contributing drainage area is less than 5 acres. Traps would be placed where sediment laden stormwater may enter a storm drain or watercourse, and around and/or up-slope from storm drain inlet protection measures.

C.1.2.4 Check Dam

A check dam is a small device constructed of rock, sand bags, or fiber rolls, placed across a natural or man-made channel or drainage ditch. Check dams reduce scour and channel erosion by reducing flow velocity and encouraging sedimentation.

C.1.2.5 Fiber Rolls/Large Sediment Barrier

A fiber roll consists of straw or other similar materials inserted into a tube of biodegradable netting. Fiber rolls are placed on the face of slopes at regular intervals and/or at the toe of slopes to intercept runoff, reduce its flow velocity, release the runoff as sheet flow, and provide removal of sediment from the runoff.

C.1.2.6 Gravel Bag/Earthen Berm

A gravel bag berm consists of a single row of gravel bags that are installed end-to-end to form a barrier across a slope to intercept runoff, reduce runoff velocity, release runoff as sheet flow and provide some sediment removal. The gravel bag berm should be installed along a level contour with the bags tightly abutted.

Gravel Bag Berm can also be used:

- Where flows are moderately concentrated to divert and/or detain flows;
- Along the perimeter of a site;
- Along streams and channels;
- Below the toe of exposed and erodible slopes; and
- Around stockpiles.

Earthen berms are linear sediment barriers designed to intercept sheet flows and impound water upstream of the berm, allowing sediment to settle before runoff is released.

C.1.2.7 Street Sweeping and Vacuuming

Street sweeping and vacuuming are both sediment and tracking control practices to remove tracked soil particles from paved roads to prevent the sediment from entering a storm drain or watercourse. Street sweeping and vacuuming are implemented anywhere sediment is tracked from the project site onto public or private paved roads, typically at points of egress.

C.1.2.8 Sand Bag Barrier

A sand bag barrier is a temporary linear sediment barrier consisting of stacked sand bags, designed to intercept and slow the flow of sediment-laden sheet flow runoff. Sand bag barriers allow sediment to settle from runoff before water leaves the construction site.

Sand bags can also be used:

- Where flows are moderately concentrated to divert and/or detain flows;
- Along the perimeter of a site;
- Along streams and channels;
- Below the toe of exposed and erodible slopes; and
- Around stockpiles.

C.1.2.9 Straw Bale Barrier

A straw bale barrier is a temporary linear sediment barrier consisting of straw bales, designed to intercept and slow sediment-laden sheet flow runoff. Straw bale barriers allow sediment to settle from runoff before water leaves the construction site. A common use is adjacent to a silt fence.

C.1.2.10 Drainage Inlet Protection

Drainage inlet protection is a practice to reduce sediment from stormwater runoff discharging from the construction site prior to entering the storm drainage system. Effective drainage inlet protection

allows sediment to settle out of stormwater or filters sediment from the stormwater before it enters the drain inlet. Drainage inlet protection is the last line of sediment control defense prior to stormwater leaving the construction site. Caltrans standard plans show Drainage Inlet Devices configured to protect drainage inlets under a variety of project conditions.

C.1.2.11 Compost Sock

A compost sock is a 12-inch diameter biodegradable mesh tube that is filled with compost. Compost sock placement includes and is not limited to the toe, top, face, and at grade breaks of exposed and erodible slopes, and as check dams in unlined ditches to intercept runoff, reduce its flow velocity, release the runoff as sheet flow, and provide removal of sediment from the runoff. Compost socks are susceptible to damage by traffic and compost can potentially leach nutrients into runoff and negatively affect water quality.

C.1.2.12 Flexible Sediment Barrier

Flexible sediment barriers are synthetic alternatives to fiber rolls, compost socks, and straw bale barriers. Flexible sediment barriers consist of a geosynthetic fabric with a urethane foam-filled core and fabric apron to prevent undermining and scour. Flexible sediment barrier placement includes and is not limited to check dams in ditches and channels, as inlet protection for operational storm drains to intercept runoff, reduce its flow velocity, and provide removal of sediment from the runoff.

C.1.3 Tracking Control Practices

Tracking control practices prevent or reduce off-site tracking of sediment by vehicles. Tracking is a common source of complaints, and can result in discharge of sediment to storm drains or watercourses. These measures include:

- Temporary Construction Entrance;
- Temporary Construction Roadway;
- Entrance/Outlet Tire Wash; and
- Street Sweeping and Vacuuming.

C.1.3.1 Temporary Construction Entrance

A temporary construction entrance is a designated point of access (ingress and egress) to a construction site that is stabilized to reduce tracking of sediment (mud and dirt) onto public roads by construction vehicles. See *Standard Plan T-58*. Temporary construction entrances are an effective method to limit the migration of sediment from the construction site, especially when combined with street sweeping and vacuuming. The temporary entrance is typically composed of a crushed aggregate layer over a geotextile fabric or constructed of steel plates with ribs.

C.1.3.2 Temporary Construction Roadway

A temporary construction roadway is a temporary access road connecting existing public roads to a remote construction area. It is designed for the control of dust and erosion created by vehicular traffic. A temporary construction roadway may be constructed of aggregate, asphalt concrete, or concrete based on the desired longevity.

C.1.3.3 Entrance/Outlet Tire Wash

A tire wash is an area located at stabilized construction access points to remove sediment from tires and undercarriages, and to prevent tracking of sediment onto public roads. The tire wash typically includes a wash rack on a pad of coarse aggregate. The runoff water from the wash area must be conveyed to a sediment trap or basin.

C.1.3.4 Street Sweeping and Vacuuming

Street sweeping and vacuuming are both sediment and tracking control practices to remove tracked soil particles from paved roads to prevent the sediment from entering a storm drain or watercourse. Street sweeping and vacuuming are implemented anywhere sediment is tracked from the project site onto public or private paved roads, typically at points of egress.

C.1.4 Wind Erosion Control

Wind erosion control consists of applying water or other dust palliatives as necessary to prevent or alleviate wind-blown dust. Dust control must be applied in accordance with Caltrans standard practices. Water or dust palliatives should be applied so no runoff occurs.

C.1.5 Non-Stormwater Management BMPs

The National Pollutant Discharge Elimination System (NPDES) stormwater regulations for construction sites also require that BMPs be included for control of non-stormwater discharges. Non-stormwater management measures are source controls that prevent pollution by limiting or reducing potential pollutants at their source before they come in contact with stormwater. These BMPs are also known as “good housekeeping practices.” The measures include:

- Water Conservation Practices
- Dewatering Operations
- Paving, Sealing, Sawcutting, and Grinding Operations
- Temporary Stream Crossing
- Clear Water Diversion
- Illegal Connection/ Illicit Discharge Detection and Reporting
- Potable Water/Irrigation
- Vehicle and Equipment Cleaning
- Vehicle and Equipment Fueling
- Vehicle and Equipment Maintenance
- Pile Driving Operations
- Concrete Curing
- Material and Equipment Use Over Water
- Structure Demolition/Removal Over or Adjacent to Water
- Concrete Finishing

During preparation of the project plans, it is not always possible to know where a contractor will be performing certain activities. To provide the contractor with flexibility, but to assure that proper control measures are implemented, the Construction Contract Standards cover most jobsite BMPs. This ensures that BMPs will be implemented for certain activities regardless of where on the site those activities are performed.

C.1.5.1 *Water Conservation Practices*

Water conservation practices are activities that use water during the construction of a project in a manner that avoids erosion caused by runoff and/or the transport of pollutants off the site. To ensure uniform implementation of water conservation requirements (e.g., during a drought) guidance documents and specifications are provided on the Caltrans Office Engineer website. See Appendix D.

C.1.5.2 *Dewatering Operations*

This BMP is intended to prevent the discharge of pollutants from construction site dewatering operations associated with stormwater (accumulated rain) and non-stormwater (groundwater, water from a diversion or cofferdam, etc.). Dewatering effluent that is discharged from the construction site to a storm drain or receiving water is subject to the requirements of the applicable NPDES permit but is most often regulated under a 401 Certification, or Waste Discharge Requirements (WDRs) administered by the RWQCB. Refer to the Field Guide to Construction Site Dewatering for detailed guidance for management of dewatering operations. The District/Regional NPDES Coordinator may need to coordinate with RWQCB for permitting and other requirements.

C.1.5.3 *Paving, Sealing, Sawcutting, and Grinding Operations*

Procedures that minimize pollution of stormwater runoff during paving operations include new paving and preparation of existing paved surfaces for overlays. Paving and grinding operations include handling materials, wastes and equipment associated with pavement removal, paving, surfacing, resurfacing, pavement preparation, thermoplastic striping and placing pavement markers.

C.1.5.4 *Temporary Stream Crossing*

A temporary stream crossing is a structure placed across a waterway that allows vehicles to cross the waterway during construction without contacting the water, thus reducing erosion and the transport of pollutants into the waterway. Temporary stream crossings are typically conditions of regulatory permits for work near live streams. Installation may require dewatering or temporary diversion of the stream. Temporary clear water diversion and stream crossing systems are discussed in detail in Section C.2 of this appendix.

C.1.5.5 *Clear Water Diversion*

Clear water diversion consists of a system of structures and measures that intercept clear surface water runoff upstream of a construction site, transport it around the site, and discharge it downstream with minimal water quality impact. Additional information and guidance for clear water diversion is provided in Section C.2 of this appendix.

C.1.5.6 *Illegal Connection/Illicit Discharge Detection and Reporting*

These procedures and practices are designed for construction contractors to recognize illegal connections or illegally dumped and discharged materials on a construction site and report incidents to the Resident Engineer (RE).

C.1.5.7 *Potable Water/Irrigation*

Potable water/irrigation consists of practices and procedures to reduce the discharge of potential pollutants generated from irrigation water lines, landscape irrigation, lawn or garden watering, potable water sources, water line flushing, and hydrant flushing.

C.1.5.8 Vehicle and Equipment Cleaning

This BMP consists of procedures and practices used to minimize or eliminate the discharge of pollutants from vehicle and equipment cleaning operations to storm drains or watercourses. On most construction sites, vehicle and equipment cleaning on site should be discouraged.

C.1.5.9 Vehicle and Equipment Fueling

This BMP consists of measures and practices to minimize or eliminate the discharge of fuel spills and leaks into the storm drain system or to watercourses. These measures include containment of fueling areas, spill prevention and control, drip pans or absorbent pads, automatic shut-off nozzles, vapor recovery nozzles, topping off restrictions, and leak inspection and repair.

C.1.5.10 Vehicle and Equipment Maintenance

This BMP consists of procedures and practices to minimize or eliminate the discharge of pollutants to the storm drain system or to watercourses from vehicle and equipment maintenance procedures. Practices include drip pans or absorbent pads, spill kits, dedicated maintenance areas, proper waste disposal, leak repair, and secondary containment.

C.1.5.11 Pile Driving Operations

The construction of bridges and retaining walls often includes driving piles for foundation support. Driven sheet piles are also used for shoring and cofferdam construction. Proper control and use of equipment, materials, and waste products from pile driving operations will reduce the discharge of potential pollutants to the storm drain system or watercourses.

C.1.5.12 Concrete Curing

This BMP consists of procedures that minimize pollution of stormwater runoff during concrete curing. Concrete curing includes the use of both chemical and water methods. Any element of the structure (e.g., footings, columns, abutments, stem and soffit, decks) may be subject to curing requirements.

C.1.5.13 Material and Equipment Use Over Water

This BMP consists of procedures for the proper use, storage, and disposal of materials and equipment on barges, boats, temporary construction pads, or similar locations that minimize or eliminate the discharge of potential pollutants to a watercourse. These procedures shall be implemented for construction materials and wastes (solid and liquid), soil or dredging materials, or any other materials that may be detrimental if released and apply where equipment is used over or adjacent to a watercourse.

C.1.5.14 Concrete Finishing

This BMP consists of procedures to minimize the impact that concrete finishing methods may have on stormwater runoff. Methods include sand blasting, lead shot blasting, grinding, or high pressure water blasting. Concrete finishing methods are used for bridge deck rehabilitation, paint removal, curing compound removal, and final surface finish appearances.

C.1.5.15 Structure Demolition/Removal Over or Adjacent to Water

This BMP consists of procedures to protect water bodies from debris and wastes associated with structure demolition or removal over or adjacent to watercourses. These procedures shall be

implemented for full bridge demolition and removal, partial bridge removal (e.g., barrier rail, edge of deck) associated with bridge widening projects, concrete channel removal, or any other structure removal that could potentially affect water quality.

C.1.6 Waste Management and Materials Pollution Control

The NPDES stormwater regulations for construction sites also require that BMPs be included in the project plans for waste management and materials pollution control. These are source control BMPs that prevent pollution by reducing pollutants at their source, and require a clean, well-kept site. The measures include:

- Material Delivery and Storage
- Material Use
- Stockpile Management
- Spill Prevention and Control
- Solid Waste Management
- Hazardous Waste Management
- Contaminated Soil Management
- Concrete Waste Management
- Sanitary/Septic Waste Management
- Liquid Waste Management

The Construction Contract Standards cover most of these BMPs to ensure that they will be implemented for certain activities regardless of where on the site those activities are performed.

C.1.6.1 *Material Delivery and Storage*

This BMP consists of procedures and practices for the proper handling and storage of materials in a manner that minimizes or eliminates the discharge of these materials to the storm drain system or to watercourses. These procedures include secondary containment, spill prevention and control, product labeling, quantity reduction, proper storage, material covering, training, and inventory control.

C.1.6.2 *Material Use*

This BMP consists of procedures and practices for use of construction material in a manner that minimizes or eliminates the discharge of these materials to the storm drain system or watercourses. These procedures include proper waste disposal, product labeling, proper cleaning techniques, recycling materials, reducing quantities, and application rates, spill prevention and control, training, and reduction of exposure to stormwater.

C.1.6.3 *Stockpile Management*

This BMP consists of procedures and practices to eliminate pollution of stormwater from stockpiles of soil and paving materials (such as concrete rubble, aggregate, and asphalt concrete). These procedures include locating stockpiles away from drainages, providing perimeter sediment barriers, soil stabilization, and wind erosion control measures.

C.1.6.4 *Spill Prevention and Control*

This BMP consists of procedures and practices implemented to prevent and control spills in a manner that minimizes or prevents the discharge of spilled material to storm drain systems or watercourses. Spill prevention and prompt appropriate spill response reduce the potential for polluting receiving waters with spilled contaminants. Spills of concern include chemicals and hazardous wastes such as soil stabilizers/binders, dust palliatives, herbicides, growth inhibitors,

fertilizers, de-icing products, fuels, lubricants, paints, and solvents. Spill prevention practices include education as well as cleanup and storage procedures that address small spills, semi-significant spills, and significant/hazardous spills.

C.1.6.5 *Solid Waste Management*

This BMP consists of procedures and practices to minimize or eliminate the discharge of pollutants to storm drain systems or watercourses as a result of the creation, stockpiling or removal of construction site wastes. Solid wastes include such items as used brick, mortar, timber, steel, vegetation/landscaping waste, empty material containers, and litter. Measures include education as well as collection, storage, and disposal practices.

C.1.6.6 *Hazardous Waste Management*

This BMP consists of procedures and practices to minimize or eliminate the discharge of pollutants from construction site hazardous waste to the storm drain system or watercourses. Hazardous wastes should be collected, stored, and disposed of using practices that prevent contact with stormwater. The following types of wastes are considered hazardous; petroleum products, concrete curing compounds, palliatives, septic wastes, paints, stains, wood preservatives, asphalt products, pesticides, acids, solvents, and roofing tar. There may be additional wastes on the project that are considered hazardous. It is also possible that non-hazardous waste could come into contact with these hazardous wastes, such that they become contaminated and are therefore considered hazardous waste. Measures include education, storage procedures, and disposal procedures.

C.1.6.7 *Contaminated Soil Management*

This BMP consists of procedures and practices to minimize or eliminate the discharge of pollutants to the storm drain system or watercourses from contaminated soil. Typical soil contamination is due to spills, illicit discharges, and underground storage tank leaks, or aerially deposited lead (ADL). Contaminated soils tend to occur on projects in urban or industrial areas. Soil contaminants and locations are often identified in the project plans and specifications. Measures include identifying contaminated areas, education, handling procedures for material with ADL, handling procedures for contaminated soils, procedures for underground storage tank removals, and water control.

C.1.6.8 *Concrete Waste Management*

This BMP consists of procedures and practices that are implemented to minimize or eliminate the discharge of concrete waste materials to the storm drain system or to watercourses. These measures include education, concrete slurry waste handling procedures, on-site concrete washout facility, transit truck washout procedures, and procedures for removal of temporary concrete washout facilities.

C.1.6.9 *Sanitary/Septic Waste Management*

This BMP consists of procedures and practices to minimize or eliminate the discharge of construction site toilet facilities to the storm drain system or watercourse. Measures include education, and storage and disposal procedures.

C.1.6.10 Liquid Waste Management

This BMP includes procedures to prevent pollutants related to non-hazardous liquid wastes from entering storm drains or receiving waters. Liquid wastes include drilling slurries, drilling fluids, wastewater that is free from grease and oil, dredging, and other non-stormwater liquid discharges not covered by separate permits. This BMP does not apply to the following:

- Dewatering operations
- Solid wastes
- Hazardous wastes
- Concrete slurries

C.2 Clear Water Diversion

C.2.1 Introduction

Clear water diversions include a variety of structures and BMPs used to intercept surface water upstream of a construction project site. The water itself may vary in clarity based on the background water quality of the stream. The purpose of the diversion is to divert the water around the construction area to provide a dry work area and to discharge the water downstream with minimal impact to water quality.

C.2.1.1 Overview

The design of these clear water diversion systems must focus on keeping work areas dry and providing overall protection of water quality. Temporary stream diversion systems commonly used for these types of projects are diversion channels, berms, dikes, slope drains, rock, gravel bags, wood, sheet piles, water filled barriers, cofferdams, filter fabric, turbidity curtains, culverts, pipes, flumes, and pumps. Stream diversions vary in size, flow, and volume with the variety and variability of California's geography, meteorology, and physiographic regions. This range of conditions results in a variety of environments, habitats, and species, which must be considered in the design. These environmental considerations are then used by the regulatory agencies and attached to permits for the control, operation, and monitoring of in water systems to allow construction of highways and highway related infrastructure. The range of diversions can be small ephemeral creeks to large rivers, which require much different levels of risk to worker safety and the environment. Project Engineers (PEs) may be tasked with designing a stream diversion system to obtain environmental permits or in other cases a lump sum system specification can be used where the design of the system is determined by the construction contractor. The designer must include the appropriate plans, specifications, design, schedule, and estimate based on the variety of parameters that may occur for this type of work.

C.2.1.2 Caltrans Project Delivery Staff Coordination

As a PE, coordination with a variety of functional units may be required. The PDT for a smaller application, may be Environmental, Right of Way, Hydraulics, Maintenance, Construction and the PE. For larger projects the coordination will need to include all of the above and engineering services for estimating and potentially designing the larger stream or river diversion system. This may require expert A&E consulting for the design of complicated and higher risk projects. Techniques for large coffer dams are included in the *Caltrans Engineering Services Structure Construction Foundation*

Manual 2010, Section 4-15. Larger projects also tend to have more impacts and thus coordination with more functional units and experts may be required for mitigating these impacts.

C.2.1.3 CGP/ NPDES Compliance SWPPP/WPCP Documentation

These systems are considered BMPs by the regulatory agencies and they must be documented in the Stormwater Pollution Prevention Plan. The project SWPPP must be submitted through the SWRCB SMARTS system as plan sheets to demonstrate to regulatory agencies what is being built. Plan sheets may be developed either by the Department or the contractor.

C.2.1.4 Appropriate Uses

As an isolation technique for creating dry work areas to prevent the water and soil to mix while construction equipment is active.

Channel diversion: For small streams where there is adequate right of way to create a temporary channel around a construction work area and geotextiles or rock can be used to handle the shear stresses associated with the expected flows.

Berms: Typically used on small perennial, intermittent, or ephemeral streams with temporary culverts or pipe diversions. Shifting flows to one side or the other within a channel.

Gravel Bag berms (some may call this a small coffer dam). Appropriate for smaller streams where the hydraulic forces and water pressure can be adequately addressed with weight of gravel bags and plastic sheeting.

Coffer Dams: Appropriate for all streams and lakes to confine flows to one side, to create dry work area, or to berm entire small streams. Typically, this terminology is used in association of structures at Caltrans, some small inflatable coffer dams may be used for smaller applications.

Pipe Diversion: Short term projects with little base flow.

Pumped Diversion: Short term projects with little base flow or where siting space restrictions prevent other options.

C.2.2 Factors Affecting Preliminary Design

C.2.2.1 Design Considerations

Does the construction of the temporary diversion system cause more environmental damage to the riparian, wetland, or 100-year flood plain area, than to construct the project without the diversion BMP? This is a consideration for all projects, but is usually appropriate for short term construction projects for temporary or ephemeral streams, where scheduling of the project when the stream is dry, may be more effective than the construction of a large diversion system in a sensitive environmental area, where construction equipment could disturb fragile vegetation, roots, sensitive species, soil structure, and root systems.

Stream Hydrology Considerations: Stream channel geometry, tributary watershed area, stream bed material, and predicted flow rates during construction. Follow methods in HDM Section 810 for the appropriate methods and rates for sizing the temporary diversion system.

Sizing the temporary diversion. In the past many temporary diversion system guidance documents required mandatory minimum return storms for sizing the systems, for example the 2-year, 5-year, or 10-year 24-hour return period. This can result in temporary diversion system as large as the drainage system they are replacing and result in large impacts to the stream riparian zone, with large disturbed soil areas. Overly conservative approaches for the hydrology sizing to protect the environment can inadvertently cause other impacts to the environment for its construction. Each project should be sized for the appropriate risks.

In coordination with District Hydraulics, consider the consequences for diversion exceedance in determining appropriate sizing including; public safety, work safety, environment, legal, regulatory permit requirements, costs, space, and schedule.

Permits: Section 404, Section 401, and Section 1600 permits will likely be required for work in jurisdictional waters.

C.2.2.2 Hydrology Methods for Sizing

The sizing of clear water diversion systems varies by the time of year, local hydrology, and duration of the diversion. If there is a prescriptive storm size in a permit document, then design to the required event size. A 2-year 24-hour storm event has been used by many as a default event, but more recent studies have shown that this may oversize the system and cause more disturbance in the sensitive stream zone than is necessary. Careful analysis of the local hydrology history and risk analysis is required to minimize the diversion impacts. However, if larger work windows are required, close consideration with District Hydraulics is advised.

C.2.2.3 Limitations

Temporary stream diversion: The designer should consider the size, depth of water, and risks. Use this BMP and specification for small streams and low risk projects.

Coffer dams and more elaborate systems should be designed by engineering services staff with the appropriate structural background or by the contractor. The design decision and design parameters should be coordinated by the PDT, so that all permitting and highway design requirements are met.

C.2.2.4 Standards and Specifications

Most small stream diversions can be designed by the district and coordinated with OHSD. In many cases the diversion can be located on the plan sheet referencing the non-standard specification for Temporary Creek Diversion.

- Include in Water Pollution Control Sheets or Drainage Plans
- Cost estimate for the Temporary Stream Diversion is usually done as a lump sum item.
- The lump sum cost estimate for temporary stream diversion will be based on the added or deleted paragraph items in the specification.
- Many projects will have multiple culverts, so it may be appropriate to develop a table of the lump sum costs for each system, this should be provided to the Resident Engineer to help review the Temporary Stream Diversion Control Plan, to help them determine if all needed items are included.

The types of diversion for small to medium sized streams may include:

- Pumped systems
- Temporary culverts
- Inflatable Cofferdams: Consult HQ Drainage Design for specification.

For larger (large rivers, lakes, bays, and ocean areas) clear water diversions that have a higher risk to worker safety and a more extensive design is required to address the forces for the depth and flow of the water, the district's structures representative should be consulted for the design. One example of these projects are larger rivers where coffer dams are required, the engineer must consult and follow the Caltrans Engineering Services Shoring Guidance and also consult with Construction as the owner of the specification.

- Diversion can be constructed from timber, soil, or steel. But in most cases are designed and constructed with steel sheet piles. Refer to 19-3.03C Cofferdams (sheet piles).
- Guidance: *Caltrans Shoring Guide* (Engineering Services)
- Dewatering: 13-4.03G of the Standard Specifications for use with coffer dams or other large in-water work.
- May need to treat or control seepage water prior to discharge, consult appropriate requirements for treatment design needs.

C.3 Active Treatment Systems

C.3.1 Introduction

Active Treatment Systems (ATS) apply conventional water treatment technologies, in use for over a century, to stormwater quality. The *Construction General Permit* (CGP) does not require the use of an ATS, but for waters and sites where the reliability of the stormwater is of concern, these systems may be used.

C.3.1.1 Overview

An ATS may be considered for a Project under the following conditions:

- When necessary to meet water quality objectives (WQO) of the receiving water, or
- When necessary to meet the effluent limits of the CGP for turbidity and pH in stormwater.

An ATS uses a coagulant or flocculent for the treatment of water with a sedimentation basin for turbidity reduction. In addition, pH adjustment or bag/cartridge/sand filters may be included. The exact configuration of the ATS will be dependent on the anticipated quality of the water to be treated and receiving water requirements.

Coagulation and sedimentation can be used to destabilize suspended particles and remove them from suspension. There are many different coagulants for use; each coagulant may use different chemical properties and may be more or less suited for different types of water qualities to be treated. Any coagulant residual in the discharge must be monitored and managed to attain any applicable effluent limits prior to discharge.

An ATS is recommended to remove particles below 0.02 mm. For locations which need to meet strict turbidity requirements an ATS system may be warranted. Particular water bodies may be listed for other parameters of concern for which an ATS might be recommended to treat any additional constituents of concern; however, not all pollutants can be treated with readily available ATS components.

C.3.1.2 Construction General Permit

An ATS under the CGP is strictly used for the treatment of stormwater discharges generated from precipitation that falls on the construction area during a storm event. Other water generated from construction operations is considered non-stormwater and is not applicable without permit authorization and consideration of additional design parameters. In some cases, designers may wish to include non-stormwater in the ATS system, if so, any non-stormwater comingled with stormwater will alter the water quality of the discharge, thus modifications of system will need to be evaluated.

Under the CGP, an ATS is recommended for use at high risk work sites, including those with limited space for sizing proper containment and detention facilities. According to Attachment K of the CGP:

“Where stormwater discharges leaving the site may cause or contribute to an exceedance of a water quality standard, the use of an Active Treatment System (ATS) may be necessary. Additionally, it may be appropriate to use an ATS when site constraints inhibit the ability to construct a correctly sized basin, when clay and/or highly erosive soils are present, or when the site has very steep or long slope lengths.”

C.3.2 ATS Selection Criteria

ATS selection will be driven by the permit-calculated risk, the available area, and the soil type of the site. Each of these will drive the selection of an ATS that would reliably meet the requirements of the CGP.

C.3.2.1 Determine Risk

Initially the project needs to identify the risk level (RL). Risk is calculated based upon the combination of the estimated sediment load potential and the sensitivity of the receiving water. Locations which have the potential to generate high concentration of sediment in the stormwater (soils which erode easily) may be classified as Risk Level 2. Locations where the receiving water is sensitive to sediment loading may also be classified as Risk Level 2. For sites where both are of concern, Risk Level 3 may be appropriate.

Projects designated as “RL 1” should proceed with typical Construction Site BMPs for stormwater mitigation. For RL 2 and 3, a selection procedure is used to determine if traditional BMPs are sufficient or if an ATS is appropriate for use.

C.3.2.2 Potential Storage Area and Peak Stormwater Flow

Construction sites with sufficient area available may be able to properly store enough water to avoid active treatment. These areas can be used for storage of water with enough detention time to settle significant quantities of particles prior to discharge. The minimum detention time can be determined by dividing the available storage by the peak flow expected from the 5-year 24-hour storm. If the

detention time of a sedimentation basin can meet the minimum compliance requirements for sedimentation, an ATS is not required for turbidity removal.

Determine the area available for potential stormwater storage (A_p). The area is not simply the total area of the construction site but the area available for storage. These can include assigned stormwater treatment locations, existing storage areas, or space outside of the construction footprint which is available for use.

C.3.2.3 Soil Type

The minimum detention time required for a construction site will depend on the predominant soil type. Fine soils, such as clay, will remain suspended for much longer times than coarser soils, such as sand. To determine the minimum detention time required, the composition of the soil within the construction site must be determined and minimum detention time evaluated depending on the result.

C.3.2.4 Settling Velocity and Required Settling Area

Calculate the minimum area for potential treatment must be made. Initially calculate the peak stormwater flow from the site based upon disturbed construction area and the rainfall intensity from a 5-year 24-hour storm event using the Rational Equation (though this peak flow does not need to be the design flow of a potential ATS). Next, determine the predominate soil type within the construction area. Conservative estimates will use the minimum particle diameter of each soil type (sand, silt, or clay) in conjunction with Stokes Law to determine the settling velocity of the sediment. Other methods or models may be substituted for Stokes Law if more information is readily available on the soils in the construction area. Dividing the peak flow by the settling velocity will determine the minimum area required (A_r) for settling without active treatment.

C.3.2.5 Determine Appropriate Device

Comparing the minimum area required (A_r) to the potential area available (A_p) will determine whether an ATS may be necessary. If the area available is significantly larger (>20 percent) than the area required, at a minimum, a detention basin can be designed to meet the stormwater quality requirements, though other BMPs may function equally well depending on the site characteristics. If the area required is significantly large than the area available (>20 percent) then an ATS must be considered. If the area available and the area required fall between the two, only RL 3 sites should consider ATS as they require more reliability than RL 2 sites. If other options are available, such as increasing potential storage area or improving the accuracy of the settling velocity calculation, the procedure can be used to re-evaluate the site. If no other options are available, an ATS is recommended.

Appendix F of the CGP contains direction for implementation of ATS. Risk level 2 projects do not have NELs for pH and turbidity, unless ATS is used. Therefore, careful evaluation is necessary before selection; check with the District/Regional Design Stormwater Coordinator. Figure C-1 shows the decision diagram for the ATS selection procedure.

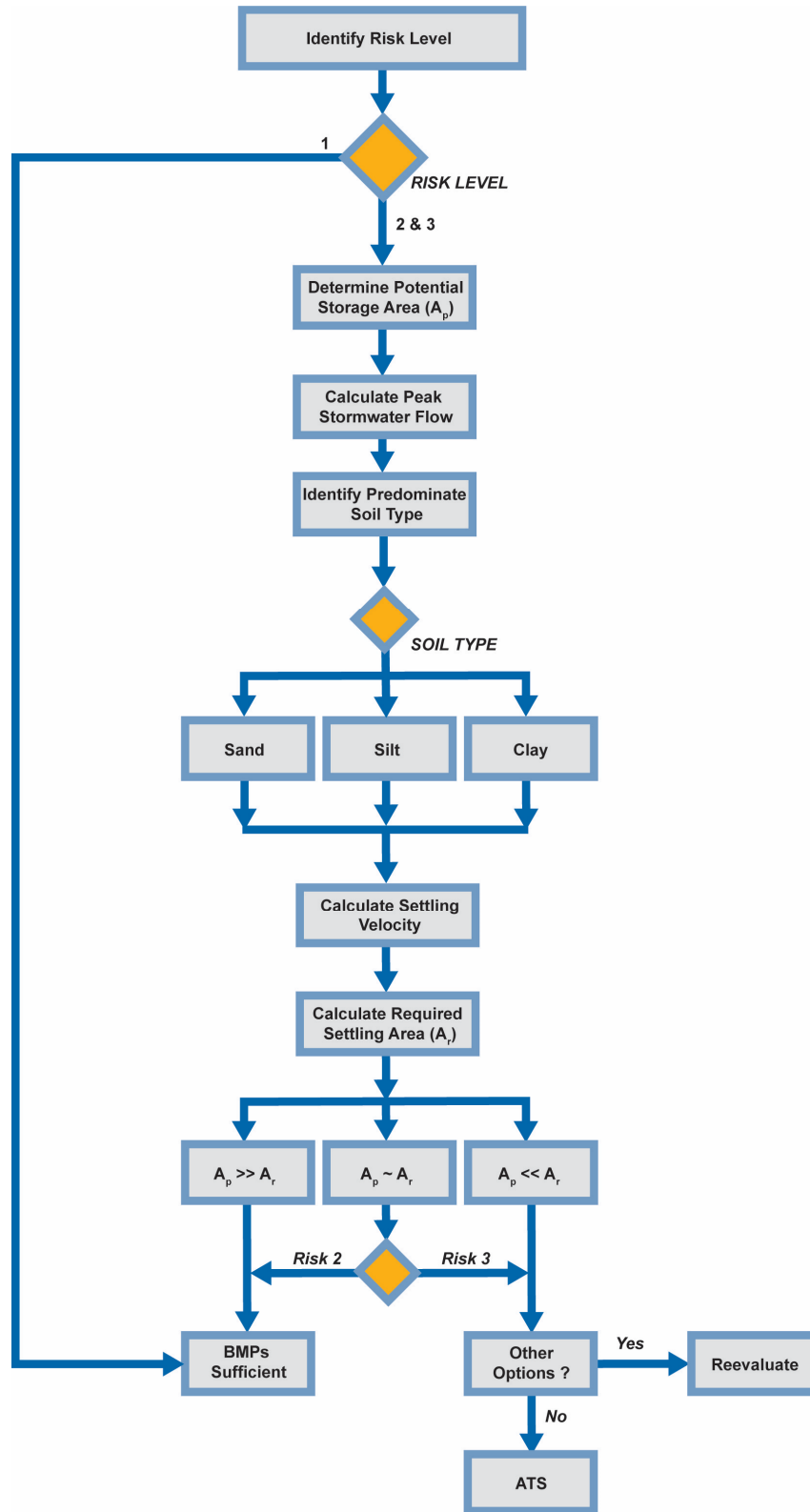

Figure C-1. Active Treatment System Decision Tree



C.3.3 Factors Affecting Preliminary Design**C.3.3.1 Pollution Prevention/Sediment Mitigation**

Actions to reduce the quantity of sediment in stormwater directed to storage should be implemented in the work area regardless of the decision to use an ATS. With an ATS these measures can lead to more efficient treatment and operational cost savings. For example, minimization of disturbed soil area can prevent significant sediment loading. Closing off or stabilizing unused portions of the site will reduce the amount of stormwater that could be impacted by construction activities.

To prevent significant sediment loading to an ATS all applicable Construction Site BMPs, especially those that provide erosion and sediment control at the source and within conveyances should be implemented.

C.3.3.2 Collection System/Discharge Piping

Collection piping is required to convey the water generated onsite to the treatment system (i.e., the ATS and its component systems). The size and quantity of piping will be determined by the layout and terrain of the disturbed construction area. It may be necessary to include pumps to move large quantities of water depending on the site layout. It is also possible for the site to implement multiple ATS systems. Discharge piping and pumps are required to convey treated water to the appropriate discharge location. Proper sizing is required to prevent flow backup or sedimentation within the pipe.

C.3.3.3 Storage/Pre-Sedimentation

It is necessary to store large quantities of water onsite during significant rain events. Locations such as swales, basins, and other areas conducive for storage may be used to retain water prior to treatment. These locations provide an additional benefit of settling out some sediment before treatment with an ATS. Design of these storage locations should be conducted in accordance with criteria for those BMPs.

Systems with a high sediment loading may necessitate a designed pretreatment tank. Pretreatment typically consists of a pre-sedimentation basin such as a weir tank for the removal of easily settleable sediment loads. Pretreatment can improve coagulant usage and effectiveness, as well as reduce the quantity of coagulant sludge, thus minimizing costs and potential concerns of the coagulant being detected in receiving waters. Systems with pre-sedimentation and storage can be sized to smaller peak flows as large storms can be stored and treated over longer durations. The trade-off will depend on both the amount of storage and design capacity of the system.

C.3.3.4 Treatment Components

Different components may be used within the ATS. These components interact with each other and need to be considered individually and as an integrated treatment system. Recirculation piping will be necessary to meet turbidity and pH discharge requirements.

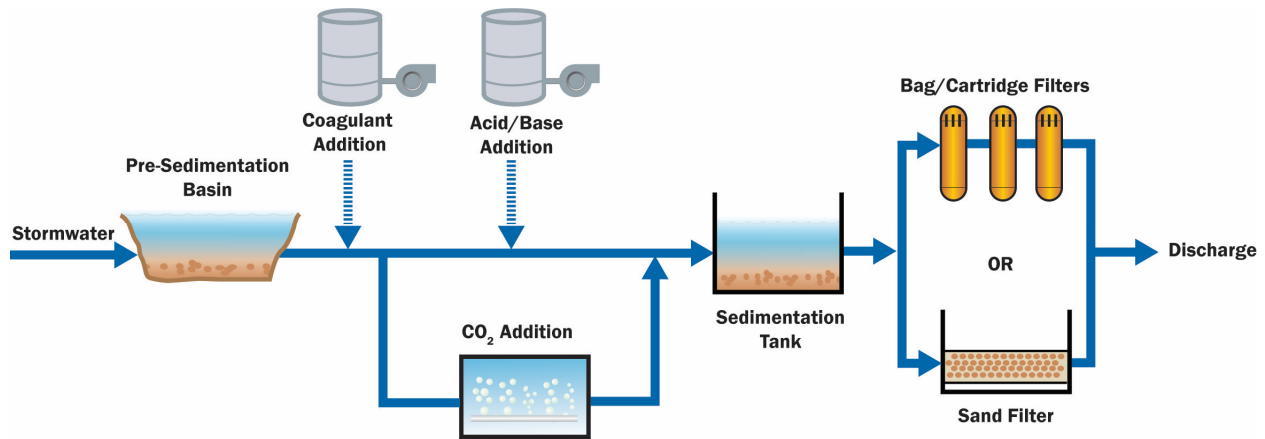

Figure C-2. Potential Treatment Schematic

Table C 3. Potential ATS Components	
Component	Use
Coagulant Dosing Equipment	Chemical for forming floc and removing turbidity
pH Adjustment Dosing Equipment	Chemical for adjusting pH within proper range
Sedimentation Tank	Gravity particulate removal and sludge removal/collection
Bag/Cartridge/Media Filters	Filters for particle removal

C.3.3.4.1 Coagulation /Flocculation

Different coagulants are available for use within an ATS system. The choice of a coagulant is an important consideration to achieve turbidity removal requirements. The anticipated water quality of the site will define which coagulants may be effective at forming floc and reducing turbidity. Coagulant dosing rates and usage will vary depending on the water quality, flow volumes, and coagulant selection.

Some coagulants that have been used on past projects include Chitosan, Ferric Chloride, and Alum. Use of other coagulants/polymers may be more difficult for the RWQCB to approve due to uncertainties about potential effects on water quality. Regardless of the coagulant choice, monitoring of residual coagulant in the discharge would likely be required.

Equipment such as a chemical feed pump, a rapid mixer (static or mechanical), and sufficient sedimentation will be necessary to properly dose any coagulant. A streaming current detector should be used to monitor and adjust coagulant dose.

A Coagulant Prevention Plan (CPP) should be required for any coagulant used in order to ensure protection from potentially toxic effects on both human and wildlife from high concentration coagulant exposure. At a minimum, the CPP should include coagulant storage, monitoring, and disposal during the lifespan of the ATS.

Table C 4. Potential ATS Chemicals				
Class of Chemical	Chemical	Advantages	Disadvantages	Approximate Cost
pH Decrease	Hydrochloric Acid (HCl)	Low Dose	Safety Concerns	
	Sulfuric Acid (H ₂ SO ₄)	Low Dose	Safety Concerns	
	Carbon Dioxide (CO ₂)	Inert, Self-Buffering	Mechanically Intensive, Requires Diffuser/Basin	
pH Increase	Sodium Hydroxide (NaOH)	Low Dose	Safety Concerns	
Coagulant / Flocculent	Alum	Lower Cost	Drops pH, Can Require High Dose	
	Ferric (Chloride/Sulfate)	Lower Cost	Drops pH, Can Require High Dose	
	Chitosan	Low Dose	May Not Work Well for Certain Soils	\$2,500 per Tote

C.3.3.4.2 pH Adjustment

For certain systems, pH adjustment may be necessary to maintain receiving water integrity. Certain sites conditions, such as fresh concrete or other chemicals used onsite, may adversely affect pH. Furthermore, certain coagulant choices can alter pH. There are multiple methods for pH adjustment depending on the water quality of the site.

Carbon Dioxide (CO₂) can be used to lower the pH. CO₂ gas is bubbled through water forming carbonic acid (H₂CO₃) and thereby reducing pH. Carbon dioxide is mechanically more intensive, but the gas is much safer to store onsite. The CO₂ system requires a bubble diffuser and a separate basin for proper implementation.

Strong acids and bases may also be used. Dosing generally occurs alongside coagulant addition. Dosing rates will vary depending on water quality, receiving water quality, and acid/base selection. Strong acids/bases have safety concerns associated with storage and dosing. In addition, acid/base selection is important to prevent possible interactions with other treatment components. Strong acids (e.g., hydrochloric acid, sulfuric acid) and bases (e.g., sodium hydroxide) would provide rapid pH response for most waters; another advantage to all the acids and bases listed in the table below is that the corresponding counter-ions (e.g., sulfate, chloride, sodium) are not expected to react with constituents in the treatment system. In contrast, some acids (e.g., citric acid) introduce counter ions (citrate) that can have undesirable side-effects, such as promoting bacterial growth or inhibiting floc formation.

Table C 5. Suggested pH Adjustment Chemicals	
Acids	Bases
Carbon Dioxide (CO ₂) – Bubble Carbon Dioxide will form carbonic acid and drop pH	Sodium Hydroxide (NaOH)
Sulfuric Acid (H ₂ SO ₄) – strong acid	
Hydrochloric Acid (HCl)	

C.3.3.4.3 Sedimentation Tanks

Sedimentation tanks are required to settle floc formed from coagulation. Sedimentation tanks must provide sufficient surface area and retention time to allow adequate settling of solids. Tanks as opposed to weir tanks are recommended for use with high sediment loads. Weir tanks may be used for systems that have minimal influent sediment loading. Higher sediment loads will quickly fill weir tanks and would require sludge removal at higher frequencies compared to sedimentation tanks.



Figure C-3. Sedimentation Tank (Devil's Slide)

C.3.3.4.4 Bag/Cartridge/Media Filter

Bag, cartridge, or media filters provide additional particle removal prior to discharge. Bag and cartridge filters pass water through mesh filters reducing particle sizes to a predetermined size. Media filters use sand or other granular media to remove particles. Bag and cartridge filters are removed, changed out and discarded. Media filters use treated water to backwash the filter and remove particles.

It may be necessary to reduce turbidity to approximately 25 NTU or below prior to filtration to prevent excessive buildup on the filter. For bag and cartridge filters, higher turbidity levels passed to the filters will cause increased frequency of change-out. For sand filters, more frequent backwashing will be required which will cause greater work, more chemical usage, and more clean water for backwashing.



Figure C-4. Bag/Cartridge Filters (Devil's Slide)

C.3.3.4.5 Power Sources

An Uninterruptible Power Supply and standby electric generator is recommended for any ATS system. Storms can routinely interrupt power supply systems, thus it is necessary to provide a backup in such circumstances.

C.3.3.4.6 SCADA Monitoring Equipment

Supervisory Control and Data Acquisition (SCADA) systems are standard technology used to monitor and control all monitoring and mechanical systems within an ATS. These systems can record and store all relevant data to the project. Remote operation of an ATS is possible through SCADA systems, but connection stability must be maintained to ensure proper operation.

ATS effluent discharges should meet the requirements of the CGP. Monitoring equipment must be installed. These include, but are not limited to, turbidimeter, pH meters, and flow meters. These meters need to be calibrated as recommended by the manufacturer or regulator. The frequency of calibration and a documented process to retrieve and verify data should be specified to the contractor and may be required of the RWQCB. In addition, some water quality analysis will need to be conducted by outside labs for analysis such as total suspended solids (TSS), settleable solids (SS), or residual coagulant.

C.3.4 Active Treatment System Sizing

The size of the treatment system will be dependent on the acreage of the active disturbed soil area. The system is required to be sized for a 10-year 24-hour storm as required by the Standard Specification. Storms that are greater than the design storm may cause the ATS to exceed the CGP restrictions. In these circumstances, the RWQCB will still expect the contractor to make efforts for meeting the CGP or other requirements.

C.3.4.1 Construction Area

The area of the basin will be defined by the contributing drainage area of the disturbed construction site. The contributing drainage areas will be defined by the designer depending on the orientation of the construction site. For long or flat construction sites, it may be necessary to subdivide the site and set up separate ATS locations. The conveyance systems required to funnel stormwater to a central ATS location may be prohibitive for certain site orientations.

If multiple receiving waters are present in the site, each receiving water basin may require a separate ATS in order to maintain watershed integrity. For some receiving waters, BMPs may be sufficient to meet turbidity goals, for others an ATS system may be warranted.

C.3.4.1.1 Flowrate

Peak flowrate can be calculated for each area by the Rational Formula:

$$Q = C \times I \times A \quad (\text{Eqn. 1})$$

Q = Peak Runoff Rate, Cubic Feet per Second

C = Dimensionless Runoff Coefficient

I = Rainfall intensity, Inches per Hour (10-yr, 24-hr storm)

A = Basin Area, Acres

The rainfall intensity will vary by project location.

The dimensionless runoff coefficient will be determined by the designer based upon worst case conditions for the construction site.

Basin area will be considered based upon the total area of the sub area in question.

C.3.4.1.2 Sedimentation Residence Time

$$\text{HRT} = V/Q \quad (\text{Eqn. 2})$$

HRT = Hydraulic Retention Time, Hours

V = Volume of Sedimentation Basin, Gallons

Q = Flowrate, Gallons per Hour

Hydraulic Retention Time should be between 2-4 hours in order to settle sufficient floc to meet turbidity requirements.

C.4 Construction Site (CS) BMP Checklists

Checklist CS-1, Parts 1 – 6 are provided on the following pages to assist the PE in developing the Construction Site BMP strategy and completing the Construction Site BMPs section of the project SWDR. The checklists are provided as a tool for CS BMP consideration purposes only. When used, the checklists should be kept in the project file, and not attached to the SWDR, unless requested by the District/Regional Design Stormwater Coordinator.



Construction Site BMPs		
Checklist CS-1, Part 1		
Prepared by: _____	Date: _____	District-Co-Route: _____
PM: _____	Project ID/EA: _____	RWQCB: _____

Temporary Soil Stabilization

General Parameters

1. How many rainy seasons are anticipated between begin and end of construction? _____
2. What is the total disturbed soil area for the project? (ac) _____
3. Consult your District/Regional Design Stormwater Coordinator for the minimum required combination of temporary soil stabilization and temporary sediment controls and barriers for area, slope inclinations, rainy and non-rainy season, and active and non-active disturbed soil areas. Complete

Scheduling

4. Does the project have a duration of more than one rainy season and have disturbed soil area in excess of 25 acres? Yes No
 - (a) Include multiple mobilizations (Move-in/Move-out) as a separate contract bid line item to implement permanent erosion control or revegetation work on slopes that are substantially complete. (Estimate at least 6 mobilizations for each additional rainy season. Designated Construction Representative may suggest an alternate number of mobilizations.) Complete
 - (b) Edit specifications for permanent erosion control or revegetation work to be implemented on slopes that are substantially complete. Complete
 - (c) Edit permanent erosion control or revegetation specifications to require seeding and planting work to be performed when optimal. Complete

Preservation of Existing Vegetation

5. Do Environmentally Sensitive Areas (ESAs) exist within or adjacent to the construction limits? (Verify the completion of DPP-1, Part 5) Yes No
 - (a) Verify the protection of ESAs through delineation on all project plans. Complete
 - (b) Protect from clearing and grubbing and other construction disturbance by enclosing the ESA perimeter with high visibility plastic fence or other BMP. Complete

6. Are there areas of existing vegetation (mature trees, native vegetation, landscape planting, etc.) that need not be disturbed by project construction? Will areas designated for proposed or existing Treatment BMPs need protection (infiltration characteristics, vegetative cover, etc.)? (Coordinate with District Environmental and Construction to determine limits of work necessary to preserve existing vegetation to the maximum extent practicable.) Yes No
- (a) Designate as outside of limits of work (or designate as ESAs) and show on all project plans. Complete
- (b) Protect with high visibility plastic fence or other BMP. Complete
7. If yes for 5, 6, or both, then designate ESA fencing as a separate contract bid line item, if not already incorporated as part of design pollution prevention work (See DPP-1, Part 5). Complete

Slope Protection

8. Provide a temporary soil stabilization BMP(s) appropriate for the DSA, slope steepness, slope length, and soil erodibility. (Consult with District Landscape Architect.)
- (a) Select Hydraulic Mulch, Hydroseeding, Soil Binders, Straw Mulch, Geotextiles, Mats, Plastic Covers, and Erosion Control Blankets, Wood Mulching, other BMPs or a combination to cover the DSA throughout the project's rainy season. Complete
- (b) Increase the quantities by 25 percent for each additional rainy season. (Designated Construction Representative may suggest an alternate increase.) Complete
- (c) Designate as a separate contract bid line item. Complete

Slope Interrupter Devices

9. For projects with temporary erosion control requirements, provide slope interrupter devices for all slopes with slope lengths equal to or greater than of 20 ft in length, in accordance with CGP requirements.
- (a) Select Fiber Rolls or other BMPs to protect slopes throughout the project's rainy season. Complete
- (b) For slope inclination of 4:1 (h:v) and flatter, Fiber Rolls or other BMPs shall be placed along the contour and spaced 20 ft on center. Complete
- (c) For slope inclination between 4:1 (h:v) and 2:1 (h:v), Fiber Rolls or other BMPs shall be placed along the contour and spaced 15 ft on center. Complete
- (d) For slope inclination of 2:1 (h:v) and greater, Fiber Rolls or other BMPs shall be placed along the contour and spaced 10 ft on center. Complete



- (e) Increase the quantities by 25 percent for each additional rainy season. (Designated Construction Representative may suggest alternate increase.) Complete
- (f) Designate as a separate contract bid line item. Complete

Channelized Flow

- 10. Identify locations within the project site where concentrated flow from stormwater runoff can erode areas of soil disturbance. Identify locations of concentrated flow that enters the site from outside of the RW (off-site run-on). Complete
 - (a) Utilize Geotextiles, Mats, Plastic Covers, and Erosion Control Blankets, Earth Dikes/Swales, Ditches, Outlet Protection/Velocity Dissipation, Slope Drains, Check Dams, or other BMPs to convey concentrated flows in a non-erosive manner. Complete
 - (b) Designate as a separate contract bid line item, as appropriate. Complete

Construction Site BMPs		
Checklist CS-1, Part 2		
Prepared by: _____	Date: _____	District-Co-Route: _____
PM: _____	Project ID/EA: _____	RWQCB: _____

Sediment Control

Perimeter Controls - Run-off Control

1. Is there a potential for sediment laden sheet and concentrated flows to discharge offsite from runoff cleared and grubbed areas, below cut slopes, embankment slopes, etc.? Yes No
 - (a) Select linear sediment barrier such as Silt Fence, Fiber Rolls, Gravel Bag Berm, Sand Bag Barrier, Straw Bale Barrier, or a combination to protect wetlands, water courses, roads (paved and unpaved), construction activities, and adjacent properties. (Coordinate with District Construction for selection and preference of linear sediment barrier BMPs.) Complete
 - (b) Increase the quantities by 25 percent for each additional rainy season. (Designated Construction Representative may suggest an alternate increase.) Complete
 - (c) Designate as a separate contract bid line item. Complete

Perimeter Controls - Run-on Control

2. Do locations exist where sheet flow upslope of the project site and where concentrated flow upstream of the project site may contact DSA and construction activities? Yes No
 - (a) Utilize linear sediment barriers such as Earth Dike/Drainage Swales and Lined Ditches, Fiber Rolls, Gravel Bag Berm, Sand Bag Barrier, Straw Bale Barrier, or other BMPs to convey flows through and/or around the project site. (Coordinate with District Construction for selection and preference of perimeter control BMPs.) Complete
 - (b) Designate as a separate contract bid line item, as appropriate. Complete

Storm Drain Inlets

3. Do existing or proposed drainage inlets exist within the construction limits? Yes No
 - (a) Select Drainage Inlet Protection to protect municipal storm drain systems or receiving waters wetlands at each drainage inlet. (Coordinate with District Construction for selection and preference of inlet protection BMPs.) Complete
 - (b) Designate as a separate contract bid line item. Complete

4. Can existing or proposed drainage inlets utilize an excavated sediment trap as described in Drainage Inlet Protection - Type 2? Yes No
- (a) Include with other types of Drainage Inlet Protection. Complete

Sediment/Desilting Basin

5. Does the project lie within a Rainfall Area where the required combination of temporary soil stabilization and sediment control BMPs includes desilting basins? Yes No
- (a) Consider feasibility for desilting basin allowing for available right-of-way within the construction limits, topography, soil type, disturbed soil area within the watershed, and climate conditions. Document if the inclusion of sediment/desilting basins is infeasible. Complete
- (b) If feasible, design desilting basin(s) per the guidance in the *CASQA Construction BMP Guidance Handbook* to maximize capture of sediment-laden runoff. Complete
- (c) Designate as a separate contract bid item Complete
6. Is ATS to be used for controlling sediment? Yes No
- (a) If yes, then will desilting basin or other means of natural storage be used? Yes No
- (b) If no, then plan for storage tanks sufficient to hold treatment volume. Complete
7. Will the project benefit from the early implementation of proposed permanent Treatment BMPs? (Coordinate with District Construction.) Yes No
- (a) Edit specifications for permanent Treatment BMP work to be implemented in a manner that will allow its use as a Construction Site BMP. Complete

Sediment Trap

8. Can sediment traps be located to collect channelized runoff from disturbed soil areas prior to discharge? Yes No
- (a) Design sediment traps in accordance with the *CASQA Construction BMP Guidance Handbook*. Complete
- (b) Designate as a separate contract bid line item. Complete

Construction Site BMPs		
Checklist CS-1, Part 3		
Prepared by: _____	Date: _____	District-Co-Route: _____
PM: _____	Project ID/EA: _____	RWQCB: _____

Tracking Controls

Stabilized Construction Entrance/Exit

1. Are there points of entrance and exit from the project site to paved roads where mud and dirt could be transported offsite by construction equipment? (Coordinate with District Construction for selection and preference of tracking control BMPs.) Yes No
 - (a) Identify and designate these entrance/exit points as stabilized construction entrances. Complete
 - (b) Designate as a separate contract bid line item. Complete

Tire/Wheel Wash

2. Are site conditions anticipated that would require additional or modified tracking controls such as entrance/outlet tire wash? (Coordinate with District Construction.) Yes No
 - (a) Designate as a separate contract bid line item. Complete

Stabilized Construction Roadway

3. Are temporary access roads necessary to access remote construction activity locations or to transport materials and equipment? (In addition to controlling dust and sediment tracking, access roads limit impact to sensitive areas by limiting ingress, and provide enhanced bearing capacity.) (Coordinate with District Construction.) Yes No
 - (a) Designate these temporary access roads as stabilized construction roadways. Complete
 - (b) Designate as a separate contract bid line item. Complete

Street Sweeping and Vacuuming

4. Is there a potential for tracked sediment or construction related residues to be transported offsite and deposited on public or private roads? (Coordinate with District Construction for preference of including street sweeping and vacuuming with tracking control BMPs.) Yes No
 - (a) Designate as a separate contract bid line item. Complete

Construction Site BMPs		
Checklist CS-1, Part 4		
Prepared by: _____	Date: _____	District-Co-Route: _____
PM: _____	Project ID/EA: _____	RWQCB: _____

Wind Erosion Controls

Wind Erosion Control

1. Is the project located in an area where standard dust control practices in accordance with *Standard Specifications*, Section 14-903: Dust Control, are anticipated to be inadequate during construction to prevent the transport of dust offsite by wind? Yes No
(Note: Dust control by water truck application is paid for through the various items of work. Dust palliative, if it is included, is paid for as a separate item.)
 - (a) Select Hydraulic Mulch, Hydroseeding, Soil Binders, Geotextiles, Mats, Plastic Covers, and Erosion Control Blankets, Wood Mulching or a combination to cover the DSA subject to wind erosion year-round, especially when significant wind and dry conditions are anticipated during project construction. (Coordinate with District Construction for selection and preference of wind erosion control BMPs.) Complete
 - (b) Designate as a separate contract bid line item. Complete



Construction Site BMPs		
Checklist CS-1, Part 5		
Prepared by: _____	Date: _____	District-Co-Route: _____
PM: _____	Project ID/EA: _____	RWQCB: _____

Non-Stormwater Management

Temporary Stream Crossing & Clear Water Diversion

1. Will construction activities occur within a water body or watercourse such as a lake, wetland, or stream? (Coordinate with District Construction for selection and preference for stream crossing and clear water diversion BMPs.) Yes No
 - (a) Select from types offered in Temporary Stream Crossing to provide access through watercourses consistent with permits and agreements.¹ Complete
 - (b) Select from types offered in Clear Water Diversion to divert watercourse consistent with permits and agreements.¹ Complete
 - (c) Designate as a separate contract bid line item(s). Complete

Other Non-Stormwater Management BMPs

2. Are construction activities anticipated that will generate wastes or residues with the potential to discharge pollutants? Yes No
 - (a) Identify potential pollutants associated with the anticipated construction activity and select the corresponding BMP such as Water Conservation Practices, Dewatering Operations, Paving and Grinding Operations, Potable Water/Irrigation, Vehicle and Equipment Cleaning, Vehicle and Equipment Fueling, Vehicle and Equipment Maintenance, Pile Driving Operations, Concrete Curing, Material and Equipment Use Over Water, Concrete Finishing, and Structure Demolition/Removal Over or Adjacent to Water.¹ Complete
 - (b) Verify that costs for non-stormwater management BMPs are identified in the contract documents. Designate BMP as a separate contract bid line item if the requirements in Job Site Management *Standard Specifications* Section 13 are anticipated to be inadequate or if requested by Construction. Complete

¹ Coordinate with District Environmental for consistency with US Army Corps of Engineers 404 and 401 permits and Dept. of Fish and Game 1601 Streambed alteration Agreements.

Construction Site BMPs		
Checklist CS-1, Part 6		
Prepared by: _____	Date: _____	District-Co-Route: _____
PM: _____	Project ID/EA: _____	RWQCB: _____

Waste Management & Materials Pollution Control

Concrete Waste Management

1. Does the project include concrete placement or mortar mixing? Yes No
- (a) Select from types offered in Concrete Waste Management to provide concrete washout facilities. In addition, consider portable concrete washouts and vendor supplied concrete waste management services. (Coordinate with District Construction for selection and preference of waste management and materials pollution control BMPs.) Complete
- (b) Designate as a separate contract bid line item if the quantity of concrete waste and washout are anticipated to exceed 5.2 yd³ or if requested by Construction. Complete

Other Waste Management and Materials Pollution Controls

2. Are construction activities anticipated that will generate wastes or residues with the potential to discharge pollutants? Yes No
- (a) Identify potential pollutants associated with the anticipated construction activity and select the corresponding BMP such as Material Delivery and Storage, Material Use, Spill Prevention and Control, Solid Waste Management, Hazardous Waste Management, Contaminated Soil Management, Sanitary/Septic Waste Management, and Liquid Waste Management Complete
- (b) Verify that costs for waste management and materials pollution control BMPs are identified in the contract documents. Designate BMP as a separate contract bid line item if the requirements in Job Site Management *Standard Specifications* Section 13 are anticipated to be inadequate or if requested by Construction. Complete

Temporary Stockpiles (Soil, Materials, and Wastes)

3. Are stockpiles of soil, etc. anticipated during construction? Yes No
- (a) Verify that costs for stockpile management and associated sediment control and temporary soil stabilization BMPs for temporary stockpiles are identified in the contract documents. Designate as a separate contract bid line item if the requirements in Job Site Management *Standard Specifications* Section 13 are anticipated to be inadequate or if requested by Construction. Complete

APPENDIX D: RELEVANT STORMWATER DOCUMENTS, WEBSITES, AND PROCESS SUMMARY FORMS

- Relevant Stormwater Documents
- Stormwater Related Websites
- PID Process Summary Forms
- PA/ED Process Summary Forms
- PS&E Process Summary Forms



THIS PAGE INTENTIONALLY LEFT BLANK.

Table D 1. Relevant Stormwater Documents and Purpose		
Date	Document	Purpose
July 2016	Statewide Stormwater Management Plan (SWMP)	Policy Document that ties the functional area activities together and describes the procedures and practices to address stormwater quality statewide. It identifies how Caltrans will comply with the provisions of the National Pollutant Discharge Elimination System (NPDES) permit.
March 2003 (update scheduled for Fall 2016)	Storm Water Quality Handbooks: Construction Site Best Management Practices (BMPs) Manual	Provides instructions for the selection and implementation of Construction Site BMPs. Caltrans requires contractors to identify and utilize these BMPs in the preparation of their SWPPP or WPCP.
September 2008	Erosion Prediction Procedure Manual	Describes the method established and approved by OHSD for the prediction of erosion rates before, during, and after construction of Caltrans projects to meet the erosion and sediment control requirements identified in the Caltrans Permit and CGP.
June 2011	Storm Water Quality Handbooks: Storm Water Pollution Prevention Plan (SWPPP) and Water Pollution Control Program (WPCP) Preparation Manual	Guides contractors and Caltrans staff through the process of preparing a SWPPP and WPCP. This manual provides detailed step-by-step procedures, instructions, examples and a template that contractors shall use to prepare the SWPPP/WPCP.
June 2012	Water Quality Assessment Guidelines (WQAG) and Templates for the Water Quality Assessment Report (WQAR)	Provides guidance on preparing WQARs as well as methods for assessing stormwater quality impacts of a project in support of preparing the PA/ED.
February 2016, October 2011	Caltrans Project Development Procedures Manual and Guide to Project Delivery Workplan Standards	The planning and design approach described in the PPDG has been developed to fit within the appropriate Work Breakdown Structure codes found in these documents.
July 2013	Caltrans NPDES Statewide Stormwater Permit	Regulates stormwater discharges from Caltrans right-of-way during and after construction, as well as from existing facilities and activities.
July 2012	Construction General Permit	Permit for construction activities applicable to all stormwater discharges from projects that result in soil disturbance of at least one (1) acre.
Varies	Regional Board Water Quality Control Plans (Basin Plans)	Identifies designated beneficial uses and water quality objectives for specific jurisdictional regions.
December 2015	Model Water Efficient Landscape Ordinance Guidance	Describes the requirements of different project landscape related project elements.
April 2012	Project Risk Level Determination Guidance	Provides a complete methodology for determining project risk level.
February 2016	Design Guidance for Final Soil Stabilization	Provides guidance in methods to document final soil stabilization, the Method Demonstration Form, and permanent erosion control strategy.
February 2013	Caltrans Infiltration Tool Guidance	Provides guidance to estimate infiltration provided by specific BMPs.
Varies	Caltrans Treatment BMP Design Guidance	Provides guidance on sizing and design of approved Treatment BMPs.
August 2014	Caltrans Pervious Pavement Design Guidance	Provides guidance on use and design of pervious pavement.
February 2015	Caltrans Hydromodification Requirements Guidance	Describes how to perform a rapid stability assessment and describes higher level analysis.
December 2015	Caltrans Highway Design Manual	Uniform policies and procedures to carry out the design functions of the Department.
May 2015	Runoff Coefficient Evaluation for Volumetric BMP Sizing	Describes the Small Storm Hydrology Method and use with water quality volume calculations for the smaller Water Quality event.
September 2012	Caltrans Stormwater Quality Handbook: Maintenance Staff Guide	Provides details on the use of Maintenance BMPs.

Table D 2. Stormwater Related Websites

Website	Description
http://www.dot.ca.gov/hq/oppd/stormwtr/index.htm	Web site for HQ Office of Hydraulics and Stormwater Design (OHSD) includes links to guidance, tools (Basin Sizer, WQPT), training, studies, etc.
http://www.dot.ca.gov/hq/oppd/storm1/caltrans_20090729.html	Treatment BMP Guidance
http://www.dot.ca.gov/hq/oppd/stormwtr/training.htm	Office of Hydraulics and Stormwater Design – Training Materials
http://www.swrcb.ca.gov/water_issues/programs/stormwater/caltrans.shtml	Caltrans NPDES Statewide Stormwater Permit (Caltrans Permit)
http://www.dot.ca.gov/hq/env/stormwater/index.htm	Caltrans Statewide Stormwater Program – HQ DEA (contains links such as Annual Report, SWMP, Regional Work Plans, 2012 Water Quality Assessment Report Content and Recommended Format Template)
http://www.swrcb.ca.gov/water_issues/programs/stormwater/construction.shtml	Construction General Permit (General Permit)
http://www.dot.ca.gov/hq/construc/stormwater/	Division of Construction - Stormwater Quality Link. Contains links to resources for developing SWPPP, WPCP, the Stormwater Quality Information Handout, and Construction Site Dewatering.
http://www.dot.ca.gov/hq/construc/stormwater/manuals.htm	Caltrans Construction Stormwater Quality Manuals and Handbooks
http://www.dot.ca.gov/hq/oppd/cadd/usta/ppman/default.htm	Caltrans Plans Preparation Manual
http://www.dot.ca.gov/hq/esc/oe/specs_html/index.html	Caltrans Construction Contract Standards (Specifications, Plans, Standard Special Provisions (SSPs).
http://www.dot.ca.gov/hq/projmgmt/documents/wsg/wsg_r10-1_july_31_2009.pdf	Guide to Project Delivery Workplan Standards – Release 10.1
http://www.dot.ca.gov/hq/oppd/pdpm/pdpmn.htm	The Project Development Procedures Manual
http://www.epa.gov	U.S. Environmental Protection Agency (EPA)
https://www.cdph.ca.gov/	California Department of Public Health (CDPH)
http://www.gpo.gov/fdsys/browse/collectionCfr.action?collectionCode=CFR	Code of Federal Regulations (CFR)
https://www.sustainablehighways.dot.gov/FHWA_Sustainability_Activities_June2014.aspx	Federal Highway Administration – Sustainable Highways Initiative
http://resources.ca.gov/ceqa/	California Environmental Quality Act (CEQA)
http://resources.ca.gov/ceqa/guidelines/art19.html	CEQA web site that lists Categorical Exemptions
http://www.dot.ca.gov/hq/oppd/costest/costest.htm	Caltrans Cost estimating guidance
http://www.water.ca.gov/waterdatalibrary/groundwater/index.cfm	Aquifer groundwater quality and seasonal groundwater levels: monitoring well data, U.S. Geological Survey (USGS), Department of Water Resources (DWR) and local public agency maps and databases.
http://www.dot.ca.gov/ser/	This website is the Standard Environmental Reference (SER) which is an online resource to help state and local agency staff plan, prepare, submit, and evaluate environmental documents for transportation projects. The site includes five Environmental Handbooks, as well as guidance, forms, templates and memos pertaining to the environmental process at Caltrans.
http://www.dwr.water.ca.gov	California Department of Water Resources web site that provides data regarding: Water quality; groundwater level; climatology, and surface water.
http://cdoncdc.noaa.gov/climatenormals/clim20/state-pdf/ca.pdf	National Oceanic and Atmospheric Administration (NOAA) – (climate Information such as CA monthly climate summaries)
http://www.dot.ca.gov/hq/oppd/hdm/hdmtoc.htm	Caltrans Highway Design Manual



Table D 3. Summary of Stormwater Activities for Project Initiation Document (PID)				
Work Breakdown Structure (WBS) Code	Activity	Stormwater Quality Planning Activity During the PID Phase	Date(s) Completed	Completed By
100.05	Project Management - PID Process	Invite District/Regional Design Stormwater Coordinator and District/Regional NPDES Coordinator to project kickoff meeting and to participate in the Project Development Team (PDT).		
100.05.10	PDT meetings	The PDT should meet throughout the entire project in order to maintain communication and to obtain consensus between the functional units throughout the project. Any decisions made during the PDT meetings should be documented.		
150.05.05	Site Data Sources	<p>Complete Checklist SW-1 (Site Data Sources)</p> <p>From Section 4, determine if project is required to consider incorporating Treatment BMPs.</p> <ul style="list-style-type: none"> • Complete Evaluation Documentation Form (Appendix E). • If the project is not required to consider Treatment BMPs, verify with District/Regional Design Stormwater Coordinator. Continue with the PID process with the selection of Design Pollution Prevention and Construction Site Best Management Practices (BMPs). • If the project is required to consider Treatment BMPs, select Treatment, Design Pollution Prevention and Construction Site BMPs. 		
150.05.20	Define Stormwater Design Issues	<p>Obtain any existing available data.</p> <p>After obtaining existing data and selecting project alternatives, determine potential stormwater quality impacts and issues. Obtain additional data from the different functional units.</p> <ul style="list-style-type: none"> • Complete Checklist SW-2 (Stormwater Quality Issues Summary) <p>Perform Field Review of the Area</p> <p>Begin Filling out the Stormwater Data Report (SWDR).</p> <p>Coordinate with District/Regional NPDES Coordinator to identify potential water quality impacts.</p> <p>Coordinate with Environmental Unit during preparation of the PEAR.</p> <p>Evaluate options for avoiding or reducing potential impacts. Begin to fill out Checklist SW-3, Measures for Avoiding or Reducing Potential Stormwater Impacts.</p>		
150.10	Identify Potential BMPs	<p>Determine Potential/Likely BMPs for each site of impact to receiving waters.</p> <ul style="list-style-type: none"> • Complete Checklist DPP-1 (including all applicable parts 1-5) and T-1 (including all applicable parts 1-1.1) for selecting BMPs at specific sites. 		

Table D 3. Summary of Stormwater Activities for Project Initiation Document (PID)				
Work Breakdown Structure (WBS) Code	Activity	Stormwater Quality Planning Activity During the PID Phase	Date(s) Completed	Completed By
150.10.05	RWQCB Meetings	<p>Consultation with the Regional Water Quality Control Board (RWQCB) is strongly recommended to coordinate project issues and develop consensus for controversial or complex stormwater quality issues.</p> <p>Initiate meetings with the RWQCB as necessary. Number of coordination meetings is entirely dependent upon the complexity of the stormwater quality issues, stormwater pollutants involved, and project site constraints. District/Regional NPDES Coordinator serves as the single point of contact with the RWQCB.</p>		
150.15	Analyze Project Alternatives	Discuss BMPs with District/Regional Design Stormwater Coordinator, Landscape Architecture and District Maintenance Stormwater Coordinator.		
150.15.55	Project Planning Cost Estimate (PPCE)	<p>Develop preliminary BMP costs and incorporate into the PID cost estimate.</p> <p>Evaluate for Construction Site BMP costs.</p> <ul style="list-style-type: none"> • Refer to cost estimating procedure in Appendix F. • Meet with Construction to obtain concurrence with the Construction Site BMP strategy – cost estimate. 		
150.25.25	Stormwater Data Report (SWDR)	<p>Route SWDR for functional units' signature.</p> <p>Coordinate with the Environmental Unit.</p> <p>Complete the SWDR using available data.</p>		
150.25	Prepare and Approve PID	Incorporate "Stormwater Pollution Prevention Discussion" under "Considerations" heading of the planning document.		
150.25.20	Circulate, Review, and Approve PID	Attach signed SWDR cover sheet to PID and circulate to obtain functional unit concurrence. Original copy of SWDR should be kept in the project file.		

Table D 4. Summary of Stormwater Activities for Project Approval/Environmental Document (PA/ED)				
WBS Code	Activity	Stormwater Quality Planning Activity During the PA/ED Phase	Date(s) Completed	Completed By
100.10	Project Management Process (PA/ED)	Invite District/Regional Design Stormwater Coordinator and District/Regional NPDES Coordinator to project kickoff meeting and to participate in the PDT.		
100.10.10	PDT meetings	The PDT should meet throughout the entire project in order to maintain communication and to obtain consensus between the functional units throughout the project. Any decisions made during the PDT meetings should be documented.		
160.05	Review and Update Project Information	<p>Confirm whether or not the project is required to consider incorporating Treatment BMPs for the preferred alternative.</p> <ul style="list-style-type: none"> • Complete/Update Evaluation Documentation Form (Appendix E). • If the project is not required to consider Treatment BMPs, verify with District/Regional Design Stormwater Coordinator. Continue with selection of Design Pollution Prevention and Construction Site BMPs. • If the project is required to consider Treatment BMPs, select Treatment, Design Pollution Prevention, and Construction Site BMPs. <p>Review Information Developed in the PID Process. Determine potential stormwater quality impacts and issues for project alternatives. Obtain updated data and reports from the different functional units.</p> <ul style="list-style-type: none"> • Update Checklist SW-1 (Site Data Sources) • Update Checklist SW-2 (Stormwater Quality Issues Summary). <p>Consult with Environmental Unit to coordinate the PA/ED Phase - SWDR with the WQAR prepared by Environmental (WBS 165.10.35). Perform Field Review of the Area. Update SWDR.</p> <ul style="list-style-type: none"> • Evaluate options for avoiding or reducing potential impacts. Update Checklist SW-3, Measures for Avoiding or Reducing Potential Stormwater Impacts. 		

Table D 4. Summary of Stormwater Activities for Project Approval/Environmental Document (PA/ED)				
WBS Code	Activity	Stormwater Quality Planning Activity During the PA/ED Phase	Date(s) Completed	Completed By
160.10	Revise Potential BMP Selections Based on Engineering Studies	<p>Select Potential/Likely BMPs for each site of unavoidable impact to receiving waters.</p> <ul style="list-style-type: none"> • Complete Checklist DPP-1 (including all applicable parts 1-5) and T-1 (including all applicable parts 1-11) for selecting BMPs at specific sites. <p>Coordinate with Environmental Unit to coordinate the PA/ED – Phase SWDR with the WQAR prepared by Environmental.</p> <p>Discuss BMPs with District/Regional Design Stormwater Coordinator, Maintenance Stormwater Coordinator, and other functional units (e.g., Hydraulics, LA) to obtain concurrence.</p> <p>Evaluate potential Construction Site BMPs.</p> <ul style="list-style-type: none"> • See Construction Site BMPs Manual. • Meet with District/Regional NPDES Coordinator to discuss BMPs for project required by RWQCB or other agency. <ul style="list-style-type: none"> • Meet with Construction to obtain concurrence with the Construction Site BMP strategy. 		
165.10.35	RWQCB Meetings	<p>Consult with the RWQCB to coordinate project issues and develop consensus for controversial or complex stormwater quality issues.</p> <p>Initiate meetings with the RWQCB through the District/Regional NPDES Coordinator as necessary. The number of coordination meetings is entirely dependent upon the complexity of the stormwater quality issues, stormwater pollutants involved, and project site constraints.</p>		
160.15	Prepare Draft Project Report (DPR)	<p>Incorporate “Stormwater Pollution Prevention Discussion” under “Considerations” heading of the planning document. (This is done only if the project does not have categorical exemption and has an Environmental Document (ED))</p>		
180.05.15	Stormwater Data Report (SWDR)	<p>Coordinate with the Environmental Unit.</p> <p>Complete the SWDR using available data.</p> <p>Route SWDR for functional units’ signature.</p>		
160.15.05	Update Project Planning Cost Estimates	<p>Develop preliminary BMP costs and incorporate into PA/ED cost estimate.</p>		
180.05.05	Prepare and Approve Project Report (PR)	<p>Attach signed SWDR cover sheet to PR and circulate to obtain functional unit concurrence. Original copy of SWDR should be kept in the project file.</p>		

Table D 5. Summary of Stormwater Activities for Plans, Specifications & Estimates (PS&E)				
WBS Code	Activity	Stormwater Quality Planning Activity During the PS&E Phase	Date(s) Completed	Completed By
100.15	Project Management Process (PS&E)	Invite District/Regional Design Stormwater Coordinator and District/Regional NPDES Coordinator to project kickoff meeting and to participate in the PDT.		
100.15.10	PDT Meetings	The PDT should meet throughout the entire project in order to maintain communication and to obtain consensus between the functional units throughout the project. Any decisions made during the PDT meetings should be documented.		
205.10.40	RWQCB Meetings	Consult with the RWQCB to coordinate project issues and develop consensus for controversial or complex stormwater quality issues. Initiate meetings with the RWQCB through the District/Regional NPDES Coordinator as necessary. The number of coordination meetings is entirely dependent upon the complexity of the stormwater quality issues, stormwater pollutants involved, and project site constraints.		
185.05	Review and update project information	Review Information Developed in the PID and PA/ED Process. <ul style="list-style-type: none"> • Update Checklist SW-1 (Site Data Sources) • Update Checklist SW-2 (Stormwater Quality Issues Summary) Consult with Environmental Unit to obtain permits. Perform Field Review of the Area. Review and Update the SWDR; if a WQAR is prepared for the project, reference the WQAR findings. Evaluate options for avoiding or reducing potential impacts. Update Checklist SW-3, Measures for Avoiding or Reducing Potential Stormwater Impacts.		
185.15	Perform Preliminary Design	Perform Preliminary Design. <ul style="list-style-type: none"> • Delineate drainage areas and total disturbed area. • Review and update need to consider Treatment BMPs. • Obtain Engineering Reports, WBS 185.20, from the different functional units. 		
205.00	Obtain Necessary Permits, WDRs and Agreements	Obtain NPDES Stormwater Permits and Local Agency Agreements. <ul style="list-style-type: none"> • File Notice of Intent (NOI) for coverage under the Caltrans Permit. • Obtain Waste Discharge Requirement (WDR) for Aerially Deposited Lead (ADL) reuses. • Coverage for dewatering activities under separate NPDES permit. Contact your District/Regional NPDES Coordinator. • Obtain other agreements with RWQCB and other agencies. 		

Table D 5. Summary of Stormwater Activities for Plans, Specifications & Estimates (PS&E)				
WBS Code	Activity	Stormwater Quality Planning Activity During the PS&E Phase	Date(s) Completed	Completed By
230.00 230.35 230.40	Prepare Draft PS&E - Design Pollution Prevention BMPs	Prepare Draft PS&E - Design Pollution Prevention BMPs. <ul style="list-style-type: none"> • Update Checklist DPP-1 (and all applicable Parts 2-5) • Incorporate Design Pollution Prevention BMPs in all applicable plans, specifications, and estimates. • Review with District Landscape Architect and District Maintenance as necessary. • Calculate quantities, estimates, and prepare Standard Special Provisions (SSPs). 		
230.00 230.35 230.40	Prepare Draft PS&E - Treatment BMPs	Prepare Draft PS&E - Design Treatment BMPs. <ul style="list-style-type: none"> • Update Checklist T-1, Part 1 • Update all applicable Checklist T-1, Parts 2-11 • Incorporate Treatment BMPs in all applicable plans, specifications, and estimates. • Hydraulics to design or review design as per HDM requirements. • Review Treatment BMPs and future maintenance with District/Regional Design Stormwater Coordinator and Maintenance Stormwater Coordinator. • Calculate quantities, estimates, and prepare SSPs. 		
230.00 230.35 230.40	Prepare Draft PS&E - Construction Site BMPs	Prepare Draft PS&E - Construction Site BMPs. <ul style="list-style-type: none"> • Review Appendix C of the PPDG and the Construction Site BMP Manual. • Complete Construction Site BMPs Consideration Form and respective Checklists CS-1, Parts 1-6 • Meet with District/Regional NPDES Coordinator to discuss BMPs for project required by RWQCB or other agency. • Meet with Construction on inclusion of Construction Site BMPs. • Calculate quantities, estimates, and prepare SSPs. 		
230.60.05	Stormwater Data Report	Complete and stamp SWDR. Route for functional unit concurrence.		
255.20	Prepare Final District PS&E Package	Attach signed SWDR cover sheet for the PS&E package and obtain functional unit signature. Original copy of the SWDR should be kept in the project file.		
255.40	Prepare RE File	Submit a signed copy of the SWDR to Resident Engineer (RE) File. Consult with Design and Construction Stormwater Coordinators for materials to include in the Stormwater Information Handout or RE File.		

Table D 6. Summary of Stormwater Activities During Construction				
WBS Code	Activity	Stormwater Quality Planning Activity During the PS&E Phase	Date(s) Completed	Completed By
280.00	Admin of PLACS & Environ Stewardship			
280.10		PLAC Compliance		
280.40		Plac Violation		
280.50		Other Environmental Compliance		
280.60		Other Environmental Violations		
280.70		Updated Environmental Commitments Record		
280.75		Environmental Reevaluation		
280.80		Updated PLACS		

THIS PAGE INTENTIONALLY LEFT BLANK.

APPENDIX E: STORMWATER DATA REPORT AND CHECKLISTS

- Stormwater Data Report Instructions
- Short Form - Stormwater Data Report Template
- Long Form – Stormwater Data Report Template
- Evaluation Documentation Form
- SWDR Attachment for SMARTS Input
- Checklist SW-1, Site Data Sources
- Checklist T-1, Part 1 (Treatment BMPs)
- Checklist SW-2, Stormwater Quality Issues Summary
- Checklist SW-3, Measures for Avoiding or Reducing Stormwater Impacts



THIS PAGE INTENTIONALLY LEFT BLANK.

Stormwater Data Report (SWDR)

Depending upon the extent of soil disturbance and degree of stormwater impacts, a “Long Form” or “Short Form” SWDR shall be required. Projects that do not have the potential to create stormwater impacts, and have little or no soil disturbance may utilize the “Short Form” SWDR. The District/Regional Design Stormwater Coordinator makes the final decision on the type of form to use. A Short Form SWDR may be appropriate for (but not limited to) the following types of projects:

- Signing and striping projects;
- Weigh-in-motion projects;
- Traffic monitoring projects (closed-circuit camera installation, etc.);
- Construction of ADA ramps;
- Bridge rail projects;
- Chip seal and/or fog seal projects;
- Pavement marker projects (raised or depressed);
- Metal Beam Guardrail Projects;
- Loop detector installations;
- Median Barrier Projects;
- Extended plant establishment projects and other planting projects;
- Emergency projects¹ using informal bids (as defined per PDPM);
- Building remodeling or refurbishment such as painting, tile, or plumbing repair;
- Small Maintenance Projects (CEQA exempt);
- Approach Slab Replacement;
- Paint Striping;
- Overlay existing and shoulder backing;
- Utility trenches;
- Cold Plane and Resurfacing;
- Micro surfacing;
- Culvert Lining (without CWA 404/401); and
- Culvert Replacement (without CWA 404/401).

¹ Note that an Emergency Project done under Force Account does not require a SWDR.



Dist-County-Route: _____
 Post Mile Limits: _____
 Project Type: _____
 Project ID (EA): _____
 Program Identification: _____
 Phase: PID PA/ED PS&E

Regional Water Quality Control Board(s): _____

1. Does the project disturb 5 or more acres of soil? Yes No
2. Does the project disturb 1 or more acres of soil and not qualify for the Rainfall Erosivity Waiver? Yes No
3. Is the project required to implement Treatment BMPs? Yes No
4. Does the project impact existing Treatment BMPs? Yes No

If the answer to any of the preceding questions is “Yes”, prepare a Long Form – Stormwater Data Report. Unless otherwise agreed upon by the District/Regional Design Stormwater Coordinator.

Total Disturbed Soil Area: _____ New Impervious Surface: _____
 Estimated Const. Start Date: _____ Estimated Const. Completion Date: _____
 Risk Level: RL 1 RL 2 RL 3 Not Applicable
 Is MWELO applicable? Yes No

This Short Form – Stormwater Data Report has been prepared under the direction of the following Licensed Person. The Licensed Person attests to the technical information contained herein and the data upon which recommendations, conclusions, and decisions are based. Professional Engineer or Landscape Architect stamp required at PS&E only.

[Name], Registered Project Engineer/Landscape Architect Date

I have reviewed the stormwater quality design issues and find this report to be complete, current, and accurate:

[Stamp Required at PS&E only]

[Name], District/Regional Design SW Coordinator or Designee Date

1. Project Description

- Clearly describe the type of project and major engineering features.
- Describe how the following values were calculated:
 - Total disturbed soil area (DSA)
 - New impervious surface (NIS)
 - Net New Impervious (NNI)
 - Replaced impervious surface (RIS)

2. Site Data and Stormwater Quality Design Issues

- Provide any additional information that may be pertinent to the project (e.g., Receiving Water, TMDLs, Drinking Water Reservoirs and/or Recharge Facilities, 303(d) water bodies, 401 certifications, ASBS).

3. Construction Site BMPs

- Briefly describe the Construction Site BMP strategy and include any pertinent details used for the implementation of Construction Site BMPs (e.g., specific project conditions, construction operations) and monitoring.
- Identify project risk level if project is subject to the CGP.
- Provide estimate information (see Section 6.4.4)
- Document the coordination effort to get concurrence from Construction regarding the Construction Site BMP strategy and associated quantities (provide names of staff and date of concurrence; required at PS&E only.)

Required Attachments¹

- Vicinity Map
- Evaluation Documentation Form
- Risk Level Determination Documentation (if applicable).
- SWDR Attachment for SMARTS Input (required at PS&E only if CGP is applicable) Construction BMP Estimate (for internal Caltrans use only) (at PS&E only)

¹ Additional attachments may be required as applicable or directed by the District/Regional Design Storm Water Coordinator (e.g., BMP line item estimate, SW, DPP, and CS Checklists).



Dist-County-Route: _____
 Post Mile Limits: _____
 Type of Work: _____
 Project ID (EA): _____
 Program Identification: _____
 Phase: PID PA/ED PS&E

Regional Water Quality Control Board(s): _____

Total Disturbed Soil Area: _____ PCTA: _____

Alternative Compliance (acres): _____ ATA 2 (50% Rule)? Yes No

Estimated Const. Start Date: _____ Estimated Const. Completion Date: _____

Risk Level: RL 1 RL 2 RL 3 WPCP Other: _____

Is MWELO applicable? Yes No

Is the Project within a TMDL watershed? Yes No

TMDL Compliance Units (acres): _____

Notification of ADL reuse (if yes, provide date): Yes Date: _____ No

This Report has been prepared under the direction of the following Licensed Person. The Licensed Person attests to the technical information contained herein and the date upon which recommendations, conclusions, and decisions are based. Professional Engineer or Landscape Architect stamp required at PS&E only.

 [Name], Registered Project Engineer/Landscape Architect Date

I have reviewed the stormwater quality design issues and find this report to be complete, current and accurate:

 [Name], Project Manager Date

 [Name], Designated Maintenance Representative Date

 [Name], Designated Landscape Architect Representative Date

[Stamp Required at PS&E only] _____
 [Name], District/Regional Design SW Coordinator or Designee Date

STORMWATER DATA INFORMATION

1. Project Description

- Clearly describe the type of project and major engineering features.
- Describe how the following values were calculated:
 - Total disturbed soil area (DSA)
 - New impervious surface (NIS)
 - Net New Impervious (NNI)
 - Replaced impervious surface (RIS)
 - PCTA
 - Determine if NNI is greater than 50% of the post project impervious area
 - Determine if existing Treatment BMPs are to be removed or modified as part of the project
- Document if Treatment BMPs are required or being incorporated to address TMDLs.

2. Site Data and Stormwater Quality Design Issues

Complete this section for all Projects. Project Engineer (PE) should confer with District/Regional Design Stormwater Coordinator, Landscape Architecture, Maintenance, Hydraulics, Construction and Environmental Unit to assist in defining design issues.

- Use source documents identified on Checklist SW-1 to briefly discuss applicable items listed on Checklists SW-2 and SW-3.
- Other information.

3. Construction Site BMPs to be used on Project

Complete this section for all Projects.

- Refer to Section 6.4.4 for typical Construction Site BMP information to be documented in this section.
- Identify project risk level, or summarize why project is exempt from Construction General Permit requirements.
- Checklist CS-1, Parts 1 – 6 can be used to provide general guidance for consideration of Construction Site BMPs to be used for the project.
- Briefly describe the Construction Site BMP strategy and include any pertinent details used for the implementation of Construction Site BMPs (e.g., specific project conditions, construction operations).
- Identify and describe as applicable:
 - Dewatering needs and requirements. Will a separate dewatering permit be needed?
 - Temporary creek or clear water diversion placement and design.
 - Active treatment systems (ATS) for stormwater or non-stormwater.
- Provide estimate information (see Section 6.4.4)

- Document the coordination effort to get concurrence from Construction regarding the Construction Site BMP strategy and estimate (provide names of staff and date of concurrence; required at PS&E only; recommended at all phases).

4. Maintenance BMPs

Complete this section or state not applicable. Coordinate Maintenance BMP efforts with the District Maintenance Staff to determine if Maintenance BMPs are needed.

- A typical Maintenance BMP related to stormwater quality that should be considered is drainage inlet stenciling. If used, briefly describe locations where drain inlet stenciling is required and include any specific stencil types other than Caltrans standard.
- Describe features to assist with maintaining BMPs; these may include maintenance vehicle pullouts, access gates and roads, and maintenance worker safety features. Briefly describe type and locations.

5. Other Water Quality Requirements and Agreements

Complete this section or state not applicable as directed by the District/Regional National Pollutant Discharge Elimination System (NPDES) Coordinator.

- Summarize any key negotiated understandings or agreements with RWQCB and other permitting agencies pertaining to this project.
- Document any specific meeting dates and contact names that reference the negotiated understandings and/or agreements.
- Identify any special requirements or conditions (e.g., inspections, monitoring, or reporting) from the PLACs related to stormwater and water quality, if available.

6. Permanent BMPs

Permanent BMPs are strategies and measures to minimize and avoid water quality impacts in the post construction condition. Permanent BMPs include Design Pollution Prevention and Treatment BMP strategies.

Rapid Stability Assessment

Complete this section if a Rapid Stability Assessment (RSA) is required.

- Document the number of crossings requiring an RSA and list any crossings that required a higher level analyses (Level 1-3).
- Describe any additional work proposed for the project due to the higher level analysis.

Design Pollution Prevention (DPP) BMP Strategy

Complete this section if DPP BMPs are proposed for the Project. Implementation of DPP BMPs is required for all projects; however, if the PE determines that the DPP BMP strategy does not necessitate a detailed discussion, state not applicable.

- Refer to Section 6.4.7.2 for typical DPP BMP information to be documented in this section.

- Refer to Checklist DPP-1, Part 1 for general determination of whether DPP BMPs should be considered for the project.
- Checklist DPP-1, Parts 2 - 5 can be used to provide general guidance for consideration of DPP BMPs to be used for the project.
- Describe DPP BMP strategy to avoid or minimize permanent water quality impacts.
- Describe DPP BMPs that are being used for TMDL CUs (stabilized areas only) and document area stabilized in acres. Other DPP BMPs that are infiltrating stormwater and being used for post construction treatment, Alternative Compliance, or CUs will be documented under the Treatment BMP Strategy section below.

Treatment BMP Strategy

Complete this section to document Treatment BMPs and credits; otherwise, state not applicable.

- Refer to Section 6.4.7.3 for typical Treatment BMP information to be documented in this section.
- Summarize the findings from Checklist T-1, Part 1.
- Summarize pertinent Feasibility and Design Elements responses to Checklist T-1, Parts 2-11 in a short narrative. **Only discuss Treatment BMP types considered for the project.**
- Provide a list of all Treatment BMPs being incorporated into the project. (see Table E-2)
- Describe how Alternative Compliance is being applied to the project or how the Post Construction Treatment Balance is being documented.
- Discuss any pertinent information related to eligible CU crediting generated by excess post construction treatment (excluding stabilized areas that do not consider taking infiltration credits), including any coordination efforts.
- At PS&E provide a cost for each Treatment BMP that is being used for post construction treatment, Alternative Compliance, or TMDL CUs (including stabilized areas). These costs are documented in the SWDR Summary Spreadsheets and/or Portal (Required at PS&E). These costs are for internal Caltrans use only.
- At PID and PA/ED based on the estimating method used (see F.3.1) provide a Treatment BMP estimate for Treatment BMPs that are being used for post construction treatment, Alternative Compliance, or TMDL CUs (including stabilized areas). Any costs provided are for Caltrans internal use only.

Complete the following table if treatment is required for the project.

Table E 1. Overall Project Treatment Summary Table ¹	
	PCTA (ac) ² A
Total Area to be Treated	Treated Impervious Area (CT RW) (ac) B
	Treated Impervious Area (Outside CT RW) (ac) ³ C
	PCTA Balance (ac) ⁴ D = (B+C) - A

- 1 This table is provided as an example. The table may be edited, altered, or removed as applicable or as directed by the District/Regional Design Stormwater Coordinator.
- 2 Provide treatment for ATA 1 even if NIS is less than 1 acre.
- 3 Requires Regional Board approval. Coordinate with District/Regional NPDES Coordinator.
- 4 If less than 0, additional treatment must be identified.

Required Attachments (see 6.4.8)

- Vicinity Map (see 6.4.8.1)
- Evaluation Documentation Form (EDF) (see E-10)
- Risk Level Determination Documentation (if applicable) (see 6.4.4.2)
- RUSLE2 Summary Sheet, as applicable (required at PS&E only)
- SWDR Attachment for SMARTS Input (required at PS&E only if CGP is applicable) (see E-11)
Construction BMP Estimate (for internal Caltrans use only) (at PS&E only) (see 6.4.4)

Supplemental Attachments

Note: Supplemental Attachments are to be supplied during the SWDR approval process when requested; where noted, some of these items may only be requested on a project-specific basis.

- Checklist SW-1, Site Data Sources (see E-14, 6.4.3.1)
- Checklist T-1, Part 1 (Treatment BMPs), if applicable (see E-15)
- Estimate Support Information for Construction Site, DPP, and/or Treatment BMPs, electronic copies accepted (Costs are for Caltrans internal use only)
- Calculations and supporting information for sizing Treatment BMPs or DPP BMPs or claiming post construction treatment or CUs (contact the District/Regional NPDES Coordinator for expected method of documentation), if applicable
- SWDR Summary Spreadsheets
- Plans showing BMP deployment (e.g., Layout Sheets, Drainage Sheets, Water Pollution Control Sheets) (if requested by District/Regional Design Stormwater Coordinator), if applicable
- Method Demonstration Form (if prepared) (see 6.4.7.4)
- Documentation of Rapid Stability Assessment findings, including any higher level evaluation, if required (see 1.4.2.1)
- MWELo Excel Worksheet, if applicable (see 6.4.7.5)
- Checklist SW-2, Stormwater Quality Issues Summary (see 6.4.3.1)
- Checklist SW-3, Measures for Avoiding or Reducing Potential Stormwater Impacts (see 6.4.3.1)
- Checklist DPP-1, Parts 1–5 (Design Pollution Prevention BMPs) (see Appendix A)
- Checklist T-1, Part 2–11 (Treatment BMPs) (see Appendix B)
- Construction Site BMP Consideration Form (see Appendix C)
- Checklist CS-1, Parts 1–6 (Construction Site BMPs) (see Appendix C)

DATE: _____

Project ID (EA): _____

No.	Criteria	Yes ✓	No ✓	Supplemental Information for Evaluation
1.	Begin Project evaluation regarding requirement for implementation of Treatment BMPs	✓		See Figure 4-1, Project Evaluation Process for Consideration of Treatment BMPs. Continue to 2.
2.	Is the scope of the Project to install Treatment BMPs (e.g., Alternative Compliance or TMDL Compliance Units)?			If Yes , go to 8. If No , continue to 3.
3.	Is there a direct or indirect discharge to surface waters?			If Yes , continue to 4. If No , go to 9.
4.	As defined in the WQAR or ED, does the project:			If Yes to any , contact the District/Regional Design Stormwater Coordinator or District/Regional NPDES Coordinator to discuss the Department's obligations, go to 8 or 5. _____ (Dist./Reg. Coordinator initials) If No to all, continue to 5.
	a. discharge to Areas of Special Biological Significance (ASBS), or			
	b. discharge to a TMDL watershed where Caltrans is named stakeholder, or			
	c. have other pollution control requirements for surface waters within the project limits?			
5.	Are any existing Treatment BMPs partially or completely removed? (ATA Condition 1, Section 4.4.1)			If Yes , go to 8 AND continue to 6. If No , continue to 6.
6.	Is this a Routine Maintenance Project?			If Yes , go to 9. If No , continue to 7.
7.	Does the project result in an increase of <u>one acre or more</u> of new impervious surface (NIS)?			If Yes , go to 8. If No , go to 9.
8.	Project is required to implement Treatment BMPs.	Complete Checklist T-1, Part 1.		
9.	Project is not required to implement Treatment BMPs. _____ (Dist./Reg. Design SW Coord. Initials) _____ (Project Engineer Initials) _____ (Date)	Document for Project Files by completing this form and attaching it to the SWDR.		

DESIGN INFORMATION FOR CONSTRUCTION

The following information is based on the PS&E design plans and specifications. If contract amendments or change orders are made after the design is complete, then the information should be updated by construction, as appropriate.

Project ID (EA): _____

Enter the following data into the CGP SMARTS Notice of Intent-Site Information page.

1. **Total site size** (acres); for project area use Caltrans RW x post mile limits (begin-end) on plan sheets.

Total site size _____ acres

2. Enter **latitude and longitude** in decimal degrees to 5 significant figures. Use a location from the center of the project. This information can be obtained from Survey information, GPS units, Google earth, CT Earth, or other mapping software.

Latitude: _____

Longitude: _____

3. **Total Area to be Disturbed** (total Disturbed Soil Area (DSA)): This information is already calculated and can be taken from SWDR Section 1. Describe in acres.

DSA _____ acres

4. **Imperviousness before Construction (percentage)** - This is calculated as the total impervious area of the project area divided by the total project area (see total site size), multiplied by 100. The impervious area is all paved areas or hard surfaces within the project limits.

Impervious area before construction % _____

5. **Percent of total disturbed (percentage)**; This should be calculated by dividing the total disturbed soil area by the total project area and multiply by 100.

Percent of Total disturbed area % _____

6. **Imperviousness after Construction (percentage)**, This should be calculated by adding all impervious area paved and hard surfaces based on the final design within project limits from above and dividing by the total project area from above multiply by 100.

Impervious area after construction % _____

7. **Mile Post Marker**, enter the approximate post mile at the center of the project or take the average of the "begin" and "end" post mile markers from the title sheet.

Mile post Marker _____



8. **Is the construction site part of a larger common plan of development?** Yes or No; in most cases mark No for Caltrans projects, as this is intended for developers (in accordance with the EPA definitions referenced by the CGP in 40 CFR title 22). This clarification is based on direction from the State Board, see Appendix G for the definition of common plan of development. Coordinate with the District/Regional Design Stormwater Coordinator to determine if there is a special case project where the common plan of development applies. No

9. **Name of development.** Mark “Not Applicable (N/A)” in most cases.

Name of plan or development: N/A

10. **Estimated Construction Commencement Date**, mm/dd/yyyy. The PE provides the estimated construction start date from the cover of the SWDR. The actual construction start date should be used to input into SMARTS. After the contract is awarded, the RE will use an updated start date (if different) when entering in SMARTS. The RE needs to be aware of the original date provided by Design, as this date was used to calculate the design information including the Risk Level Determination. If the actual start date is different, construction should coordinate with the PE to determine if the Risk Level has changed.

Estimated Construction Commencement Date, mm/dd/yyyy.

11. **Estimated Complete Grading Date/Complete Project Date;** The PE provides the estimated construction completion date from the cover of the SWDR to be used for both of these inputs. After the contract is awarded, the RE will use an updated completion date (if different) when entering in SMARTS. The RE needs to be aware of the original completion date provided by Design, as this date was used to calculate the design information including the Risk Level Determination. If the completion date is different, construction should coordinate with the PE to determine if the Risk Level has changed.

Estimated Complete Grading Date/Complete Project: mm/dd/yyyy. Use the same date for both inputs, unless instructed otherwise.

12. **Does the Stormwater from the construction site discharge directly or indirectly into waters of the United States.**

Indirect discharge (Y/N) - If yes, list name(s) of receiving water(s) _____

Direct discharge (Y/N) - If yes, list name(s) of receiving water(s) _____



13. **Risk Level**; the combined project risk level is calculated using the sediment risk factor and the water body risk factor to give one overall project risk level. Use the Caltrans risk level determination guidance, (see the Stormwater design web page). Attach all risk calculations.

R factor value _____

K factor value _____

LS factor value _____

Receiving water risk comes from the state water resources control board mapping of water bodies for 303-d listing or TMDLs for sediment or water body with the beneficial use of cold and spawn and migratory. The input will either be high=yes and low=no;

Receiving water risk _____, (yes or no)

The dates used for determining the project risk level and other design elements of the project required for CGP compliance are dependent on having the same sediment risk factor. This is a critical element for compliance, as modifying the estimated construction dates may cause the sediment risk factor to change and ultimately modify the overall project risk factor. This could impact the projects CGP compliance requirements and the assumptions used for the design documents and engineers estimate.

14. **Post Construction**: The PE provides project information related to Municipal Separate Storm Sewer System (MS4) areas.

Is the project located within a permitted Phase I or Phase II MS4 area? This will usually be answered Yes for all projects.

Does the Phase I or Phase II MS4 have an approved Stormwater Management Plan (SWMP) that includes post-construction requirements? This will usually be answered Yes for all projects.

Contact the District/Regional NPDES Coordinator with any questions.

15. Provide electronic copy of plan sheets in .pdf format that can be loaded to SMARTS, burn a CD for the RE to use for the project. The Title sheet can be used as the site map.

16. Methodology for obtaining the CGP NOT decided by the PDT, see SWDR Section 6 text for methodology text and computational proof as appropriate, circle one. See SWRCB bulletin for details: http://www.waterboards.ca.gov/water_issues/programs/stormwater/docs/bulletin_2013_1.pdf

- a. 70% final cover method: Attach photo documentation _____
- b. RUSLE II: Attach computational proof and photo documentation _____
- c. Other custom method if coordinated with local regional board, attach photo documentation or other proof as necessary.



Checklist SW-1, Site Data Sources		
Prepared by: _____	Date: _____	District-Co-Route: _____
PM: _____	Project ID (or EA): _____	RWQCB: _____

Information for the following data categories should be obtained, reviewed and referenced as necessary throughout the project planning phase. Collect available project reports and any available documents pertaining to the category and list them and reference your data source. For specific examples of documents within these categories, refer to Section 6.4.3.2. Example categories have been listed below; add additional categories, as needed. Summarize pertinent information in Section 2 of the SWDR.

DATA CATEGORY/SOURCES	Date
Water Quality	
•	
•	
•	
Geotechnical	
• <i>Example: Geotechnical Design Report (Project Report)</i>	
•	
•	
Topographic	
•	
•	
•	
Hydraulic	
• <i>Example: Hydrology/Hydraulic/Drainage Report (Project Report)</i>	
•	
•	
Climatic	
•	
•	
•	
Other Data Categories	
• <i>Example: Materials Report (Project Report)</i>	
•	
•	



Treatment BMPs Checklist T-1, Part 1		
Prepared by: _____	Date: _____	District-Co-Route: _____
PM: _____	Project ID (or EA): _____	RWQCB: _____

Consideration of Treatment BMPs

This checklist is used for projects that require the consideration of Approved Treatment BMPs, as determined from the process described in Section 4 (Treatment Consideration) and the Evaluation Documentation Form (EDF). This checklist will be used to determine which Treatment BMPs should be considered for each BMP contributing drainage area within the project. Supplemental data will be needed to verify siting and design applicability for final incorporation into a project.

Complete this checklist for each phase of the project. This will help to determine if any changes to the BMP strategy are necessary, based on site specific information gathered during later phases. Use the responses to the questions as the basis of developing the narrative in Section 6 of the Stormwater Data Report to document that Treatment BMPs have been appropriately considered and/or incorporated.

Before evaluating an area for treatment capabilities or to incorporate a Treatment BMP, calculate the numeric sizing requirement for each contributing drainage area (WQV from the 85th percentile 24-hour storm event or WQF rate). Soil and geometric information for the project area will be necessary to use this Checklist.

Identify the overall project PCTA

Refer to Section 4.4 Treatment Areas for more information on defining these areas.

$PCTA = NNI + RIS + ATA (1 \text{ Impervious}) + ATA (2)$

NNI = Net New Impervious Area

RIS = Replaced Impervious Surface

ATA (1 Impervious) = Additional Treatment Area required for existing Treatment BMPs that were removed or modified as part of the project

ATA (2) = Additional Treatment Area required when NNI is 50 percent or greater than total project impervious

What is the PCTA for the project? _____ Acres (A in Table E-1)

The PCTA is the impervious area required to be treated by the project. The PE is to incorporate BMPs until the summation of the treated impervious area of all the BMPs is equivalent to the PCTA for the Project.

Once this area and any ATA 1 (Pervious) has been treated, the project is in compliance with the post construction treatment requirement.

Total Maximum Daily Load (TMDL) Retrofit Projects

If the project is installing Treatment BMPs to only address TMDL requirements, then there is no required PCTA. The Treatment BMPs for a TMDL retrofit project should be designed to treat the impervious and pervious contributing drainage areas, as they are both eligible for compliance unit (CU) credits.



Overall Project Evaluation

Answer all questions, unless otherwise directed.

A. Overall Project Consideration

1. Is the project in a watershed with prescriptive Treatment BMP requirements in an adopted TMDL implementation plan or are there any other requirements for project area (e.g., District, Regional Board, Lawsuit)? Yes No

If Yes, consult the District/Regional Design Stormwater Coordinator or District/Regional NPDES Coordinator to determine if there are written agreements related to specific Treatment BMPs. In this case, determine if the rest of this checklist needs to be followed to address other post construction requirements. If not, document BMP(s) in the Individual Treatment BMP Summary Table, provide information on the basis of the BMP requirement and any regulatory coordination in the SWDR narrative, and complete Table E-2. Otherwise, continue.

If No, continue.

2. Does the receiving water have a TMDL for litter/trash, or is there a region specific requirement related to trash? Yes No

If Yes, first evaluate BMPs that can treat other pollutants and are considered to be full capture devices (GSRDs or other) for litter/trash. If other BMPs cannot be sited, consult with the District/Regional Design Stormwater Coordinator or District/Regional NPDES Coordinator to determine if standalone full capture devices (GSRDs or other) are required to be incorporated. If standalone devices are required and no other Treatment BMPs are being considered, go to question 6 of “Individual BMP Evaluation”.

If No, continue.

3. Is the project located in an area that uses traction sand more than twice a year? Yes No

If Yes, first consider BMPs that can treat other pollutants and can capture traction sand. If other BMPs cannot be sited, consult the District/Regional Design Stormwater Coordinator to determine if standalone traction sand trap devices should be incorporated.

If standalone devices are required and no other Treatment BMPs are being considered, go to question 6 of “Individual BMP Evaluation”. Otherwise, continue with this checklist to identify Treatment BMPs that provide traction sand and other pollutant removal, or to design Treatment BMPs in series.

If No, continue.



B. Dual Purpose Facilities

Does the project have (or propose to include) any dual purpose facilities that could meet treatment requirements (e.g., Dry Weather Flow Diversion, flood control basins, etc.)? Yes No

If Yes and 100 percent of the PCTA and ATA 1 (Pervious) will be treated by the dual purpose facility, go to question 6 of “Individual BMP Evaluation”.

If Yes, but 100 percent of the PCTA and ATA 1 (Pervious) has not been addressed, continue.

If No, continue.

C. Evaluate overall project area for infiltration opportunities using existing and proposed roadside surfaces (DPP Infiltration Areas). Assure the DPP Infiltration Area is stabilized to handle highway drainage design flows, for both sheet and concentrated flows (See HDM Section 800).

Document DPP Infiltration Areas on the “Individual Treatment BMP Summary Table” located at the end of this checklist.

1. Based on site conditions, do the DPP Infiltration Areas infiltrate 100 percent of the WQV generated by the PCTA and ATA 1 (Pervious) for the project? Yes No

Yes, go to question 6 of “Individual BMP Evaluation”.

If No, account for area infiltrated and continue.

2. Can infiltration for these areas be increased by using soil amendments or other means? Yes No

If Yes, and 100 percent of the WQV generated by the PCTA and ATA 1 (Pervious) is infiltrated, go to question 6 of “Individual BMP Evaluation”.

If Yes, but 100 percent of the WQV generated by the PCTA and ATA 1 (Pervious) is not infiltrated, continue with this checklist to identify Treatment BMPs that will treat the remaining PCTA and ATA 1 (Pervious).

If No, continue.

Individual BMP Evaluation

Answer the following questions for each Treatment BMP location being considered. The following process must be followed until the PCTA and ATA 1 (Pervious) or desired treatment area (Alternative Compliance or TMDL CUs) has been achieved; for TMDL CUs, consider both impervious and pervious contributing drainage areas. Use the Individual Treatment BMP Summary Table at the end of the checklist to summarize the selected BMP(s) based on the findings of the following questions for each BMP contributing drainage area.

1. Infiltration Devices (Infiltration Basin, Trench, or other device)

- a. Can 100 percent of the BMP contributing drainage area WQV (or remaining WQV, if in series with a DPP Infiltration Area or other BMP) be infiltrated? Yes No

If Yes, go to question 6.

If No, continue.

2. LID flow through Devices (Biofiltration Strips, Swales, & Bioretention)

- a. Is this a TMDL retrofit project or is the project within a TMDL watershed or 303(d) impaired receiving water body area? Yes No

If Yes, when designing the TBMP device, determine the percent WQV infiltrated from both the impervious and pervious BMP contributing drainage areas.

Consider using existing or amended soils:

- i. If infiltration is >50 percent, continue to b.
- ii. If infiltration is ≤50 percent, go to question 3.

If No, continue to b.

- b. Can Biofiltration and Bioretention devices be designed to: Yes No

- i. Treat 100 percent of the WQF/WQV (or remainder, if in series with a DPP Infiltration Area or other BMP) from the BMP contributing drainage area, and
- ii. Meet the siting and design criteria of the Caltrans TBMP design guidance.

If Yes, continue to c.

If No, go to question 3.

- c. Biofiltration and Bioretention devices are considered to be an effective method of treatment, go to question 6.



3. Earthen type BMPs (Detention Devices, Media Filters, or other devices)

- a. Is this a TMDL retrofit project or is the project within a TMDL watershed or 303(d) impaired receiving water body area? Yes No

If Yes, when designing the earthen type BMP, determine the percent WQV infiltrated from both the impervious and pervious BMP contributing drainage area. Consider using existing or amended soils:

- i. If infiltration is >50 percent, continue to b.
- ii. If infiltration is ≤50 percent, go to question 4.

If No, continue to b.

- b. Can earthen type BMPs (standalone or in series with other approved Treatment BMPs) be designed to: Yes No

- iii. Treat 100 percent of the WQV (or remainder, if in series with a DPP Infiltration Area or other BMP) from the BMP contributing drainage area, and
- iv. Meet the criteria of the Caltrans design guidance for the treatment device being considered.

If Yes, continue to c.

If No, go to question 4.

- c. Earthen type BMPs are considered to be an effective method of treatment, go to question 6.

4. Targeted Design Constituent (TDC)

This approach will compare the effectiveness of individual BMPs and allow the PE to use judgment when evaluating BMP feasibility (site constraints, safety, maintenance requirements, life-cycle costs, etc.).

- a. Does the project discharge to a 303(d) impaired receiving water or a receiving water in a TMDL watershed where Caltrans is a named stakeholder? Yes No

If Yes, is the identified pollutant(s) considered to be a TDC (check all that apply below)? Continue to b. Yes No

- | | |
|-------------------------------------|---|
| <input type="checkbox"/> sediments | <input type="checkbox"/> copper (dissolved or total) |
| <input type="checkbox"/> phosphorus | <input type="checkbox"/> lead (dissolved or total) |
| <input type="checkbox"/> nitrogen | <input type="checkbox"/> zinc (dissolved or total) |
| | <input type="checkbox"/> general metals (dissolved or total) ¹ |

If No or if no TDC is identified, use Matrix A to select BMPs and go to question 5.

- b. Treating Only Sediment. Is sediment a TDC? Yes No

If Yes, use Matrix A to select BMPs and go to question 5.

If No, continue to c.

- c. Treating Only Metals. Are copper, lead, zinc, or general metals listed TDCs? Yes No

If Yes, use Matrix B to select BMPs, and go to question 5.

If No, continue to d.

- d. Treating Only Nutrients. Are nitrogen and/or phosphorus listed TDCs? Yes No

If Yes, use Matrix C to select BMPs, and go to question 5.

If No, continue e.

- e. Treating both Metals and Nutrients. Is copper, lead, zinc, or general metals AND nitrogen or phosphorous a TDC? Yes No

If yes, use Matrix D to select BMPs, and go to question 5.

If No, continue.

¹ General metals is a designation used by Regional Water Boards when specific metals have not yet been identified as causing the impairment.

BMP Selection Matrix A: General Purpose Pollutant Removal			
<p>Consider BMPs (or combinations of) to treat the contributing drainage area WQV with BMPs listed in this table. First evaluate Tier 1 BMPs, followed by Tier 2 BMPs when Tier 1 BMPs are not feasible. Within each Tier, BMP selection will be determined by the site-specific determination of feasibility, which includes life cycle costs. BMPs are chosen based on the infiltration category determined for BMP contributing drainage area. All BMPs shown are approved and may be used.</p>			
	BMP ranking for infiltration category:		
	Infiltration < 20%	Infiltration 20% - 50%	Infiltration > 50%
Tier 1	Bioretention (all) Strip: HRT > 5 min Austin filter (concrete) Austin filter (earthen) Delaware filter OGFC	Austin filter (earthen) Detention (unlined) Infiltration basins Infiltration trenches Biofiltration Strip Bioretention (unlined)	Austin filter (earthen) Detention (unlined) Infiltration basins Infiltration trenches Biofiltration Strip Biofiltration Swale Bioretention (unlined)
Tier 2	Strip: HRT < 5 min Biofiltration Swale Detention (unlined)	Austin filter (concrete) Delaware filter Biofiltration Swale Bioretention (lined) OGFC	Austin filter (concrete) Delaware filter Bioretention (lined) OGFC
<p>All BMPs shown are considered effective. The PE should use professional judgment when selecting BMPs based on overall site design and feasibility.</p>			
BMP Selection Matrix B: Any metal is the TDC, but not nitrogen or phosphorous			
<p>Consider BMPs (or combinations of) to treat the contributing drainage area WQV with BMPs listed in this table. First evaluate Tier 1 BMPs, followed by Tier 2 BMPs when Tier 1 BMPs are not feasible. Within each Tier, BMP selection will be determined by the site-specific determination of feasibility, which includes life cycle costs. BMPs are chosen based on the infiltration category determined for BMP contributing drainage area. All BMPs shown are approved and may be used.</p>			
	BMP ranking for infiltration category:		
	Infiltration < 20%	Infiltration 20% - 50%	Infiltration > 50%
Tier 1	Austin filter (earthen) Austin filter (concrete) Bioretention (all) Delaware filter	Austin filter (earthen) Bioretention (unlined) Detention (unlined) Infiltration basins Infiltration trenches	Austin filter (earthen) Bioretention (unlined) Detention (unlined) Infiltration basins Infiltration trenches Biofiltration Strip Biofiltration Swale
Tier 2	Strip: HRT > 5 min Strip: HRT < 5 min Biofiltration Swale Detention (unlined)	Austin filter (concrete) Bioretention (lined) Delaware filter Biofiltration Strip Biofiltration Swale OGFC	Austin filter (concrete) Bioretention (lined) Delaware filter OGFC
<p>All BMPs shown are considered effective. The PE should use professional judgment when selecting BMPs based on overall site design and feasibility.</p>			



BMP Selection Matrix C: Phosphorous and / or nitrogen is the TDC, but no metals are the TDC			
Consider BMPs (or combinations of) to treat the contributing drainage area WQV with BMPs listed in this table. First evaluate Tier 1 BMPs, followed by Tier 2 BMPs when Tier 1 BMPs are not feasible. Within each Tier, BMP selection will be determined by the site-specific determination of feasibility, which includes life cycle costs. BMPs are chosen based on the infiltration category determined for BMP contributing drainage area. All BMPs shown are approved and may be used.			
	BMP ranking for infiltration category:		
	Infiltration < 20%	Infiltration 20% - 50%	Infiltration > 50%
Tier 1	Austin filter (earthen) Austin filter (concrete) Delaware filter* OGFC*	Austin filter (earthen) Detention (unlined) Infiltration basins Infiltration trenches	Austin filter (earthen) Detention (unlined) Infiltration basins Infiltration trenches Biofiltration Strip & Swale Bioretention (unlined)
Tier 2	Biofiltration Strip Biofiltration Swale Detention (unlined) Bioretention (all)	Austin filter (concrete) Delaware filter Biofiltration Strip Biofiltration Swale Bioretention (all) OGFC	Austin filter (concrete) Bioretention (lined) Delaware filter OGFC
All BMPs shown are considered effective. The PE should use professional judgment when selecting BMPs based on overall site design and feasibility.			
*Delaware and OGFC filters would be ranked in Tier 2 if the TDC is nitrogen only, as opposed to phosphorous only or both nitrogen and phosphorous.			
BMP Selection Matrix D: Any metal, plus phosphorous and / or nitrogen are the TDCs			
Consider BMPs (or combinations of) to treat the contributing drainage area WQV with BMPs listed in this table. First evaluate Tier 1 BMPs, followed by Tier 2 BMPs when Tier 1 BMPs are not feasible. Within each Tier, BMP selection will be determined by the site-specific determination of feasibility, which includes life cycle costs. BMPs are chosen based on the infiltration category determined for BMP contributing drainage area. All BMPs shown are approved and may be used.			
	BMP ranking for infiltration category:		
	Infiltration < 20%	Infiltration 20% - 50%	Infiltration > 50%
Tier 1	Austin filter (earthen) Austin filter (concrete) Delaware filter*	Austin filter (earthen) Detention (unlined) Infiltration basins Infiltration trenches	Austin filter (earthen) Detention (unlined) Infiltration basins Infiltration trenches Biofiltration Strip & Swale Bioretention (unlined)
Tier 2	Biofiltration Strip Biofiltration Swale Detention (unlined) Bioretention (all) OGFC	Austin filter (concrete) Delaware filter Biofiltration Strip Biofiltration Swale Bioretention (all) OGFC	Austin filter (concrete) Bioretention (lined) Delaware filter OGFC
All BMPs shown are considered effective. The PE should use professional judgment when selecting BMPs based on overall site design and feasibility.			
*In cases where earthen BMPs also infiltrate, Delaware filters are ranked in Tier 2 if the TDC is nitrogen only, but they are Tier 1 for phosphorous only or both nitrogen and phosphorous.			

5. Does the project discharge to a 303(d) receiving water that is listed for mercury or low dissolved oxygen? Yes No

If Yes, contact the District/Regional NPDES Coordinator to determine if standing water in a Delaware Media Filter or Wet Basin would be a risk to downstream water quality. Continue to question 6.

If No, continue to question 6.

6. Identify the Treatment BMPs being considered and complete the Individual Treatment BMP Summary Table and Overall Project Treatment Summary Table on the following pages. Refer to Appendix B of the PPDG and review the checklists identified below for every Treatment BMP under consideration. Complete

Document the basis of design in the SWDR narrative and complete Table E-2.

___ DPP Infiltration Areas: Checklist T-1, Part 11

___ Infiltration Devices: Checklist T-1, Part 2

___ Biofiltration Strips and Biofiltration Swales: Checklist T-1, Part 3

___ Detention Devices: Checklist T-1, Part 4

___ Traction Sand Traps: Checklist T-1, Part 5

___ Dry Weather Diversion: Checklist T-1, Part 6

___ GSRDs: Checklist T-1, Part 7

___ Media Filter [Austin Sand Filter and Delaware Filter]: Checklist T-1, Part 8

___ Bioretention

___ Open Graded Friction Course (OGFC)

Note:

Multi-Chamber Treatment Train (MCTT) is not listed here because Caltrans has found that other approved BMPs are equally effective and more sustainable due to lower life cycle costs.

Wet Basins are not listed here due to feasibility issues due to site feasibility and issues with long term operation and maintenance.

MCTT and Wet Basins may be considered or implemented upon the recommendation of the District/Regional Design Stormwater Coordinator.

7. Prepare cost estimate, including right-of-way, and identify any pertinent site specific determination of feasibility for selected Treatment BMPs and include in the SWDR for approval. Complete



Individual Treatment BMP Summary Table

List the selected BMPs based on the findings of this checklist and the treated areas associated with each BMP in Table E-2. For projects with multiple BMPs, add rows (if needed), or attach a separate sheet displaying the following information.

Complete

Each BMP must be tracked in Table E-2. Districts may use a modified table based upon their needs. See Section 6.6 for additional information.

Table E 2. Individual Treatment BMP Summary Table ¹						
BMP Identifier-Number	BMP Type	Treated Impervious Area (CT RW) (ac)	Treated Impervious Area (Outside CT RW) (ac)	Treated Pervious Area (CT RW) (ac)	Treated Pervious Area (Outside CT RW) (ac)	Treated WQV/WQF (%)
Total Area to be Treated (acre)		(B in Table E-1)	(C in Table E-1)			

¹ The treated areas identified in this table are a product of the BMP CDA and Treated WQV/WQF (%).



Checklist SW-2, Stormwater Quality Issues Summary

Prepared by: _____ Date: _____ District-Co-Route: _____

PM: _____ Project ID/EA: _____ RWQCB: _____

The following questions provide a guide to collecting critical information relevant to project stormwater quality issues. Consult other Caltrans functional units (Environmental, Landscape Architecture, Maintenance, etc.) and the District/Regional Design Stormwater Coordinator as necessary. Summarize pertinent responses in Section 2 of the SWDR; do not discuss items identified as not applicable.

- | | | |
|--|-----------------------------------|-----------------------------|
| 1. Determine the receiving waters for the project | <input type="checkbox"/> Complete | <input type="checkbox"/> NA |
| 2. For the project limits, list the 303(d) impaired receiving water bodies and their constituents of concern. | <input type="checkbox"/> Complete | <input type="checkbox"/> NA |
| 3. Determine if there are any municipal or domestic water supply reservoirs or groundwater percolation facilities within the project limits, as shown by DWP. | <input type="checkbox"/> Complete | <input type="checkbox"/> NA |
| 4. Determine the RWQCB special requirements, including TMDLs, effluent limits, etc. | <input type="checkbox"/> Complete | <input type="checkbox"/> NA |
| 5. Determine regulatory agencies seasonal construction and construction exclusion dates or restrictions required by federal, state, or local agencies. | <input type="checkbox"/> Complete | <input type="checkbox"/> NA |
| 6. Determine if a 401 certification will be required. | <input type="checkbox"/> Complete | <input type="checkbox"/> NA |
| 7. Identify rainy season. | <input type="checkbox"/> Complete | <input type="checkbox"/> NA |
| 8. If applicable, determine the general climate of the project area. Identify annual rainfall and rainfall intensity curves. | <input type="checkbox"/> Complete | <input type="checkbox"/> NA |
| 9. If considering Treatment BMPs, determine the soil classification, permeability, erodibility and depth to groundwater. | <input type="checkbox"/> Complete | <input type="checkbox"/> NA |
| 10. Determine contaminated soils within the project area. | <input type="checkbox"/> Complete | <input type="checkbox"/> NA |
| 11. Determine the total disturbed soil area of the project. | <input type="checkbox"/> Complete | <input type="checkbox"/> NA |
| 12. Describe the topography of the project site. | <input type="checkbox"/> Complete | <input type="checkbox"/> NA |
| 13. List any areas outside of the Caltrans right-of-way that will be included in the project (e.g., contractor's staging yard, work from barges, easements for staging). | <input type="checkbox"/> Complete | <input type="checkbox"/> NA |
| 14. Determine if additional right-of-way acquisition or easements and right-of-entry will be required for design, construction and maintenance of BMPs. If so, how much? | <input type="checkbox"/> Complete | <input type="checkbox"/> NA |
| 15. Determine the estimated unit costs for right-of-way should it be needed for Treatment BMPs, stabilized conveyance systems, lay-back slopes, or interception ditches. | <input type="checkbox"/> Complete | <input type="checkbox"/> NA |
| 16. Determine if project area has any slope stabilization concerns. | <input type="checkbox"/> Complete | <input type="checkbox"/> NA |
| 17. Describe the local land use within the project area and adjacent areas. | <input type="checkbox"/> Complete | <input type="checkbox"/> NA |
| 18. Evaluate the presence of dry weather flow. | <input type="checkbox"/> Complete | <input type="checkbox"/> NA |



Checklist SW-3, Measures for Avoiding or Reducing Potential Stormwater Impacts

Prepared by: _____ Date: _____ District-Co-Route: _____

PM: _____ Project ID/EA: _____ RWQCB: _____

The PE should confer with other functional units, such as Landscape Architecture, Hydraulics, Environmental, Materials, Construction and Maintenance, as needed to assess these issues. Summarize pertinent responses in Section 2 of the SWDR; do not discuss items identified as not applicable.

Options for avoiding or reducing potential impacts during project planning include the following:

1. Can the project be relocated or realigned to avoid/reduce impacts to receiving waters or to increase the preservation of critical (or problematic) areas such as floodplains, steep slopes, wetlands, and areas with erosive or unstable soil conditions? Yes No NA

2. Can structures and bridges be designed or located to reduce work in live streams and minimize construction impacts? Yes No NA

3. Can any of the following methods be utilized to minimize erosion from slopes:
 - a. Disturbing existing slopes only when necessary? Yes No NA
 - b. Minimizing cut and fill areas to reduce slope lengths? Yes No NA
 - c. Incorporating retaining walls to reduce steepness of slopes or to shorten slopes? Yes No NA
 - d. Acquiring right-of-way easements (such as grading easements) to reduce steepness of slopes? Yes No NA
 - e. Avoiding soils or formations that will be particularly difficult to re-stabilize? Yes No NA
 - f. Providing cut and fill slopes flat enough to allow re-vegetation and limit erosion to pre-construction rates? Yes No NA
 - g. Providing benches or terraces on high cut and fill slopes to reduce concentration of flows? Yes No NA
 - h. Rounding and shaping slopes to reduce concentrated flow? Yes No NA
 - i. Collecting concentrated flows in stabilized drains and channels? Yes No NA

4. Does the project design allow for the ease of maintaining all BMPs? Yes No

5. Can the project be scheduled or phased to minimize soil-disturbing work during the rainy season? Yes No

6. Can permanent stormwater pollution controls such as paved slopes, vegetated slopes, basins, and conveyance systems be installed early in the construction process to provide additional protection and to possibly utilize them in addressing construction stormwater impacts? Yes No NA



APPENDIX F: COST ESTIMATES



THIS PAGE INTENTIONALLY LEFT BLANK.

F.1 Introduction

The objective of this appendix is to provide general guidance on incorporating the cost of stormwater BMPs into the project delivery process; however, it is understood that local district procedures for cost estimating may vary. The cost estimator needs to research, compare, and, above all, use their professional judgment to prepare a quality cost estimate.

F.1.1 Policy and Guidance

The Caltrans Division of Design has developed the following website to assist in the development of cost estimates:

<http://www.dot.ca.gov/hq/oppd/costest/costest.htm>

This website includes links to Chapter 20 Project Development Cost Estimates of the *Project Development Procedures Manual* and *Caltrans Cost Estimating Guidelines*. Chapter 20 describes the purpose and policies behind cost estimates and provides guidance for planning and feasibility for Project Initiation Cost Estimates (PID), Project Report Cost Estimates (PA/ED), and Project Design Cost Estimates (PS&E).

In addition to Chapter 20, this website includes other useful cost estimating information on project cost escalation, contingency and supplemental work, and cost estimating templates for the planning and design phases of the project. These templates may be used to track estimates relating to costs for incorporating stormwater BMPs.

F.1.2 Construction Duration

Particular attention to estimating is required when a project is anticipated to extend beyond a single construction season. If the project cannot be finished before the end of the construction season and the project needs to be suspended, contractors will increase their bid prices to cover their overhead during the winter (i.e., “rainy” or “wet” season) and repair any damage that may occur. Even if contractors reasonably expect to finish before the winter, they may protect themselves to allow for an early winter. This can especially be true if construction involves work on items that may be affected by winter weather (e.g., drainage channels, earthwork, slope stabilization), or that requires deployment of additional Construction Site BMPs. Therefore, if a construction project is anticipated to extend over one or more rainy seasons, adjust the estimated cost for Construction Site BMPs per Section F.3.3.

F.2 Standard Specifications, Contract Plans, and Special Provisions

The Standard Specifications, along with the Contract Plans and Special Provisions for a specific project, prescribe the details for construction and completion of work. Coordination is required for consistency with the District Cost Estimate, the Standard Specifications, Contract Plans, and Special Provisions.

F.3 Estimating Methods

Cost estimating procedures may vary for each district, though there are two general estimating methods that may be used to establish prices for stormwater BMPs. Table F-1 lists the methods that

are generally available during the different project delivery processes. The estimating methods are described in the following sections.

Table F 1. Estimating Methods Available During the Project Development Processes		
Project Process	Estimating Method	Documentation
PID	Project Initiation Cost Estimate ¹ (Section F.3.1)	Stormwater Data Report (SWDR) / Project Planning Cost Estimate (PPCE)
PA/ED	Project Initiation Cost Estimate and Project Design Cost Estimate (Section F.3.2)	Updated PPCE
PS&E	Project Design Cost Estimate	Preliminary Engineer's Cost Estimate (PECE)

¹If Design Pollution Prevention and Treatment BMPs are not included in costs of other work (Erosion Control, Drainage, etc.), then Previous Bid Prices Method should be used to develop these BMP estimates.

The PE must provide estimates for the following stormwater related items:

- Construction Site BMPs
- Design Pollution Prevention BMPs
- Treatment BMPs
- Right-of-way Acquisition (see District Right-of-Way)

Water Pollution Control programmatic and supplemental costs must be estimated for all projects at each phase. Guidance to estimate these costs are provided in Section F.3.

F.3.1 Project Initiation Cost Estimate Method

This method can be used during the PID and PA/ED process to develop the PPCE.

Lane mile costs for Design Pollution Prevention and Treatment BMPs can be used at PID. For new construction or major reconstruction projects, include an additional \$100,000 to \$250,000 per lane mile to cover costs associated with incorporating DPP and Treatment BMPs for PID. The lower end of this range would apply to projects that are in rural areas, with adequate space to install earthen type Treatment BMPs. The higher end of this range would apply to projects in more urbanized areas, where it is expected to be more difficult to site earthen type Treatment BMPs and structural Treatment BMPs may need to be incorporated. This price does not include right-of-way acquisition costs for constructing Treatment BMPs or for establishing drainage easements.

However, for Design Pollution Prevention and Treatment BMPs, project initiation cost estimating methods for the PPCE vary between districts based on district-specific conditions and regional requirements. Estimating for these BMPs should be coordinated with the appropriate district functional units and representatives.

Table F-2 can be used to determine the percentage of cost for Construction Site BMPs based on the total construction costs (not including right-of-way costs). To use Table F-2, add the adjustments that apply for the particular project and then multiply the total estimated construction cost by the total of adjustments.

Table F 2. Percentage of Extra Cost to Project Due to Construction Site BMPs	
Description	Recommended Adjustment (%)
Baseline Cost Percentage	1.25 ¹
Adjustment for Project Magnitude (Cost)	
\$0 to \$1,000,000	2.00
\$1,000,000 to \$1,500,000	1.25
\$1,500,000 to \$12,000,000	0.25
Greater than \$12,000,000	0.00
Adjustment for Location (RWQCB)	
Region 9 (San Diego)	0.75
All other Regions	0.00
Adjustment for Type of Project	
Highway Planting (Landscaping)	0.10
All other projects	0.00
Adjustment for Work near 303(d) Water Bodies	
Work near 303(d) Water Bodies	Project Specific ²
Adjustment for Project Specific Issues	
Project specific issues such as environmental sensitivity, monitoring, dewatering and discharge restrictions, permits, extreme construction conditions (coastal, mountain, urban), etc.	Project Specific ²
Total Adjustments for Water Pollution Control	(sum)

1 Baseline cost percentage of 0.75 is based upon actual construction costs for projects completed in 2003, 2004 and 2005 as described in the Water Pollution Cost Report prepared in 2005. (CT-SW-RT-05-138-04.1). Increase the baseline percentage to 1.25 or higher as necessary to reflect cost increases since 2005.

2 Engineer preparing estimate should discuss the cost implications of project specific issues with District/Regional NPDES Coordinator and District Construction Stormwater Coordinator.

Example:

For an interchange modification project consisting of structure widening, ramp realignment, and embankment construction, the estimated cost is \$16,000,000. The project is located in San Diego County and is within RWQCB Region 9. The project drains to an unlisted water body. The adjustment factor is based upon the following:

Baseline Cost Percentage	1.25
Greater than \$12,000,000	0.00
Adjustment for Location (RWQCB 9)	0.75
Adjustment for Type of Project	0.00
Adjustment for Work near 303(d) Water Bodies	0.00
Adjustment for Project Specific Issues	0.00
Total Adjustments for Water Pollution Control	2.00

The PID phase estimate for water pollution control is \$320,000 (\$16,000,000 x 2.00%).

F.3.2 Project Design Cost Estimate Method

This method is typically used during the PA/ED and PS&E phases of a project to develop the PPCE and the PECE. This method may be used at the PID phase when preliminary design information is available, or when Design Pollution Prevention and Treatment BMPs are estimated as separate line items and not included in other items of work (e.g., Erosion Control, Drainage). For this method refer to Section 1, Article 4 *Cost Estimate Pricing Methods in the Preparation Guidelines for Project Development Cost Estimates* (Cost Estimating Guidelines). See F.1.1 Policy and Guidance for more information. This document replaces Appendix AA of the PDPM Chapter 20. Table F-3 is a reference for planning level estimates; it lists a range of unit costs for Construction Site BMPs and is provided for convenience to identify typical ranges in costs for individual BMP line items. The *Caltrans Contract Item Database* should be used to develop specific line item estimates based on recent bids.



Table F 3. Installed Costs of BMPs ¹		
BEES	BMP	Unit Cost Installed
Temporary Sediment Control		
130670	Temporary Reinforced Silt Fence	\$6.00 – 14.00 per lineal foot
130640	Temporary Fiber Roll	\$3.50 – 11.00 per lineal foot
130680	Temporary Silt Fence	\$3.00 – 6.00 per lineal foot
130690	Temporary Straw Bale Barrier	\$11.00 – 16.00 per lineal foot
130650	Temporary Gravel Bag Berm	\$4.50 – 15.00 per lineal foot
130610	Temporary Check Dam	\$8.00 – 28.00 per lineal foot
130690	Temporary Straw Bale Barrier	\$11.00 – 16.00 per lineal foot
130620	Temporary Drainage Inlet Protection	\$165 – 375 each
130660	Temporary Large Sediment Barrier	\$9.00 – 15.00 per lineal foot
Temporary Tracking Control		
130710	Temporary Construction Entrance	\$3,000 – 6,000 each
130730	Street Sweeping	\$27,000 – 85,000 lump sum ²
130720	Temporary Construction Roadway	\$25 – 80 per square yard
Non-Stormwater Control		
130900	Temporary Concrete Washout	\$3,000 – 8,000 lump sum ²
Temporary Soil Stabilization		
130510	Temporary Mulch	\$3.00 – 15.00 per square yard
130250	Temporary Hydraulic Mulch	\$3.00 – 15.00 per square yard
130250	Temporary Hydraulic Mulch (Bonded Fiber Matrix)	\$3.00 – 15.00 per square yard
130250	Temporary Hydraulic Mulch (Cementitious Binder)	\$3.00 – 15.00 per square yard
130450	Temporary Tacked Straw	\$3.00 – 15.00 per square yard
130550	Temporary Hydroseed	\$3.00 – 15.00 per square yard
130560	Temporary Soil Binder	\$3.00 – 15.00 per square yard
130570	Temporary Cover	\$7.00 – 250 per square yard
Miscellaneous		
141000	Temporary Fence (Type ESA)	\$33.00 – 34.00 per lineal foot
TBD	Dewatering	Dependent on requirements
TBD	Temporary Stream Diversion System	\$40,000 – 85,000

Notes:

¹Unless otherwise noted, information derives from average bid costs using Caltrans Contract Cost Database for the period between 2013 and 2015.

²Costs for street sweeping and concrete washout should be derived using the methods described in the Construction Site BMP training materials.

F.3.3 Water Pollution Control Contract Bid Items

Use the following guidance to develop specific costs for the items identified to support the estimate for the PPCE and the PECE.

Prepare Water Pollution Control Program (Contract Bid Item: 130200)

Projects with less than one (1) acre of soil disturbance will have to include bid item Prepare Water Pollution Control Program (WPCP) to document implementation of the project’s water pollution controls. Small construction projects, between 1 and less than 5 acres of soil disturbance that qualify for an EPA Erosivity Waiver will also have to include bid item Prepare WPCP. Use Table F-4 to estimate the cost of Prepare WPCP.

Prepare Stormwater Pollution Prevention Plan (Contract Bid Item: 130300)

Projects subject to the Construction General Permit will have to include bid item Prepare Stormwater Pollution Prevention Plan (SWPPP). Use Table F-4 to estimate the cost of preparing the written document describing the implementation of the project’s water pollution controls. Prepare SWPPP includes the cost to prepare the Construction Site Monitoring Program (CSMP), which includes preparation of a Sampling and Analysis Plan (SAP) and implementation of visual monitoring.

Table F 4. Construction Site Water Pollution Control		
Total Construction Cost	Prepare SWPPP	Prepare WPCP
\$0 to \$500,000	\$2,200 + RQM	\$1,000
\$500,000 to \$1,000,000	\$2,700 + RQM	\$1,100
\$1,000,000 to \$1,500,000	\$2,800 + RQM	\$1,100
\$1,500,000 to \$12,000,000	\$3,200 + RQM	\$1,200
Greater than \$12,000,000	\$6,000 + RQM	-

Note: Information derived from 2009 average bid costs using Caltrans Cost Database with an additional mark-up to account for qualified developers of the SWPPP.

Routine Quarterly Non-Stormwater Monitoring (RL 1, 2, and 3): All projects required to develop a SWPPP regardless of the RL are to conduct quarterly, non-stormwater monitoring and storm-triggered visual monitoring. To develop cost estimates for routine quarterly monitoring (RQM) for non-stormwater discharges, Equation 1 below should be used. Equation 1 is a function of the project duration, the drainage area, and the cost per inspection. The costs for storm-triggered visual monitoring is assumed to already be included in the costs for preparing a SWPPP, as this was already a Caltrans requirement prior to the development of the *Construction General Permit* (CGP).

$$\text{RQM Cost} = (\text{months}/3 + 1) \times (N + 4) \times \text{Labor} \tag{Eqn. 1}$$

where:

Months = the number of months the project will be occurring, including from initial site work through the construction until soil is completely stabilized after construction. This is used to estimate the number of required quarterly inspections.

N = calculated number of project discharge locations. It is assumed that each discharge area can be reviewed within 1 hour. An additional 4 hours is provided to account for the time required to complete reporting and follow-up.

Labor = estimated hourly labor rate for a qualified inspector. Assume \$100 per hour is appropriate.

Job Site Management (Contract Bid Item: 130100)

This item is used on all projects.

Development of a cost estimate for Job Site Management (JSM) must be coordinated with the District or Regional Construction Coordinator. Estimates must account for project magnitude and duration considering dry and rainy seasons along with planned work suspensions. Previous job histories may be used or Job Site Management cost can be estimated using Equation 2 and Equation 3.

$$\text{JSM Cost} = \text{CPM}_{(\text{DRY})} \times \text{Months}_{(\text{DRY})} + \text{CPM}_{(\text{RAINY})} \times \text{Months}_{(\text{RAINY})} + \text{CPM}_{(\text{SUSP})} \times \text{Months}_{(\text{SUSP})} \tag{Eqn. 2}$$

$$\text{Total Working Months} = \text{Months}_{(\text{DRY})} + \text{Months}_{(\text{RAINY})} + \text{Months}_{(\text{SUSP})} \tag{Eqn. 3}$$

where:

CPM_(DRY) = cost multiplier based on the number of months with less than 1.0 days of mean precipitation of at least 0.5 inches. Consult with Construction for cost with expected range of \$2,000 to \$6,000.

CPM_(RAINY) = cost multiplier based on the number of months with at least 1.0 days of mean precipitation of at least 0.5 inches. Consult with Construction for cost with expected range of \$2,000 to \$7,000.

CPM_(SUSP) = cost multiplier based on the number of rainy season months where work is suspended. Consult with Construction for cost with expected range of \$0 to \$2,000.

Rain Event Action Plan (Contract Bid Item: 130310)

All RL 2 and RL 3 projects are to implement a Rain Event Action Plan (REAP) in advance of a forecasted storm. The contractor evaluates site readiness as part of formulating a REAP. This contract item is non-adjustable.

The PE is to set aside \$500 for each REAP that is anticipated to be prepared by the construction contractor. Estimate one REAP for every forecasted storm over 0.1-in during the planned construction period. Use the mean number of days reported for precipitation producing greater than or equal to 0.1 inches for the duration of the project. Otherwise, consult with the District Construction Stormwater Coordinator to use an alternative estimating procedure. Use climate data from a nearby representative station identified in the Water Quality Planning Tool or published by the National Climatic Data Center of the National Oceanic Atmospheric Association at: (<http://cdo.ncdc.noaa.gov/climatenormals/clim20/state-pdf/ca.pdf>).

Stormwater Annual Report (Contract Bid Item: 130330)

In order to account for the submittal of an annual report to the RWQCB regarding project compliance with the CGP, the PE should set aside \$2,000 for each year and partial year of construction. This contract item is non-adjustable.

Stormwater Sampling and Analysis Day (Contract Bid Item: 130320)

Sampling and analysis of stormwater runoff for pH and turbidity is required for all RL 2 and RL 3 projects. At a minimum, 3 samples must be collected per day of qualifying storm events, which are those producing precipitation of 0.5-inch or more at the time of discharge.

The cost of stormwater monitoring (SWM) is a function of the precipitation frequency, construction duration, and the number of sampling locations for the project, as well as the cost per sample. Unless an alternative method is available from the District/Regional Design Stormwater Coordinator, then the SWM cost is estimated using Equation 4 as follows:

$$\text{SWM Cost} = M \times \{[\text{Days}_{0.5"} \times \$1000] + \$2000 (1 + 0.1 (\text{Months}/12))\} \quad (\text{Eqn. 4})$$

where:

M = cost multiplier based on the number of anticipated discharge sampling points. When M = 1, the cost estimate assumes that up to 7 locations can be sampled by one fully equipped staff per event. Sites with 8 to 14 sampling locations assumes that one additional staff-day will be required, consequently, M=2. For sites with 15 – 21 sampling locations M=3, and so forth.

Days_{0.5"} = estimated number of days over project timeline with precipitation event greater than 0.5 inches. However, it is recommended that the difference between the mean number of days for both precipitation events greater than 0.5 inches and 0.1 inches be used. Use climate data from a nearby representative station identified in the Water Quality Planning Tool or published by the National Climatic Data Center of the National Oceanic Atmospheric Association at: (<http://cdo.ncdc.noaa.gov/climatenormals/clim20/state-pdf/ca.pdf>).

months = the number of months the project will be occurring, including from initial site work through the construction until the site is completely stabilized after construction.

\$1000 = daily cost to perform sampling and analysis, as well as reporting, using one staff at up to 7 discharge locations, excluding equipment.

\$2000 = purchase cost for field turbidimeter, pH meter, calibration solutions, rain gauge, and all ancillary sampling equipment. A maintenance and calibration estimate of 10 percent per year is included in the equation.

The cost of stormwater sampling and analysis per day can be estimated using Equation 5 as follows:

$$\text{Stormwater Sampling and Analysis Day} = \text{SWM Cost} / \text{Days}_{0.5} \quad (\text{Eqn. 5})$$

Receiving Water Bioassessment (RL 3)

Bioassessment monitoring is not a contract bid item, but is a capitol cost associated with projects.

Bioassessment monitoring in receiving waters is required for all RL 3 projects that exceed 30 acres of disturbed soil area and directly discharge runoff to a freshwater wadeable stream (or streams) that is either: (a) listed by the State Water Board of USEPA as impaired due to sediment, and/or (b) tributary to any downstream water body that is listed for sediment; and/or (c) have the beneficial use of SPAWN & COLD & MIGRATORY. Bioassessment monitoring is required both upstream and downstream of the impacted area, and both before and after the project. The after project monitoring can only be done after at least one winter season has transpired. The CGP contains an estimate of \$7,500 per year to cover the number of samples required for this type of work. Make sure to include bioassessment monitoring if the project meets the above criteria and include the cost.

F.3.3.1 Supplemental Costs

Additional Water Pollution Control (Contract Bid Item: 066596)

This item is required for all projects.

The Supplemental Work item for Additional Water Pollution Control will cover additional WPC BMPs suggested by the RE or Contractor. This change order work is expected to be minor for most projects. Estimate this item using the same rate as Prepare SWPPP, less RQM for SWPPP jobs. For WPCP jobs estimate at the same rate as Prepare WPCP.

Water Pollution Control Maintenance Sharing (Contract Bid Item: 066595)

This item is required for all projects.

The Supplemental Work item for Water Pollution Control Maintenance Sharing still exists but is generally incorporated into to the individual separate item BMPs that allow for cost sharing. Water Pollution Control Maintenance Sharing cost should be no lower than the amount estimated for Prepare SWPPP (or Prepare WPCP). The following may be used to estimate BMP maintenance costs based upon input from districts where this approach was piloted. The aggregate total of estimated maintenance costs would be combined into item WPC Maintenance Sharing:



- Temporary Silt Fence, estimate at 10 percent of the separate item cost per rainy season.
- Temporary Fiber Roll, estimate at 10 percent of the separate item cost per rainy season.
- Temporary Large Sediment Barrier, estimate at 10 percent of the separate item cost per rainy season.
- Temporary Erosion Control and other hydraulically applied temporary soil stabilization BMPs, estimate at 10 percent of the separate item cost per rainy season.
- Temporary Erosion Control Blanket, estimate at 10 percent of the separate item cost per rainy season.
- Temporary Cover, estimate at 10 percent of the separate item cost per rainy season.
- Temporary Gravel Bag Berm, estimate at 25 percent of the item cost per rainy season.
- Temporary Drainage Inlet Protection, estimate at 25 percent of the item cost per rainy season.
- Temporary Construction Entrance, estimate at 25 percent of the item cost per rainy season.

Stormwater Sampling and Analysis (Contract Bid Item: 066597)

The Supplemental Work item for Stormwater Sampling and Analysis will cover change order costs if the RE orders sampling and analysis. The anticipated use is for determining if materials associated with illegal dumping are contaminated or hazardous prior to cleanup. Another use is to address non-visible pollutants that may be exposed during excavation such as when unusual odors or soil conditions may occur and possible contamination or hazardous conditions must be determined.

This change order work is expected to be minimal, possibly non-existent, for most projects. It is not intended for this item to cover water quality sampling associated with 401 Certifications, other PLACs, or pH and turbidity sampling and analysis covered under other contract bid items (see section F.6 Water Quality Monitoring and Standard Specification 13-1.01C (4)).

Estimate at \$2,000 for SWPPP projects with a duration of one year or less. Estimate at \$2,000 - \$5,000 for SWPPP projects with a duration of more than a year. The higher ranges are justified in locations where the risk of illegal dumping is greater.

F.3.3.2 Department Furnished Materials

Annual Construction General Permit Fees (Contract Bid Item: 066916)

CGP fees are paid by construction as a Department Furnished Material. To calculate the CGP fees to a project first estimate the total project DSA, then calculate the fee based upon total DSA, then multiply the fee by the total number of years the project will be in construction.

$$\text{Annual CGP Fees} = [\$512 + (\text{DSA} \times \$51)] \times \text{Years} \tag{Eqn. 6}$$

where:

DSA = total DSA on the project. When DSA < 1, use DSA = 0. When DSA ≥ 1, round up to the nearest whole number

Years = total number of years the project will be in construction



Equation 6 is a conservative estimate of fees and does not account for discounts. Verify the CGP Fee Schedule on the SWRCB website prior to estimating for this item.

http://www.waterboards.ca.gov/resources/fees/water_quality/

F.4 Temporary Active Treatment System (Contract Bid Item: 130800)

There are two substantial components for the estimated costs of an ATS: construction and operations. In locations with large areas and low rainfall intensity, the overall cost would be dominated by the construction costs. Conversely, in a small working area located in a region with frequent rainfall, operational costs would be a more substantial portion of the overall ATS costs. The overall cost will vary substantially by construction activity and location.

The construction cost will be primarily composed of the selection of components for the ATS, collection and conveyance systems. Depending on the complexity required to meet water quality goals, different components will be needed. For example, a granular activated carbon filter may be needed for hydrocarbons, which will add to the construction cost. A larger construction area may also require greater size or number of filters, basins, and piping, all of which will increase construction cost.

The operational cost is made up of the amount of time the system is in use and the complexity of the system in question. Frequency of rainfall will vary with location. With greater frequency, the labor, power, and chemical costs will increase. As well, systems with greater complexity will require more work and monitoring prior to discharge.

It may be necessary, depending on the orientation of the construction area, to construct more than one system. The designer should prepare cost estimates for each ATS contributing drainage area.

F.4.1 Construction Costs

Construction costs will be a function of the size of the treatment system, the number of treatment systems, and the different components chosen. Each component will vary based upon the size. For example, the number of bag filters required will be dependent on the how the system is sized.

Table F 5. Construction Cost Estimate Per Year ¹			
System Components	200 GPM	500 GPM	1000 GPM
Required Components			
Treatment Pump	\$32,400	\$45,000	\$54,000
Coagulation Dosing Equipment	\$3,000	\$3,000	\$3,000
Sedimentation Basin	\$22,850	\$45,700	\$91,400
Monitoring Equipment ²	\$12,000	\$12,000	\$12,000
Power Generator	\$22,800	\$22,800	\$22,800
Optional Components			
pH Adjustment Equipment	\$3,000	\$3,000	\$3,000
Sand Filters w/ Backwash Tank	\$24,800	\$28,400	\$38,000
Bag/Cartridge Filters	\$18,000	\$42,000	\$66,000

¹ Prices Based on Vendor Quotes in 2010 Dollars

² Monitoring Equipment cost may vary based upon additional 401 or WDR requirements

Each treatment component will be added together to form a composite construction estimate. Some components are optional depending on the site conditions.

F.4.2 Operational Costs

Operational costs will be a function of the number of rain events in the specific location. The rainfall frequency can be determined by the report, “Monthly Station Climate Summaries, 1971-2000” provided by the Department of Commerce and the National Oceanic and Atmospheric Administration. In the document rainfall data at specific stations have been tabulated for the last 30 years. To determine rainfall frequency, first identify the closest station to the construction site. Second use the tables provided to find the annual number of rainfall events over 0.5 inches. The number can be used as the frequency of rain events the ATS system could potentially treat in a single year.

$$O = L + C + P \quad (\text{Eqn. 7})$$

O = Operational Costs, Dollars

L = Labor Cost, Dollars

C = Chemical Costs, Dollars

P = Power Costs, Dollars

The frequency of rainfall multiplied by the daily labor markup rate for an operator will equal the labor costs for a year of operation.

$$L = F \times W \times Y \quad (\text{Eqn. 8})$$

L = Labor Cost, Dollars

F = Rainfall Frequency, Events per Years

W = Daily Labor Markup, Dollars per Day

Y = Years of Operation, Years

The chemical costs will be both the coagulant costs and pH adjustment costs

$$C = G + A \quad (\text{Eqn. 9})$$

C = Chemical Costs, Dollars

G = Coagulant Cost, Dollars

A = Acid/Base Cost, Dollars

The frequency of rainfall multiplied by the expected coagulant dose, quantity of water treated and cost per pound of the coagulant, will give the expected coagulant costs. Coagulant dose will vary depending on coagulant selection; polymers will dose approximately 1 mg/L while metal salts (alum, ferric, etc.) will dose approximately 100 mg/L.

$$G = F \times D_c \times Q \times U_c \times Y \quad (\text{Eqn. 10})$$

G = Coagulant Cost, Dollars

F = Rainfall Frequency, Events per Year

D_c = Coagulant Dose, Gallons of Coagulant per Gallon of Water

Q = Quantity Water, Gallons



U_c = Unit Coagulant Cost, Dollars per Gallon

Y = Years of Operation, Years

Addition of Acid/Base addition will be determined by the receiving water requirements. The calculation will be similar to the coagulant cost calculation. The dose will vary depending on the choice of acids/bases.

$$A = F \times D_a \times Q \times U_a \times Y \quad (\text{Eqn. 11})$$

A = Acid/Base Cost, Dollars

F = Rainfall Frequency, Events per Year

D_a = Acid/Base Dose, Gallons of Acid/Base per Gallons of Water

Q = Quantity Water, Gallons

U_a = Unit Acid/Base Cost, Dollars per Gallon

Y = Years of Operation, Years

Power costs are a function of the frequency of rainfall and amount of power required to operate the system.

$$P = F \times U_p \times Y \quad (\text{Eqn. 12})$$

P = Power Costs

F = Rainfall Frequency, Events per Year

U_p = Unit Power Cost per Event, Dollars per Event

Y = Years of Operation

F.5 Temporary Stream Diversion System (Contract Bid Item: To Be Determined)

Temporary stream diversion system is the most common type of the clear water diversion BMP. It is typically a lump sum contract item covering the materials and labor involved in the installation, operation, and removal of the diversion.

To estimate the cost, evaluate the costs of the components and materials expected to be used and sum the number of temporary stream diversions anticipated for the project. Depending upon the components used such as pumps and inflatable coffer dams, the length of time the diversion is deployed may affect its cost.

Consider the example for culvert lining project near a small, perennial stream. The materials would likely be gravel bags and plastic liner for the coffer dam component, flexible plastic pipe for the culvert, and more gravel bags to secure and provide energy dissipation at the outlet.

Water quality monitoring is often a PLAC condition associated with in-water work such as temporary stream diversion systems. Water quality monitoring costs are covered under Contract Bid Item: 131103 WATER QUALITY SAMPLING AND ANALYSIS DAY, 131104 WATER QUALITY MONITORING REPORT, and 131105 WATER QUALITY ANNUAL REPORT. See F.6 for these Contract Bid Items.

F.6 Water Quality Monitoring

WATER QUALITY SAMPLING AND ANALYSIS DAY (Contract Bid Item: 131103)

Sampling and analysis of water quality under this item is used to address a PLAC requirement for in-water work such as temporary stream diversions. This is for work that is not related to CGP monitoring; project could have a WPCP or SWPPP.

The cost of water quality monitoring (WQM) is a function of construction duration, and the number of in-water work locations for the project, as well as the cost per sample. Unless an alternative method is available from the District/Regional Design Stormwater Coordinator, then the WQM cost is estimated using Equation 13 as follows:

$$\text{WQM Cost} = M \times \{[(\text{Days} + 2) \times \$1000] + \$2000\} \quad (\text{Eqn. 13})$$

where:

- M = cost multiplier based on the number of active, in-water work locations such as temporary stream diversion systems.
- Days = estimated number of days when in-water work will be performed. Include the day before installation and the day after removal.
- \$1000 = daily cost to perform sampling and analysis, as well as reporting, using one staff excluding equipment.
- \$2000 = purchase cost for field turbidimeter, pH meter, calibration solutions, rain gauge, and all ancillary sampling equipment. A maintenance and calibration estimate of 10% per year is included in the equation.

The cost of water quality sampling and analysis per day can be estimated using Equation 14 as follows:

$$\text{Water Quality Sampling and Analysis Day} = \text{SWM Cost} / \text{Days} \quad (\text{Eqn. 14})$$

WATER QUALITY MONITORING REPORT, (Contract Bid Item: 131104)

In order to account for the submittal of periodical reports to the RWQCB regarding project compliance with the 401 or other PLAC, the PE should set aside \$500 for each report. Typically, this is a monthly report required for the duration of in-water work. This item is not necessary for projects with SWPPPs as this information may be submitted as part of other CGP reporting. This contract item is non-adjustable.

WATER QUALITY ANNUAL REPORT (Contract Bid Item: 131105)

In order to account for the submittal of an annual report to the RWQCB regarding project compliance with the 401 or other PLAC, the PE should set aside \$2,000 for each year of construction. This item is not necessary for projects with SWPPPs as this information may be submitted as part of other CGP reporting. This contract item is non-adjustable.

THIS PAGE INTENTIONALLY LEFT BLANK.

**APPENDIX G: ABBREVIATIONS, ACRONYMS,
AND DEFINITION OF TERMS**



THIS PAGE INTENTIONALLY LEFT BLANK.

G.1 Abbreviations

a-f	acre-feet
cm	centimeter
cm/hr	centimeters per hour
cfs	cubic feet per second
fps	feet per second
' or ft	feet
ft ²	square feet
ft ³	cubic feet
g	gram
ha	hectares
h:v	horizontal:vertical
" or in	inches
"/hr or in/hr	inches per hour
hr(s)	hour(s)
kg	kilogram
kg/ha	kilograms per hectare
kg/m ²	kilograms per square meter
km	kilometer
l	liter
m	meter
mg	milligram
meq	milliequivalents
min	minute
mm	millimeter
m/s	meters per second
m ³	cubic meters
m ³ /yr	cubic meters/year
req'd	required
yd ³	cubic yard
yr	year
°C	degrees Celsius
>	greater than
≥	greater than or equal to
<	less than
≤	less than or equal to

G.2 Acronyms

A&E	Architectural & Engineering
AC	asphalt concrete
ACOE	Army Corps of Engineers
ADL	Aerially Deposited Lead
ADT	Annual Average Daily Traffic
ADL	Aerially Deposited Lead
A_p	Potential Stormwater Storage
APS	Advanced Planning Study
APHA	American Public Health Association
A_r	Area Required
ASBS	Areas of Special Biological Significance
ASCE	American Society of Civil Engineers
ASTM	American Society of Testing and Materials
ATA	Additional Treated Area
ATS	Active Treatment Systems
BAT	Best Available Technology
BCT	Best Conventional Technology
BCDC	Bay Conservation and Development Commission
BEES	Basic Engineering Estimating System
BFM	Bonded Fiber Matrix
BMP	Best Management Practice
BOD	Biochemical Oxygen Demand
BOD5	5-Day BOD
C/EP-SWAT	Construction/Encroachment Permit SWAT
Caltrans, CT	California Department of Transportation
CASQA	California Stormwater Quality Association
CBB	Cementitious Based Binders
CDA	Contributing Drainage Area
CDPH	California Department of Public Health



CE	Categorical Exemption/Exclusion
CEC	Cation Exchange Capacity
CEQA	California Environmental Quality Act
CFR	Code of Federal Regulations
CGP	Construction General Permit
CIP	Cast-in-Place
CMP	Corrugated Metal Pipe
CO2	Carbon Dioxide
CPP	Coagulant Prevention Plan
C-SWAT	Construction Stormwater Advisory Team
CS	Construction Site
CTC	California Transportation Commission
CU	Compliance Unit
CWA	Clean Water Act
DDT	Dichlorodiphenyltrichloroethane
DEA	Division of Environmental Analysis
DED	Draft Environmental Document
DES	Division of Engineering Services
DLA	District Landscape Architect
DPP	Design Pollution Prevention
DPR	Draft Project Report
DSA	Disturbed Soil Area
DTSC	Department of Toxic Substances Control
DWR	California Department of Water Resources
DWP	District Work Plan
EA	Expenditure Authorization
ED	Environmental Document
EDF	Evaluation Documentation Form
EPA	U.S. Environmental Protection Agency
EPP	Erosion Prediction Procedure

ESA	Environmentally Sensitive Area
ESC	Erosion and Sediment Control
ETWU	Estimated Total Water Use
FED	Final Environmental Document
FES	Flared End Section
FHWA	Federal Highway Administration
GI	Green Infrastructure
GIS	Geographic Information System
GSRD	Gross Solids Removal Device
GW	Groundwater
H₂CO₃	Carbonic Acid
H₂SO₄	Sulfuric Acid
HCL	Hydrochloric Acid
HDM	Highway Design Manual
HOV	High Occupancy Vehicle
HRT	Hydraulic Residence Time
HSG	Hydrologic Soil Group
HSS	Hydraulic Soil Stabilizers
HQ	Headquarters
IC	Impervious Covers
ISA	Initial Site Assessment
KP	Kilometer Post
LA	Landscape Architect
LID	Low Impact Development
MAWA	Maximum Applied Water Allowance
MCL	Maximum Contaminant Level
MCTT	Multi-Chamber Treatment Train
MEP	Maximum Extent Practicable
M-SWAT	Maintenance Stormwater Advisory Team
MS4	Municipal Separate Storm Sewer System

MWEL0	Model Water Efficient Landscape Ordinance
N	Nitrogen (elemental)
N2	Nitrogen (molecular) or Nitrogen gas
NAL	Numeric Action Limit
NaOH	Sodium Hydroxide
NEL	Numeric Effluent Limit
NEPA	National Environmental Policy Act
NH3	Ammonia
NH4+	Ammonium ion
NIS	New Impervious Surface
NNI	Net New Impervious
NO3-	Nitrate ion
NOAA	National Oceanic Atmospheric Administration
NOI	Notice of Intent
NOT	Notice of Termination
NPDES	National Pollutant Discharge Elimination System
NPRPD	National Pollutant Removal Performance Database
NRCS	Natural Resources Conservation Service
NS	Non-Stormwater Management
NTU	Nephelometric Turbidity Units
O&G	Oil and Grease
O&M	Operation and Maintenance
OC	Organic Content
OE	Office Engineer
OHSD	Office of Hydraulics and Stormwater Design
PA/ED	Project Approval/Environmental Document
PBL	Plant Material Based – Long Lived
PBS	Plant Material Based – Short Lived
PCB	Polychlorinated biphenyl
PC	Precast

PCC	Portland Cement Concrete
PCTA	Post Construction Treatment Area
PD-SWAT	Project Design Stormwater Advisory Team
PDCE	Project Design Compliance Evaluation
PDPM	Project Development Procedures Manual
PDT	Project Development Team
PE	Project Engineer
PEAR	Preliminary Environmental Assessment Report
PEB	Polymeric Emulsion Blends
PECE	Preliminary Engineer's Cost Estimate
PEE	Preliminary Environmental Evaluation
PGR	Preliminary Geotechnical Report
PID	Project Initiation Document
PLACs	Permits, Licenses, Agreements, Certificates
PM	Project Manager, Post Mile
POC	Pollutant of Concern
POTW	Publicly Owned Treatment Works
PPCE	Project Planning Cost Estimate
PPDG	Project Planning and Design Guide
PR	Project Report
PRB	Petroleum/Resin-Based Emulsion
PRD	Permit Registration Documents
PS&E	Plans, Specifications and Estimates
PSR	Project Study Report
R Factor	Rainfall Erosivity Factor
RE	Resident Engineer
REAP	Rain Event Action Plan
RECP	Rolled Erosion Control Products
RIS	Replaced Impervious Surface
RL	Risk Level

RO	Runoff
RRR	Resurfacing, Restoration & Rehabilitation projects
RSA	Rapid Stability Assessment
RSP	Rock Slope Protection
RTL	Ready-To-List
RUSLE	Revised Universal Soil Loss Equation
RW	Right of Way
RWQCB	Regional Water Quality Control Board
SAP	Sampling Analysis Plan
SBM	Standard Biodegradable Mulches
SC	Sediment Control
SCADA	Supervisory Control and Data Acquisition
SER	Standard Environmental Reference
SMARTS	Stormwater Multiple Application Report Tracking System
SS	Soil Stabilization, Settleable Solids
SSHM	Small Storm Hydrology Method
SSP	Standard Special Provisions
SUSMP	Standard Urban Stormwater Mitigation Plan
SW	Stormwater
SWAT	Stormwater Advisory Team
SWDR	Stormwater Data Report
SWMP	Statewide Stormwater Management Plan
SWPPP	Stormwater Pollution Prevention Plan
SWRCB	California State Water Resources Control Board
TBMP	Treatment Best Management Practice
TC	Tracking Control
TDC	Targeted Design Constituent
TDS	Total Dissolved Solids
TKN	Total Kjeldahl Nitrogen
TMDL	Total Maximum Daily Load

Total Ortho-P	Total Ortho Phosphate
TP	Total Phosphorous
TPPIA	Total Post Project Impervious Area
TRPA	Tahoe Regional Planning Agency
TS	Temporary Seeding
TSS	Total Suspended Solids
TST	Traction Sand Traps
UNK	Unknown
USA	Underground Service Alert
USDA	United States Department of Agriculture
USEPA	United States Environmental Protection Agency
USCS	Unified Soil Classification System
USGS	United States Geological Survey
UV	Ultraviolet
WBS	Work Breakdown Structure
WDR	Waste Discharge Requirement
WE	Wind Erosion Control
WEF	Water Environment Federation
WLA	Waste Load Allocations
WM	Waste Management
WPC	Water Pollution Control
WPCP	Water Pollution Control Program
WQ-SWAT	Water Quality Stormwater Advisory Team
WQ	Water Quality
WQAG	Water Quality Assessment Guidelines
WQAR	Water Quality Assessment Report
WQF	Water Quality Flow
WQO	Water Quality Objectives
WQPT	Water Quality Planning Tool
WQV	Water Quality Volume

G.3 Definition of Terms

Bolded items in the following text signify that the definition can be found in this Appendix.

5-Day Biochemical Oxygen Demand (BOD) Test:

BOD refers to the oxygen used in meeting the metabolic needs of aerobic microorganisms in water containing organic matter. The higher the level of organic matter, the higher the BOD. For example, water polluted with sewage would have a high BOD.

The 5-day BOD test (BOD₅) measures the rate of oxygen required by microorganisms (i.e., a laboratory inoculation) to oxidize the biodegradable matter in a sample under controlled laboratory test conditions. High BOD results (usually the result of organic contamination) suggest that the dissolved oxygen levels in **receiving water** may be depleted.

303(d) List:

The 303(d) list is a list of **water bodies** that have one or more **beneficial uses** that are impaired by one or more pollutants. The 303(d) list is required by Section 303(d) of the federal **CWA**. Water bodies included on this list are referred to as “impaired waters.” The State must take appropriate action to improve impaired water bodies, such as development of a **TMDL**.

Aerially Deposited Lead (ADL):

Lead is an inorganic metal found at varying concentrations in the natural environment. Tetraethyl lead was added to gasoline until the mid-1980s. Particulate emissions in the leaded gasoline exhaust contain lead, which was deposited adjacent to roadways as aerial deposited lead (ADL). Refer to the Caltrans Hazardous Waste ADL Guidance and the ADL Agreement for requirements regarding management of soil containing ADL.

Additional Treated Area (ATA):

When project circumstances require treatment beyond the **NIS**, the additional area required to be treated is referred to as ATA. ATA is determined by evaluating two conditions: 1) If an existing **Treatment BMP** is removed or modified by the project, or if any portion of its contributing drainage area cannot continue to be treated by the existing **Treatment BMP**, then that **impervious area** and **pervious area** shall, at a minimum, be treated by the project, excluding any **RIS** within the existing **Treatment BMPs CDA** and 2) Where the **NNI** for the project is greater than 50 percent of the total post-project **impervious area**, then the entire impervious area shall be treated.

Alternative Compliance:

Alternative compliance must be used if it is technically infeasible, or cost-prohibitive to incorporate **Treatment BMPs** on a **new development or redevelopment project**. Until a statewide plan is approved by the Executive Director of the SWRCB, Caltrans will develop an alternative compliance strategy for each project for approval by the RWQCB Executive Officer or his designee. The proposal will include documentation supporting the determination of infeasibility. The alternative compliance strategy may be proposed outside project limits within Caltrans’ right-of-way, including within another Caltrans project, and provisions for long-term maintenance of such treatment facilities must be included.

Alternative Compliance can be generated by a project when a **Treatment BMP** is designed to treat more than the **NIS** and when **ATA 1** are met. This additional treatment can be banked for the use on a project that cannot incorporate **Treatment BMPs**, as long as it is within the same watershed. Note, if the additional treatment is within a TMDL watershed, then it can be otherwise used towards meeting the Caltrans TMDL requirements (**Compliance Units**).

Area of Special Biological Significance (ASBS):

The State Water Resources Control Board has designated 34 coastal marine waters as ASBS in the California Ocean Plan. ASBS are coastal areas requiring protection of species or biological communities. The Department discharges stormwater into ASBS locations shown in Table 4-1. Discharges to ASBS are prohibited, so new discharges might require redirection to a location outside of the ASBS.

ASBS Locations					
Caltrans District	ASBS Number	ASBS Name	County	Route	Postmile
1	8	Redwood National and State Parks	Del Norte	101	11.3 - 15.4
			Humbolt	101	117.3 - 123.8
	5	Kelp Beds at Saunders Reef	Mendocino	1	9.8 - 10.8
4	15	Ano Nuevo Point and Island	San Mateo	1	0.0 - 3.0
	9	James V Fitzgerald Marine Reserve	San Mateo	1	33.8 - 36.3
5	20	Ocean Area Surrounding the Mouth of Salmon Creek	Monterey	1	0.0 - 4.0
	18	Julia Pfeiffer Burns Underwater Park	Monterey	1	35.0 - 38.0
	16	Point Lobos Ecological Reserve	Monterey	1	70.0 - 71.0
	34	Carmel Bay	Monterey	1	71.0 - 75.5
7	24	Mugu Lagoon to Latigo Point	Ventura	1	0.0 - 11.0
			Los Angeles	1	50.0 - 63.0
12	33	Irvine Coast Marine Life Refuge	Orange	1	12.0 - 15.0

Basin Plan:

A Basin Plan is a water quality control plan developed by each **RWQCB** to identify designated **beneficial uses** and water quality objectives for the **water bodies** and watershed areas within that specific region.

Basin Sizer:

Basin Sizer is a software tool developed to help engineers and designers calculate **WQVs** and **WQFs** for sizing of treatment devices by methods approved for Caltrans. The software allows easy selection of rainfall stations through a graphical interface of a map of California, which shows rainfall stations, state and federal highways, and rivers. The Caltrans tab determines the precipitation depth in inches from the 85th percentile, 24-hour storm event based on the station or stations selected. This depth is then used with the SSHM to obtain the project **WQV**. Additionally, Basin Sizer includes options for WQV sizing using the Maximized Volume Method, California Stormwater BMP Handbook Approach, and Urban Runoff Quality Management Approach in the Historic and CASQA tabs.

Beneficial Uses:

Streams, lakes, rivers, and other water bodies, have uses to humans and other life; these uses are referred to as the Beneficial Uses of a water body. The beneficial uses of waters in California are described in the Basin Plans adopted by the nine California RWQCBs. Section 13240 of the California Water Code requires adoption of water quality control plans, called Basin Plans, for the protection of water quality within the State's watersheds. **Discharges** from stormwater drainage systems may convey **pollutants** to waters of the State, and therefore may have an adverse impact on the beneficial uses of that water resource. Beneficial uses fall into one or more of the following categories:

- Agricultural Supply (AGR) – water used for irrigation, leaching of salts, stock watering, etc.;
- Industrial Service Supply (IND) – use of water for industrial activities that do not depend primarily on water quality;
- Industrial Process Supply (PRO) – uses of water that depend primarily on water quality;
- Groundwater Recharge (GWR) – replenishment of **groundwater** by percolation from surface waters;
- Municipal and Domestic Supply (MUN) – water supply systems including drinking water supply;
- Freshwater Replenishment (FRSH) – maintenance of surface water quality or quantity;
- Cold Freshwater Habitat (COLD) – maintenance of cold water ecosystems;
- Warm Freshwater Habitat (WARM) – maintenance of warm water ecosystems;
- Estuarine Habitat (EST) – habitat resulting from commingling of freshwater and saltwater;
- Wildlife Habitat – (WILD) water used to support terrestrial or aquatic ecosystems;
- Preservation of Biological Habitats of Special Significance (BIOL) – water used to support designated areas such as refuges, parks or sanctuaries;
- Spawning, Reproduction, and/or Early Development (SPWN) - water used to support aquatic habitats suitable for reproduction and early development of fish;
- Migration of Aquatic Organisms (MIGR) – water used to support migration or other temporary aquatic organism uses;
- Rare, Threatened, or Endangered Species (RARE) – water used to support aquatic habitats necessary for the survival and maintenance of rare, threatened or endangered species;
- Aquaculture (AQUA) – using water for the propagation, cultivation, maintenance, or harvesting of aquatic plants or animals;
- Shellfish Harvesting (SHELL) – water used to support habitats for the maintenance of filter feeding shellfish;
- Commercial and Sport Fishing (COMM) – collecting fish for commercial or recreational purposes;
- Hydropower Generation (POW) – water used to produce electricity;
- Navigation (NAV) – the use of water for shipping or travel;



- Water Contact Recreation (REC-1) – recreational activities involving body contact with water; and
- Non-Contact Water Recreation (REC-2) – recreational activities involving proximity to water, but generally no body contact or ingestion of water.

Best Available Technology (BAT):

BAT is a term derived from Section 301(b) of the **CWA** and refers to **BMPs** to reduce toxic and non-conventional **pollutants** in **discharges** from **construction sites**. Toxic pollutants are those defined in Section 307 (a)(1) of the **CWA** and include heavy metals and man-made organics. Non-conventional pollutants are those not covered by conventional and toxic pollutants, such as ammonia, chloride, toxicity and nitrogen.

Best Conventional Technology (BCT):

BCT is a term derived from Section 301(b) of the federal **CWA** and refers to **BMPs** to reduce conventional **pollutants** in **discharges** from **construction sites**. Conventional pollutants include **TSS**, oil and grease, fecal coliforms, pH and other pollutants.

Best Management Practice (BMP):

A BMP is a measure that is implemented to protect water quality and reduce potential for pollution associated with stormwater **runoff**. Any program, technology, process, siting criteria, operating method, or device that controls, prevents, removes, or reduces pollution. There are four categories of BMPs: Maintenance, Design Pollution Prevention, Construction Site, and Treatment:

Maintenance BMPs:

Maintenance BMPs are water quality controls and practices used to reduce pollutant discharges during highway maintenance activities and activities conducted at maintenance facilities. These BMPs are technology-based controls that attain MEP pollutant control. This category of BMPs includes litter pickup, toxics control, street sweeping, etc.

Design Pollution Prevention (DPP) BMPs:

Design Pollution Prevention BMPs are permanent water quality controls used to reduce pollutant discharges by preventing **erosion** and promoting infiltration. If the BMP infiltrates, it can be considered a **Treatment BMP** (e.g., DPP Infiltration Area). These BMPs are standard technology-based, non-treatment controls selected to reduce pollutant discharges to the **MEP** requirements. They are applicable to all projects. This category of BMPs includes: consideration of downstream effects related to potentially increased flow, such as reduction of paved surface, and soil modification; preservation of existing vegetation and soils, and stream buffer areas; concentrated flow conveyance systems, such as ditches, berms, dikes, swales, overside drains, outlet protection/velocity dissipation devices; and slope/surface protection systems such as vegetated surfaces and hard surfaces.

Construction Site BMPs:

Construction Site BMPs are temporary controls used to reduce or eliminate pollutant discharges during construction. These controls are best conventional technology/best available technology

BCT/BAT based BMPs that may include **soil stabilization**, sediment control, wind **erosion** control, tracking control, non-stormwater management and waste management.

Treatment BMPs:

Treatment BMPs are permanent water quality controls used to remove pollutants from stormwater **runoff** prior to being discharged from Caltrans right-of-way. These controls are used to meet **MEP** requirements and are considered for projects discharging directly or indirectly to **receiving waters**. This category of BMPs includes: Traction Sand Traps, Infiltration Devices, Detention Devices, Biofiltration Systems, Dry Weather Flow Diversion, Media Filters, Multi-Chamber Treatment Trains, Wet Basins, **GSRDs**, and DPP Infiltration Areas.

California Department of Public Health (CDPH):

The California DPH (<http://www.cdph.ca.gov/>) is a State Government department created to protect and improve the health of Californians. CDPH is concerned about the potential of any **BMP** device creating a public hazard by increasing habitat availability for aquatic stages of mosquitoes, and by creating harborage, food, and moisture for other reservoirs and nuisance species.

California Environmental Quality Act (CEQA):

The CEQA of 1970 requires public agencies to prevent significant, avoidable damage to the environment by regulating activities that may affect the quality of the environment. Public agencies accomplish this by requiring projects to consider the use of alternatives or mitigation measures. Regulations for the implementation of CEQA are found in the CEQA Guidelines and are available online by the California Natural Resources Agency at <http://resources.ca.gov/ceqa/>.

Caltrans Permit:

Caltrans Permit refers to the **NPDES** Statewide Stormwater Permit issued to Caltrans in 2012 (Order 2012-0011-DWQ as amended by Order WQ 2014-0006-EXEC, Order WQ 2014-0077-DWQ, and Order WQ 2015-0036-EXEC) (CAS000003), to regulate stormwater discharges from Caltrans facilities.

Categorical Exemption (CE):

A CE is a list of classes of projects that have been determined not to have a significant effect on the environment and which shall, therefore, be exempt from the provisions of **CEQA**. For a list of classes of projects and further information see the web site:

<http://www.resources.ca.gov/ceqa/guidelines/art19.html>

Clean Water Act (CWA):

The CWA, originally enacted by Congress in 1972, is a federal law that requires states to protect, restore, and maintain the quality of the waters of the United States, including lakes, rivers, aquifers and coastal areas. The CWA, as amended in 1987, is the enabling legislation for the **NPDES** permitting process.

Code of Federal Regulations (CFR):

The CFR is a document that codifies all rules of the executive departments and agencies of the federal government. It is divided into 50 volumes, known as titles. Title 40 of the CFR (referenced



as 40 CFR) contains all environmental regulations. 40 CFR is available from bookstores operated by the Government Printing Office and online at: <http://www.epa.gov/epahome/cfr40.htm>.

Common Plan of Development:

A common plan of development is generally a contiguous area where multiple separate and distinct construction activities may be taking place at different times on different schedules under one plan. Although many Caltrans construction contracts include work at various locations, do not assume that all locations are considered as part of a “larger common plan of development”. As per EPA ruling, non-contiguous construction sites separated by ¼ mile or more, included into a single contract for administrative convenience, should not be considered part of a larger common plan of development. The aggregate DSA for individual locations should not be totaled as a check for **CGP** coverage. However, if a single location has more than 1 acre DSA, then the **CGP** applies for that location.

Compliance Unit (CU):

Any project within a designated **TMDL** watershed where Caltrans is a named stakeholder, that provides treatment to areas (pervious or impervious) not exclusively set aside to meet post construction treatment requirements may generate CUs for the Department. CUs can be credited to the Department in the PID phase.

Construction General Permit (CGP):

The CGP is a Statewide General Permit for construction activities (Order No. 2009-0009-DWQ (as amended by 2010-0014-DWQ and 2012-0006-DWQ) (CAS000002) that applies to all stormwater discharges from activities that result in a **DSA** of at least one acre or more.

Construction Site:

The term “construction site” should apply to all areas both within the construction limits on state right-of-way and areas that are directly related to the construction activity, including but not limited to staging areas, storage yards, material borrow areas and storage areas, access roads, barges or platforms, etc., whether or not they reside within the Caltrans right-of-way.

Construction Site Best Management Practices Manual:

The Construction Site Best Management Practices Manual provides instructions for the selection and implementation of Construction Site **BMPs**. Caltrans requires contractors to identify and utilize these BMPs in preparation of their **SWPPP** or **WPCP**.

Contributing Drainage Area (CDA):

The upstream drainage area of a **Treatment BMP** or any area of land where precipitation collects and drains to a specific location.

Department of Toxic Substances Control (DTSC):

The DTSC (<http://www.dtsc.ca.gov/>) is the department within the California **EPA** that has responsibility for regulating the generation, management, and disposal of hazardous wastes. Caltrans has an ADL Agreement with DTSC for management of soil containing regulated levels of

ADL. Please refer to your hazardous waste coordinator or the Caltrans Hazardous Waste ADL Guidance for specifics on lead concentrations and requirements.

Department of Water Resources (DWR):

The California DWR (<http://www.dwr.water.ca.gov/>) is a State Government department created to manage the water resources of California in cooperation with other agencies in such a way as to benefit the State's people, and to protect, restore, and enhance the natural and human environments. The DWR is a source for hydrology data, **groundwater** information, water maps, etc.

Design-Build Project:

Design-Build is a project delivery method in which design and construction services are contracted by a single entity known as the design-builder. Design-Build projects must follow the Caltrans Permit requirements, highway design manual, and other appropriate highway standards.

The Department implements design-build projects through a demonstration program. Information about the program can be found on the following website:

<http://design.onramp.dot.ca.gov/project-requirements-template>

The Design-Build team develops a SWDR using the drainage information and previous Stormwater Data Reports provided by Caltrans, if available. The design of stormwater BMPs follows the requirements contained in the PPDG, Environmental Document, Permits, and design guidance to develop a final SWDR, and PS&E documents. Design-Build documents are dynamic documents that are routinely updated as the project progresses.

District Work Plan (DWP):

DWPs (formerly Regional Work Plans) are annual detailed plans that describes when and how the various programs and BMPs contained in the **SWMP** will be implemented by each district in each RWQCB jurisdictional area for the upcoming fiscal year.

Discharge:

The term “discharge” refers to the amount of water flowing out of a drainage structure or facility. It is measured in cubic feet/second. It is any release, spill, leak, pump, flow, escape, dumping, or disposal of any liquid, semi-solid or solid substance.

Disturbed Soil Area (DSA):

Disturbed soil areas are areas of exposed, erodible soil that are within the construction limits and that result from construction activities. DSA does not include **routine maintenance** activity to maintain existing highways (facilities) or preventative maintenance to maintain highway structures, and existing functions. Asphalt concrete, Portland cement concrete, aggregate base, shoulder backing, bridge decks, sidewalks, buildings, road side ditches, gutters, dikes, and culverts are all part of existing highway facilities. Activities necessary to implement landscape and highway planting projects are not considered DSA for triggering **CGP** coverage.

Construction activity in the context of **NPDES** stormwater and CWA is defined by EPA: “commencement of construction” as the initial disturbance of soils associated with clearing, grading, or excavating activities or other construction activities (63 CFR 7913). This does not



include routine maintenance of highway facilities.” For example, an AC overlay with a thin lift of shoulder backing on top of an existing facility is routine maintenance and has no DSA.

Dual Purpose Facility:

Dry Weather Flow Diversion and flood control basins are considered dual purpose facilities. These types of facilities can be used to meet treatment requirements and should be considered.

Erosion:

Erosion is the wearing away of earth surfaces by the action of external forces. In the case of drainage terminology, this term generally refers to the wearing away of the earth’s surface by flowing water or wind.

Existing Vegetation:

Existing vegetation is any plant material within the project limits that is present prior to the beginning of construction.

Full Capture Multi Benefit BMPs:

Trash Full Capture Multi Benefit BMPs, are certified for trash full capture and also effective at removing other pollutants, they are a preferred treatment method, because they remove multiple pollutants.

Geographic Information System (GIS):

GIS is a system of hardware and software used for storage, retrieval, mapping, and spatial analysis of geographic data.

Green Infrastructure (GI):

- Green infrastructure is an approach to stormwater management and flood mitigation that provides areas for water to soak into the ground, or evaporate back into the air, rather than forming runoff. A green infrastructure approach to stormwater management and flood risk reduction seeks to capture rainwater as close to where it falls as possible and let that water soak back into the ground (EPA 2018).
- Green Infrastructure stormwater BMPs appropriate for highways include: Bioretention, Biofiltration swales, Biofiltration strips, Wet Basins, Infiltration Basins, Infiltration Trenches, Infiltration Galleries, and Design Pollution Prevention Infiltration Areas. Furthermore, Caltrans designs other green infrastructure for purposes beyond stormwater, these include vegetated revetments, fish passage, slope stabilization, and stream bank stabilization.

Groundwater (GW):

GW is defined as the water that is naturally occurring under the earth’s surface. It is situated below the surface of the land, irrespective of its source and transient status. Subterranean streams are flows of GW parallel to and adjoining stream waters, and usually determined to be integral parts of the visible streams. GW is considered a jurisdictional water of the State under the Porter-Cologne Water Quality Act (California Water Code, Division 7).

High Risk Areas:

High Risk Areas are defined as municipal or domestic water supply reservoirs or **groundwater** percolation facilities discharging to aquifers designated as water supply sources.

Highway Design Manual (HDM):

The HDM is a Caltrans document that establishes uniform policies and procedures to carry out the highway design functions of Caltrans.

Impervious Surface:

An impervious surface is any surface that cannot effectively absorb or infiltrate rainfall. This includes PCC and AC highways, roads, parking lots, and sidewalks. It also includes building, structures, and roofs.

Litter:

Litter in stormwater is defined by Caltrans as manufactured objects made from paper, plastic, cardboard, glass, metal, etc. This definition does not include materials of natural origin such as gravel or vegetation. Litter in surface waters can inhibit the growth of aquatic vegetation, harm aquatic organisms by ingestion or entanglement, convey other **pollutants** and cause aesthetic problems on shorelines.

Low Impact Development (LID):

LID is a stormwater management strategy aimed at maintaining or restoring the natural hydrologic functions of a site to achieve natural resource protection objectives. LID employs a variety of natural and engineered features that reduce the rate of runoff, filter pollutants out of runoff, and facilitate the infiltration of water into the ground.

Maximum Contaminant Level (MCL):

The MCL is the highest level of a contaminant that is allowed in drinking water.

Maximum Extent Practicable (MEP) Analysis:

The MEP analysis is the process of evaluating the selected **BMPs** based on legal and institutional constraints, technical feasibility, relative effectiveness, and cost/benefit ratio.

Metals (Total and Dissolved):

Metals, both total and dissolved, are commonly monitored constituents and, next to **TSS** and **nutrients**, are the most common constituents cited in the literature as being present in stormwater runoff.

Trace quantities of many metals are necessary for biological growth and may naturally occur in runoff. Most metals, however, have numeric water quality standards because of their toxicity to aquatic organisms at high concentrations.

The toxicity of some metals is inversely related to water hardness. The numeric water quality standards for cadmium, chromium, copper, lead, nickel, silver and zinc are hardness-dependent. Copper, lead and zinc are the metals most commonly found in highway runoff.

Municipal Separate Storm Sewer System (MS4):

MS4s are storm drain systems regulated by the federal Phase I and Phase II stormwater regulations. Municipal combined sewer systems are regulated separately. MS4s are defined in the federal regulations at 40 **CFR 122.26(b)(8)**. Caltrans is designated as a Phase I MS4 permittee.

National Environmental Policy Act (NEPA):

The NEPA of 1969 establishes policies and procedures to bring environmental considerations into the planning process for federal projects. NEPA requires all federal agencies to identify and assess reasonable alternatives to proposed actions that will restore and enhance the quality of the human environment and avoid or minimize adverse environmental impacts. The NEPA process is an overall framework for the environmental evaluation of federal actions.

National Pollutant Discharge Elimination System (NPDES) Permit:

The NPDES Permit is **EPA's** program to control the **discharge** of **pollutants** to waters of the United States. NPDES is a part of the federal **CWA**, which requires point and non-point source dischargers to obtain permits. These permits are referred to as NPDES permits.

Natural Resources Conservation Service (NRCS):

As part of the USDA, the NRCS provides leadership in a partnership effort to help people conserve, maintain, and improve natural resources and the environment. Soil types and local soil survey data can be obtained from the NRCS soil maps. The soil type and soil survey data are used during the desktop screening of potential Infiltration Device sites.

New Development/Redevelopment Projects:

As defined in the Caltrans Permit, new development and redevelopment projects are those that create, add and/or replace impervious surfaces. The replacement of impervious surfaces includes any location where existing impervious surfaces have been removed such that the underlying soil or pervious subgrade has been exposed. New development or redevelopment activities do not include routine maintenance that maintain original line and grade, hydraulic capacity, or original purpose of the facility, nor does it include emergency construction activities required to protect public health and safety. In addition, redevelopment projects do not include trenching and resurfacing associated with utility work; pavement grinding and resurfacing of existing roadways; construction of new sidewalks, pedestrian ramps, or bike lanes on existing roadways.

Net New Impervious Area (NNI):

Net New Impervious Area is the total **impervious area** added to a project, after reductions for any **impervious areas** that have been removed from the project including excluded impervious areas (Table 4-1).

New Impervious Surface (NIS)

The project new impervious surface (NIS) is the addition of the **NNI** and the **RIS**.

Nutrients:

Nutrients are nutritive substances such as phosphorous and nitrogen whose excessive input into **receiving waters** can over-stimulate the growth of aquatic plants.

Algae and vascular plants can cause numerous deleterious effects. Algae and vascular aquatic plants produce oxygen during the day via photosynthesis and consume oxygen during the night via respiration. The pH of the water is linked to this phenomenon through the carbonate cycle: the pH rises during the day when carbon dioxide (CO₂) is consumed for the photosynthetic production of plant tissue and falls at night when CO₂ is released by respiration. Algal blooms due to inputs of nitrogen or phosphorus can cause wide fluctuations in this dissolved oxygen and pH cycle during a 24-hour period, which can cause fish kills and mass mortality of benthic organisms. In addition, excessive algal and vascular plant growth can accelerate eutrophication, interfere with navigation, and cause unsightly conditions with reduced water clarity, odors, and diminished habitat for fish and shellfish.

Other trace nutrients, such as iron, are also needed for plant growth. In general, however, phosphorus and nitrogen are the nutrients of importance in aquatic environments.

Phosphorus. Phosphorus is taken up by algae and vascular aquatic plants and, when available in excess of the plant's immediate needs for metabolism and reproduction, can be stored in the cells. With bacterial decomposition of plant materials, relatively labile pools of phosphorus are later released and recycled within the biotic community. The refractory portion (i.e., compounds relatively resistant to biodegradation) tends to sink to the bottom, where it degrades slowly over time.

Analytical tests for the minimum constituent list include TP, which is the sum of the dissolved and particulate orthophosphate, polyphosphate and organic phosphorus; and Total Ortho-P, which is the sum of the dissolved and particulate orthophosphate.

Nitrogen. Transformation of nitrogen compounds can occur through several key mechanisms: fixation, ammonification, synthesis, nitrification, and denitrification. Nitrogen fixation is the conversion of nitrogen gas into nitrogen compounds that can be assimilated by plants; biological fixation is the most common, but fixation can also occur by lightning and through industrial processes. Ammonification is the biochemical degradation of organic-N into NH₃ or NH₄⁺ by heterotrophic bacteria under aerobic or anaerobic conditions. Synthesis is the biochemical mechanism in which NH₄⁺-N or NO₃⁻-N is converted into plant protein (Organic-N); nitrogen fixation is also a unique form of synthesis that can be performed only by nitrogen-fixing bacteria. Nitrification is the biological oxidation of NH₄⁺ to NO₃⁻ through a two-step autotrophic process by the bacteria *Nitrosomonas* and *Nitrobacter*; the two-step reactions are usually very rapid, and hence it is rare to find nitrite levels higher than 1.0 mg/l in water. The nitrate formed by nitrification is, in the nitrogen cycle, used by plants as a nitrogen source (synthesis) or reduced to N₂ gas through the process of denitrification; NO₃⁻ can be reduced, under anoxic conditions, to N₂ gas through heterotrophic biological denitrification.

Analytical tests for the minimum constituent list include NH₃/NH₄⁺-N, NO₃⁻-N, and Total TKN. TKN is a measure of NH₃/NH₄⁺-N plus organic-N; the concentration of organic-N is thus obtained by subtracting the concentration of NH₃/NH₄⁺-N found in the sample from that of the TKN value.

Pathogens:

Pathogens include viruses, bacteria, protozoa, and possibly helminth worms and are a concern in stormwater runoff. The direct measurement of specific pathogens in water is extremely difficult.

The coliform group of organisms is commonly used as an indicator of the potential presence of pathogens of fecal origin.

Sources of total and fecal coliforms in stormwater runoff are ubiquitous (e.g., soil particles, droppings of wild and domestic animals). Human sources could include illegal encampments, illegal sewer connections, and seepage from septic tanks.

Pervious Surface:

A pervious surface is any surface that can absorb or infiltrate rainfall. This includes soil, pervious pavements, gravel roads, shoulder backing, embankments, fills, rock slope protection, gravel, and mulches.

Pesticides:

A pesticide is a chemical agent designed to control pest organisms. The most common forms of pesticides are organic chemicals designed to target insects (insecticides) and vascular plants (herbicides).

Chlorpyrifos and Diazinon. Chlorpyrifos and Diazinon are organophosphate pesticides that have been detected in stormwater **runoff**. Organophosphates exhibit a high pesticidal activity and relatively low persistence in the environment. They also exhibit acute toxicity effects to humans and animals by inhibiting the acetylcholinesterase enzyme activity at nerve endings, which affects the proper functioning of the nervous system. Absorption through the skin is a major route of exposure for all organisms.

Pollutant:

Any constituent present in sufficient quantity to impair the beneficial uses of a receiving water body.

Post Construction Treatment Area (PCTA):

The PCTA is the impervious area required to be treated by the project and includes the **NIS** and **ATA** (Condition 1 Impervious and Condition 2).

Primary Pollutant of Concern:

A "Primary Pollutant of Concern" is a constituent that has been identified as a **Targeted Design Constituent** by the Department and for which a receiving water body of interest is listed on the 303(d) list.

Project Development Procedures Manual (PDPM):

The PDPM describes the policies and procedures to be followed by Caltrans for State highway project development.

Project Development Team (PDT):

The PDT guides and develops specific projects. The PDT is typically managed by a district PM and is supported by functional managers and units.



Project Limits:

The project limits are between “Begin Work” and “End Work” as shown on the title sheet of the project plans. Note that no construction of a permanent nature beyond the construction limits of the project is allowed. Construction limits are between “Begin Construction” and “End Construction” as shown on the title sheet of the project plans.

R Factor:

Erosivity factor used in the Revised Universal Soil Loss Equation (RUSLE). The R factor represents the erosivity of the climate at a particular location. An average annual value of R is determined from historical weather records using erosivity values determined for individual storms. The erosivity of an individual storm is computed as the product of the storm's total energy, which is closely related to storm amount, and the storm's maximum 30-minute intensity.

This R-factor can be calculated using the EPA calculator (or tabular method) in the determination of erosivity waiver and for determining the **CGP** sediment risk level. See *Risk Level Determination Guidance* for more details.

Rapid Stability Assessment:

Assessment of the susceptibility of a channel reach to accelerated **erosion** or deposition in response to planned hydromodification. RSAs of each Threshold Drainage Area generally require no more than a few hours of effort by trained professionals working in the office followed by a visual field inspection of the reach in question.

Receiving Water:

A river, lake, ocean, stream or other watercourse into which storm water, wastewater, or treated effluent is discharged as provided in the “Terms of Environment” (U.S. EPA Office of Communications, Education, and Public Affairs; December 1997).

Regional Water Quality Control Board (RWQCB):

The RWQCB means any California RWQCB for a region as specified in Section 13200 of the California Water Code. There are nine RWQCBs that serve under the **SWRCB**. These nine RWQCBs are located in California and are responsible for enforcing water quality standards within their boundaries. A map of these boundaries is located in Section 3, Figure 3-1.

- In protecting water quality, each RWQCB:
- Adopts a region-specific Water Quality Control Plan or Basin Plan that contains water quality standards specific to the region's waters;
- Issues waste discharge requirements (WDRs) and water quality monitoring and reporting programs that implement the SWRCB's statewide policy and regulations along with the region-specific water quality standards specified in its Basin Plan; and
- Implements enforceable orders against violations of statewide and region-specific requirement

Replaced Impervious Surface (RIS):

Replaced **impervious surface** includes any activity that removes impervious materials and exposes the underlying soil or pervious subgrade during construction. Subtract **RIS** that drains to an existing **Treatment BMP** that will be protected and perpetuated (Table 4-1).

Resident Engineer (RE):

The RE administers the construction contract, makes decisions regarding acceptability of material furnished and work performed, and exercises contractual authority to direct the contractor. The RE may impose sanctions if the contractor fails to follow the appropriate actions specified in the contract to correct deficiencies.

Routine Maintenance:

Routine maintenance activities are intended to maintain the original line and grade, hydraulic capacity, or original purpose of a facility. **CGP** coverage does not apply to projects that are considered routine maintenance. Projects categorized as routine maintenance typically include landscape and highway planting, pavement overlay, and other projects with little or no new impervious surface or mass grading. Projects with extensive earthwork or where the replacement of existing roadway surfaces expose the underlying soil or pervious subgrade are not considered routine maintenance projects.

Runoff:

Runoff is comprised of surface waters that exceed the soil's infiltration rate and depression storage. It includes that portion of precipitation that appears as flow in streams, and also includes drainage or flood discharges that leave an area as surface flow or as pipeline flow, having reached a channel or pipeline by either surface or subsurface routes.

Slope/Soil Stabilization:

Soil stabilization is described as vegetation, such as grasses and wildflowers, and other materials, such as straw, fiber, stabilizing emulsion, protective blankets, etc. Soil stabilization is placed to stabilize areas disturbed by grading operations, to reduce loss of soil due to the action of water or wind, and to prevent water pollution.

Soil Modification:

Soil modification is the changing of characteristics to achieve an engineering design result. Historically, soil modification was performed to facilitate compaction, reduce infiltration, and increase the bearing capacity of the soil. Conversely, the physical and chemical properties of soil may be altered to increase infiltration and enhance vegetation establishment. Soil may be modified by incorporating inert and organic amendments. The most common of these amendments are sand and compost, respectively. Additional modifications include relieving of compaction through tilling and the addition of fertilizers to adjust pH, nitrogen, phosphorus, potassium, and trace nutrients.

Source Controls:

Source controls are control measures used on disturbed areas to reduce the introduction of sediment or other **pollutants** into stormwater **runoff**. Source controls prevent or limit the exposure of materials to stormwater at the source of those materials.



Sustainable Stormwater BMPs

- Sustainability is often described using the “triple bottom line” concept, which includes giving consideration to three primary principles: Social, Environmental, and Economic. The goal of sustainability is the satisfaction of basic social and economic needs, both present and future, and the responsible use of natural resources, all while maintaining or improving the well-being of the environment on which life depends (FHWA). A sustainable approach to highways means helping designers make balanced choices among environmental, economic, and social values—the triple bottom line of sustainability—that will benefit current and future road users.
- Sustainable stormwater BMPs are those that balance priorities of infiltration, water quality, safety, life cycle costs, and maintaining transportation. The SWRCB considers LID BMPs to be sustainable for water resources, stormwater is treated as a resource by improving water supply and improving water quality (SWRCB 2005).

Standard Urban Stormwater Mitigation Plan (SUSMP):

SUSMPs are special local requirements that designate **BMPs** that must be used for specific categories of development projects. PEs should contact the District/Regional **NPDES** Coordinator to see if an SUSMP is applicable for projects in urban areas.

State Water Resources Control Board (SWRCB):

As delegated by the **EPA**, the SWRCB is a California agency that implements and enforces the **CWA** Section 401 (p) **NPDES** permit requirements, and is the issuer and administrator of the **Caltrans Permit**. The SWRCBs mission is to preserve, enhance and restore the quality of California’s water resources, and ensure their proper allocation and efficient use for the benefit of present and future generations.

Stormwater Advisory Teams (SWAT):

Caltrans has established four Department-wide SWATs to evaluate new or modified **BMPs** and to develop procedures and guidance for implementing the **SWMP**:

- The Maintenance SWAT (M-SWAT) is composed of District Maintenance Stormwater Coordinators and representatives from each of the affected HQ Divisions. The M-SWAT provides any necessary review and/or evaluation of proposed and existing BMPs used by the Division of Maintenance. In addition, the M-SWAT reviews and assists in the development of training classes and guidance documents for implementing stormwater activities described in the **SWMP** for maintaining highways, bridges, facilities, and other appurtenances related to transport.
- The Project Design SWAT (PD-SWAT) is composed of District/Regional Design Stormwater Coordinators and related functional units and representatives from each of the affected HQ Divisions. The PD-SWAT provides review of proposed and existing BMPs utilized in the planning and design of projects. BMPs include Construction Site BMPs, Design Pollution Prevention BMPs, and **Treatment BMPs**. In addition, the PD-SWAT reviews and assists in the development of training classes and guidance documents for implementing stormwater activities relevant to project design.



- The Construction SWAT (C-SWAT) is composed of District Construction Stormwater Coordinators, District Permit Coordinators, and representatives from each of the affected HQ Divisions. The C-SWAT provides review of proposed and existing Construction Site BMPs and measures used for stabilization of soils. The C-SWAT also reviews existing procedures to ensure that they integrate the appropriate stormwater BMPs into the requirements of encroachment permits. In addition, the C-SWAT reviews and assists in the development of training classes and guidance documents for implementing stormwater activities relevant to construction activities and for issuing and administering encroachment permits.
- The Water Quality SWAT (WQ-SWAT) is composed of the District/Regional **NPDES** Coordinators and representatives from each of the affected HQ Divisions. The WQ-SWAT provides review of proposed and existing **Treatment BMPs**, and prioritizes research or studies of **Treatment BMPs**. The WQ-SWAT is a forum for discussing stormwater coordination activities underway or planned with other municipalities, reviewing and recommending public education efforts, sharing technical information, providing advice on compliance issues, and resolving issues of dispute on stormwater. Many of these activities result in recommendations for changes to the **SWMP** or policies and other documents on stormwater. The WQ-SWAT discusses stormwater budget allocations for the districts and HQ Divisions. The WQ-SWAT reviews data and findings from compliance-monitoring and evaluation activities, and recommends changes in practices to improve compliance efforts.

Stormwater Data Report (SWDR):

The SWDR is a document prepared by the PE that summarizes stormwater design information associated with a project. It is used to document stormwater related decisions for the purposes of assuring compliance throughout all phases of project delivery. It contains pertinent information related to BMP planning, design and estimating and helps to ensure functional unit collaboration. A SWDR is prepared and signed for all projects at every phase of project development. A PS&E phase SWDR is to be signed and stamped by the PE.

Stormwater Management Plan (SWMP):

The SWMP is the Caltrans policy document that describes how Caltrans conducts its stormwater management activities (i.e., procedures and practices). The SWMP provides descriptions of each of the major management program elements, discusses the processes used to evaluate and select appropriate **BMPs**, and presents key implementation responsibilities and schedules.

Stormwater Pollution Prevention Plan (SWPPP):

The Construction **General Permit** requires all construction projects that result in a **DSA** of at least one acre to develop and implement an effective SWPPP. The SWPPP is a plan that includes site map(s), an identification of construction/contractor activities that could cause pollutants in stormwater, and a description of measures or practices to control these **pollutants**. A **RWQCB** may require a SWPPP for projects which do not meet the **DSA** acreage requirements based upon water quality concerns.

Targeted Design Constituent (TDC):

A TDC is a pollutant that has been identified during Departmental runoff characterization studies to be discharging with a load or concentration that commonly exceeds allowable standards and which is considered treatable by currently available Department-approved **Treatment BMPs**.

Total Dissolved Solids (TDS):

TDS refers to the sum of all cations or anions (sometimes measured in parts per million as calcium carbonate). TDS comprise inorganic salts (principally calcium, magnesium, potassium, sodium, bicarbonates, chlorides and sulfates) and small amounts of organic matter that are dissolved in water.

In fresh water the total dissolved solids concentration typically ranges from 20 to 1,000 mg/l; in seawater, it ranges from 30,000 to 35,000 mg/l. High levels of dissolved solids concentrations can adversely affect drinking water quality.

Total Maximum Daily Load (TMDL):

TMDLs are pollutant load allocations for all point sources and nonpoint sources, and are intended to achieve a pollutant reduction goal along with a safety factor. TMDLs are developed in response to identification of **pollutants** as impairing a specific body of water identified in the 303(d) list.

Total Suspended Solids (TSS):

TSS is the mass of particles that are suspended in water. Suspended solids in water reduce light penetration in the water column, can clog the gills of fish and invertebrates, and are often associated with toxic contaminants because organics and metals tend to bind to particles.

Total Area to be Treated:

The total area to be treated is the entire area that is treated by the project, including both **pervious surfaces** and **impervious surfaces**. This includes the **NIS, ATA, and TMDL:CU**.

United States Environmental Protection Agency (EPA):

The EPA (<http://www.epa.gov/>) provides leadership in the nation's environmental science, research, education, and assessment efforts. The EPA works closely with other federal agencies, state and local governments, and Indian tribes to develop and enforce regulations under existing environmental laws. The EPA is responsible for researching and setting national standards for a variety of environmental programs and delegates to states and tribes responsible for issuing permits, and monitoring and enforcing compliance. The EPA issued regulations to control pollutants in stormwater **runoff discharges**, such as the **CWA**. (The CWA and **NPDES** permit requirement.)

Waste Discharge Requirement (WDR):

A WDR is a set of conditions issued by a **RWQCB** for a specific activity. The conditions may include numeric effluent criteria, monitoring requirements, reporting requirements, and other narrative criteria for discharge. WDRs may be required for any non-exempt non-stormwater **discharge**.

Waste Load Allocations (WLA):

A WLA represents the maximum load of **pollutants** each discharger of waste is allowed to release into a particular waterway for which a **TMDL** has been established. **Discharge** limits are usually required for each specific water quality criterion being, or expected to be, violated for that particular **water body**.

Water Body:

Water bodies refer to the waters of the United States. These include (a) All waters, which are currently used, were used in the past, or may be susceptible to use in interstate or foreign commerce, including all waters which are subject to the ebb and flow of the tide; (b) All interstate waters, including interstate wetlands; (c) All other waters such as intrastate lakes, rivers, streams (including intermittent streams), mudflats, sandflats, wetlands, sloughs, prairie potholes, wet meadows, playa lakes, or natural ponds, the use, degradation, or destruction of which would affect or could affect interstate or foreign commerce including any such waters: (1) which are or could be used by interstate or foreign travelers for recreational or other purposes; (2) from which fish or shellfish are or could be taken and sold in interstate or foreign commerce; or (3) which are used or could be used for industrial purposes by industries in interstate commerce; (d) All impoundments of waters identified in paragraphs (a) through (d) of this definition; (f) The territorial sea; and (g) Wetlands adjacent to waters (other than waters that are themselves wetlands) identified in paragraphs (a) through (f) of this definition.

Water Pollution Control Program (WPCP):

A WPCP is a plan to identify water quality management practices to be implemented that must be prepared for all construction projects that do not require preparation of a **SWPPP**. For Caltrans projects disturbing more than one acre, a SWPPP satisfies the requirement for a WPCP.

Water Quality Assessment Guidelines (WQAG):

The Water Quality Assessment Guidelines (WQAG) provide direction on format, content, and methods for preparing detailed Water Quality Assessment Reports (WQARs) and more summary Water Quality Assessment Memoranda.

Water Quality Assessment Report (WQAR):

The primary purpose of the Water Quality Assessment Report (WQAR) is to fulfill the requirements of the National Environmental Policy Act (NEPA) and the California Environmental Quality Act (CEQA), and to provide information, to the extent possible, for the **NPDES** permitting. It identifies potential water quality impacts/benefits associated with the proposed project, and recommends avoidance and/or minimization measures for potentially adverse impacts. Information from the WQAR is used in the PEAR.

Water Quality Flow (WQF):

The WQF is the numeric sizing criteria used for flow-based treatment devices. Caltrans has cooperatively developed rainfall intensity values with the RWQCBs and the **SWRCB** that are used in the Rational Formula to calculate the WQF; see Section 5.

Water Quality Volume (WQV):

The depth from the 85th percentile, 24-hour storm event multiplied by the **CDA** and volumetric runoff coefficient to determine the WQV.

Work Breakdown Structure (WBS):

The WBS is a product-oriented grouping of project elements that organizes and defines the total scope of the project. Each descending level represents an increasingly detailed definition of a project component. Project components may be products or services. The WBS defines the work elements, not the staff or resources that will perform the work.

THIS PAGE INTENTIONALLY LEFT BLANK.